

FRAMELESS GLASS

Extrusions & Components CH. 1

This section includes all the technical dimensions and purpose of each Rail, Post, Baseplate, End cap, Connections, Blank, Wallplate, Bracket and Hardware, Gasket/Wedge and Block profiles.

Style Specification CH. 2

Each Frameless Glass Style and the applicable components when assembled have varying span widths allowed in accordance with code requirements. This combination can be determined in this section.

Fixing Specification CH. 3

Compared to the Style Specification of each style, Fixing Specifications determine the span allowed in various wind zones with alternate methods of installation to common industry substrates.

Assembly Specifications CH. 4

Exploded cross-sectional views of each Frameless Glass style with the most common rail types. These diagrams show how each Extrusion & Component securely connect and insert to form a UNEX system.

Fabrication & Installation CH. 5

Once the maximum allowable span and assembly of a system is determined, then this section guides installers on how to fabricate each style in this manual including Vertical Dimensions and site measurement.



CONTENTS

CONTENTS



THE BENEFITS OF FRAMELESS GLASS

COMPLIANCE

Specifically engineered to comply with the extremely heavy Liveload classes A, B, E, & C3 of the NZ Building Code AS/NZS 1170.1:2002.

PRE-ENGINEERED SOLUTIONS

Full specifications available, saving cost and time designing a one-off balustrade.

AESTHETIC APPEAL

Concealed assembly fasteners, no protruding glazing-lugs, simple clean lines, tidy joints and glazing edges with No welds.

LOW MAINTENANCE

Aluminium channels do not rust, combined with high performance powdercoat or anodized finishes make it easy to clean.

FULL BACK UP

Support from NZ's leading balustrade specialists. In-house engineering expertise provides site-specific solutions.

UNEX
ARCHITECTURAL BARRIERS

DIRECT ORDERS OR ENQUIRIES TO:

PHONE: 0800 333 777

EMAIL: orders@unex.co.nz

www.unex.co.nz

NOTES, DISCLAIMERS AND EXCLUSIONS OF LIABILITY

1. The purpose of this manual is to provide balustrade fabricators, assemblers, specifiers, builders and installers ("The User"), the information they require for using the product for its intended purpose and within its structural and legal limitations.
2. This manual is to remain in the possession of the receiver, as intended by UNEX Systems at the time of issue. It is not to be copied, nor passed on to others other than for the purpose stated above. This manual remains the property of UNEX Systems and must be returned to UNEX Systems when no longer required or on the written request of UNEX Systems.
3. UNEX Systems must be notified of any change in the name, address or contact details of the person or company to whom this manual was issued.
4. It is the User's responsibility to ensure that the manual includes any amendments that have been issued by UNEX Systems.
5. The information contained in this manual has been compiled for New Zealand only, and must not be relied on in any other country.
6. Specialist advice must be sought from qualified sources for any information or requirement not specifically covered in this manual.
7. Any request for specific structural design requirements outside the scope of this manual must be made in writing to UNEX Systems and include all relevant information such as substrate details, proposed fixing methods, design wind speeds, etc.
8. This manual must only be used in conjunction and compliance with all other current applicable building standards or requirements.
9. Where any specifications, requirements or information set out in this manual conflict with, or are no longer compliant with, any applicable building standards or requirement, the User of the manual must notify UNEX Systems in writing so that the appropriate specifications, requirements, or information can be provided. Without limiting paragraphs 10 to 12, UNEX Systems will not be liable for any claims if this procedure is not followed.
10. All representations or warranties (statutory, express or implied), except any which may not be lawfully excluded, are expressly excluded including, without limitation, the implied warranties of merchantability and fitness for a particular purpose.
11. To the maximum extent permitted by law, the liability of UNEX Systems to any person for any loss whatsoever incurred arising directly or indirectly from the use of this manual, or by any error or omission in this manual, whether arising in contract, tort (including negligence), breach of statutory duty, or otherwise, is excluded.
12. If, despite paragraph 11, UNEX Systems is found liable, then to the maximum extent permitted by law, UNEX Systems will not be liable for any indirect or consequential loss suffered or incurred by the user.
13. The laws of New Zealand apply to these notes, disclaimers, and exclusion of liability.
14. Any reference to UNEX Systems in this document or manual is a reference to UNEX Systems (NZ) Limited, its successors or assigns.

SURFACE FINISHING

INTRODUCTION

One of the advantages of Aluminium as a material is that it provides an excellent substrate for surface finishing. Aluminium is therefore the preferred choice of material where coloured coatings are required. The main coating method used is "Powdercoating". Anodizing is also available but with a much more limited choice of colour. Care and Maintenance instructions for all finishes are given on Page 5. Warranties are available on extrusions for certain surface finish options. These are limited to those supplied by the supplier and/or applicator, and must be requested at the time of the order.

1. POWDERCOATING

Powdercoatings are applied as a powder, electrostatically charged to provide a uniform film thickness, followed by baking and final oven curing, resulting in a tough, smooth, and even coating. This process is performed in factory controlled conditions, and consistently gives a more uniform and superior finish compared to wet coating. Powdercoatings also have excellent adhesion to pretreated aluminium. The use of solvents for cleaning powdercoated surfaces should be strictly avoided.

2. ANODIZING

Anodizing is an induced thickening of the natural protective oxide film on the metal's surface, and not a coating in the usual sense. The resulting film is clear, hard, extremely corrosion resistant, and capable of being coloured. Colour options are however relatively limited, with Satin (Natural aluminium colour), Medium Bronze and Dark Bronze being the main colours economically available for balustrades. Some accessories, such as cast end caps, can not be anodized, and must be powdercoated in a coordinating colour. The depth of the anodized film can be varied to suit the application.

The use of abrasives for cleaning should be avoided as they can damage the anodic layer beyond repair.

CARE & MAINTENANCE OF UNEX BALUSTRADES

It is the Fabricators responsibility to ensure that a copy of these Care and Maintenance Instructions is made available to every purchaser of UNEX Balustrades. It is important that every building owner observes these recommendations to obtain the durability required in the NZ Building Code.

1. MAINTENANCE OF ALUMINIUM BALUSTRADES

Cleaning is necessary if the fine finish of powdercoated and anodized aluminium is to be preserved. Deterioration of the coating occurs mainly as a result of grime deposition and attack by contaminated moisture which in a coastal environment contains salt and sulphur compounds. Deposited grime and contaminations absorbs moisture like a sponge and holds it against the powdercoated and anodized surfaces. This permits attack to proceed thereby damaging the coating which cannot be restored.

- Safety barriers shall be maintained in a structurally sound condition and, where applicable, self-closing gates and other components required for the protection of children shall be kept operable. Defects should be remedied immediately once they are apparent.
- Ensure drainage holes in posts and rails are kept clear, on 6 months frequency.
- While surface finishes do not last forever, observance of these instructions will maintain their appearance and significantly extend their useful life.
- Powdercoated surfaces will lose some gloss with time. Where desired, powdercoated gloss may be enhanced with 'Dulux Gloss Up', used in accordance with the manufacturer's instructions.

CARE AND PROTECTION

Always protect the balustrades from contact with:

- Wet cement or plaster, household cleaners including bleach, paint splashes, chemicals, solvents, stains and fertilisers are possibly harmful to the surface finish. If contact does occur, remove the contaminant immediately and wash as described below.
- Copper, brass, lead, mild steel, CCA treated timber, cement or concrete less than 1 month old, and water which has contacted any of these substances.

GUIDELINES FOR ALUMINIUM BALUSTRADE CLEANING

It is recommended most residential balustrades in mild conditions or interior installations be cleaned at least every once a year. In areas where pollutants are common such as industrial or geothermal areas, and for all sites within 1 km from the sea or in any sea spray zone identified by Section 4.2 of NZS 3604:1999, cleaning must be carried out more frequently as required, but not less than every three months.

PROCEDURE FOR ALUMINIUM BALUSTRADE CLEANING

- a. Gently remove loose deposits with a wet sponge. Do not dry dust, or the surfaces will be scratched. Remove any moss growth, and ensure that all drain holes are unblocked, particularly those at the base of the posts and underside of lower rails.
- b. Using a soft brush and a mild household detergent in warm fresh water, clean the surface to remove any dust, salt, or other deposits. Pay particular attention to any areas not washed naturally by the rain. In the instance of stubborn stains, use ONLY Isopropyl alcohol (IPA) or methylated spirits to help remove these.
- c. Always rinse well after cleaning with fresh water so that the contact time of the cleaning solution is kept to a minimum. Hosing must be avoided under all circumstances. Rinse with a chamois, or a soft cloth.

CARE & MAINTENANCE OF UNEX BALUSTRADES - (CONT'D)

IMPORTANT NOTES

- Never use scrapers, emery paper, sandpaper, steel wool or other highly abrasive materials on any aluminium, nor acid or alkaline cleaners, or any chemical cleaners, as they can damage the anodised or powder coated finish.
- Be careful with emulsion cleaners as they too can attack anodised coatings – use only in consultation with companies who are specialists in anodised aluminium. Solvents, household cleaners, bleaches, and abrasive cleaners are possibly harmful to the surface finish and must not be used.
- All coated aluminium surfaces should avoid contact with acids, alkalis, mortar based products and solvents.
- Sunscreen can leave permanent marks on aluminium. Use gloves when handling, and, if affected, wash the sunscreen off immediately with warm, soapy water.

2. MAINTENANCE OF GLASS

Glass needs to be periodically washed to remove visible dirt and to prevent accumulations of dirt from bonding to or attacking the surface. Glass should be washed frequently as is needed to keep its appearance acceptable. In some locations, and for some building owners, this cleaning will be more frequent than for others.

GUIDELINES FOR GLASS CLEANING

- Glass should be cleaned using only cleaning materials which are free of grit and debris (to avoid scratching and marking of the glass surface).
- Only detergents and cleaning solutions which are recommended for cleaning glass should be used. Mild detergents are preferable.
- Extra care is necessary where high performance and coated glass products are installed as the coated surface can be susceptible to stains and scratches.
- Hand cleaning of the glass surface to visibly remove accumulated dust or fingerprints can be accomplished using a number of different glass cleaning products. Recommended cleaning product is Mr Muscle® Surface and Glass. For screen printed glass, use only neutral cleaning products on the printed surface. The use of ammonia-base and alcohol-base glass cleaners are not recommended because these products tend to leave visible streaks. The exterior surface of the glass is not coated so cleaning can be undertaken in the same fashion as ordinary glass.
- Glasses with a Low E or reflective coating need to be treated with special care when cleaning to ensure the coating is protected and not damaged once cleaned. Do not use razor blades, steel wool or other metallic objects on the coated surface.

PROCEDURE FOR GLASS CLEANING

- a) While cleaning ensure jewellery and watches are removed and gloves should be worn to avoid scratching the surface of the glass. scratches that occur from foreign objects will be permanent and are not repairable.
- b) Flood the glass surface with water and the spray-on cleaning solution or with a cloth saturated with the cleaning solution. Be generous with the amount of solution applied.
- c) Scrub the wetted surface with a clean, lint free towel or cloth.

(continued on following Page)

CARE & MAINTENANCE OF UNEX BALUSTRADES - (CONT'D)

- d) Wipe to dry with a clean, lint free towel or cloth. The use of a squeegee is not recommended and could increase the risk of damage to glass and as such should be avoided if possible.
- e) To prevent streaking, stop wiping when the glass is almost dry and there is a uniform residue of moisture left on the glass surface. The residue will quickly evaporate leaving a clean surface.
- f) Extra care is necessary where high performance and coated glass products are installed as the coated surface can be susceptible to stains and scratches.

IMPORTANT NOTES

- Do not use cleaners which contain Hydrofluoric or Phosphoric acid as they are corrosive to the glass surface.
- Avoid cleaning heat absorbing tinted glass in direct sunlight, as the glass will be excessively hot for optimum cleaning.
- Do not allow cleaning solutions to contact the edges of laminated glass, Insulating Glass Units or Mirrors.
- Do not store or place other material in contact with the glass. (This can damage the glass or create a heat trap leading to thermal breakage).
- Abrasive cleaners, powder-based cleaners, scouring pads or other harsh materials should not be used to clean windows or other glass products.
- Avoid causing extreme temperature changes to the glass as this may lead to thermal fracture of the glass, i.e. do not splash hot water on cold glass or freezing water on hot glass.
- Some tapes or adhesives can stain or damage glass surfaces. Avoid using such materials unless they are known to be easily removed.
- It is suggested that professional cleaners consult with their suppliers as to the suitability of available cleaning equipment, materials and methods before attempting to clean toughened glass.

3. MAINTENANCE OF STAINLESS STEEL

Stainless steels are highly corrosion resistant—however, stainless steel applications can still remain at risk to surface damage. Oxidation, corrosion, rusting, or staining can occur over the long-term in harsh environments without routine cleaning and maintenance. Repeat mechanical damage also contributes to a faster degradation of the metal.

All stainless steels contain at least 10.5% chromium by weight. It is this chromium content that creates a shield called the passive layer, which protects stainless steel from corrosion—unlike other steels. The higher the chromium content, the greater the corrosion resistance. Stainless steel rusting occurs when the passive layer is damaged and there is not enough chromium for it to reform.

GUIDELINES FOR STAINLESS STEEL CLEANING

Stainless steel must be cleaned regularly to preserve the metal's integrity and maintain a pristine appearance. With proper care, and by selecting an appropriate grade, stainless steel can be saved from corrosion. When stainless steel maintenance is neglected, corrosive substances can accumulate on vulnerable surfaces.

(continued on following Page)

CARE & MAINTENANCE OF UNEX BALUSTRADES - (CONT'D)

It is recommended most residential balustrades in mild conditions or interior installations be cleaned at least every 6 months. In areas where pollutants are common such as industrial or geothermal areas, and for all sites within 1 km from the sea or in any sea spray zone cleaning must be carried out more frequently as required, but not more than every three months.

PROCEDURE FOR STAINLESS STEEL CLEANING

- a) Use a soft nylon brush to remove accumulated dirt.
- b) Wash with warm water, mild soap or detergent.
- c) Follow with a clean-water rinse.
- d) Wipe dry with a soft cloth, disposable wipe, or air blower.

PROCEDURE FOR STUBBORN DIRT AND STAINS

- e) Use a soft nylon brush to remove accumulated dirt.
- f) Use non-scratching abrasion powders such as typical household cleaners.
- g) For more aggressive cleaning a small amount of vinegar can be added to the powder.
- h) These can be used with warm water, soft bristle brushes, sponges, or clean cloths.
- i) Follow with a clean-water rinse.
- j) Wipe dry with a soft cloth, disposable wipe, or air blower.

IMPORTANT NOTES

- Avoid any contact with carbon steels or iron.
- Use cleaners showing "Suitable for Stainless Steel"
- Do not weld, cut, drill, or grind carbon steel near stainless steel.
- Avoid contact with concrete detergents and chloride solutions.
- Do not use steel wool or other abrasive scrubbing pads.
- Never use chloride cleaners, abrasive cleaners, all-purpose cleaners, or chloride bleach cleaning products on stainless steel.

ABOUT THIS ADVICE

This information is offered as a general guide only and specific advice should always be sought from a reputable glazier or professional window cleaner before undertaking any cleaning. This guidance does not preclude the use of other methods, materials or equipment. However, the user should undertake careful evaluation and make suitable enquiries of the suitability of alternative methods, materials or equipment, before using them.

NZ BUILDING CODE COMPLIANCE

GENERAL

The New Zealand Building Code (NZBC) provides mandatory performance criteria for balustrades. The UNEX Balustrade system has been designed to make it easy for specifiers to ensure that balustrade compliance is achieved. The main building code clauses which affect balustrades are as below. Some areas of the code may not necessarily affect every balustrade application.

- B1: STRUCTURE - Structural strength and stability
- B2: DURABILITY - Durability requirements
- C2: MEANS OF ESCAPE - Fire Escape routes
- D1: ACCESS ROUTES – Handrails
- E2: WATER EGRESS – Water proofing
- F2: HAZARDOUS BUILDING MATERIALS - Glazed Balustrades
- F4: SAFETY FROM FALLING - Barrier Heights, Opening Sizes etc
- F9: RESTRICTING ACCESS TO RESIDENTIAL POOLS

The performance criteria contained in the Building Code stipulates what is to be achieved, without prescribing how it is to be achieved. For more specific guidance, the MBIE issues 'Approved Documents' which provide detailed methods of establishing NZBC compliance, in the form of 'Verification Methods' or 'Acceptable Solutions'. While other criteria may be acceptable, the onus is on the designer to demonstrate adequate compliance with the prime requirements of the NZ Building Code. A brief summary of the Building Code clauses relevant to balustrades and handrails, is found on the following pages. A Producer Statement is available on www.unex.co.nz.

Disclaimer: Note that the information provided on the Building Code and other regulations is provided in good faith, and as applicable at the time of writing. However it is provided on a 'no liability' basis, and as these documents are up-dated from time to time, the latest documents should be consulted for full information and checked for subsequent amendments.

**View The NZBC online at
www.building.govt.nz**

(continued on following Page)

CLAUSE B1 - STRUCTURES

Balustrades are required to be capable of resisting certain loads. These include 'Live Loads' such as may be induced by persons leaning on the balustrade. Live Loads vary with the application, eg:- Residential, Public etc. Balustrades with glass or other solid or semi-solid infill panels also need to withstand 'Wind Loads', which will vary with the location and other factors.

UNEX Balustrades have been designed to withstand the various human impact and wind loads as stipulated in the NZBC. This will be achieved if the balustrade heights and spacings between clamps or other fixing points do not exceed the maximum given for the particular balustrade style's specification and method of fixing as given in Chapters 2 and 3. The maximum post spacing should be determined from these chapters by the building designer and checked by the Fabricator. The building designer must also ensure that an appropriate design of the substrate to adequately resist the loads imposed by the balustrade for the particular spans and fixing methods chosen is included in the drawings and specifications.

HUMAN IMPACT LOADS

These vary with the designated use of the building they are situated in, and are detailed in the loading standards cited in B1/VM1 of the NZBC: AS/NZS 1170.1:2002 Structural Design Actions. For reference, the various loadings have been designated with a "Loading Class" in the UNEX specifications. When using Chapters 2 and 3, the Loading Class must firstly be selected from the table on the Page 175. Then the maximum clamp spacings can be determined for this class (along with the designated wind load if applicable), as indicated on the tables given in Chapters 2 and 3.

WIND LOADS

Balustrades with solid infill such as "glazed" styles must also withstand wind loads imposed, to the degree as stipulated in the NZBC. These loads are defined by the Design Wind Speed for the particular project (refer Chapter 2 Pages 48-49). This must be determined and the appropriate wind speed columns used in the tables in Chapters 2 & 3, to conclude the maximum clamp spacing.

(continued on following Page)

CLAUSE B2 - DURABILITY

The NZBC requires all balustrading to be sufficiently durable so as to remain functional for certain specified periods of time. These periods are given in the Acceptable Solution B2/AS1, which indicates a 'serviceable' durability requirement of 50 years for channels, points and top rails, and 15 years for infill members. Note that this durability requirement does not apply to non-serviceable aspects such as the surface finishes (eg. Powdercoating). For further information on these finishes refer to page 4.

The durability aspect of the UNEX balustrade system has been assessed by a Materials and Corrosion consultant. A brief summary of this report is that in their opinion, UNEX Balustrades will meet these requirements if the balustrades are fabricated, installed and maintained in accordance with UNEX Systems' recommendations, including specific requirements relating to durability as outlined on Pages 165-166. Note that this does not cover aesthetics, but only serviceability.

Certain Care and Maintenance procedures to be followed are given on Page 6.

(continued on following Page)

CLAUSE D1 - ACCESS ROUTES

Acceptable solution D1/AS1 stipulates requirements for handrails on all stairways, and on ramps steeper than 1:20 on "accessible" routes. The top rail on a balustrade may serve as a handrail on an access route providing it meets certain requirements including; the profile, a minimum distance perimeter of the top of the profile and the height of the top rail above the ramp or pitch line of the stairs is between 900 – 1000mm.

The VRE and CRR rails are the only rails that complies with the handrail profile requirements of D1/AS1 for "Private" and "Common" stairways, but not for "Accessible Stairways or Ramps", for which LRR & LRS rails are the only compliant rails.

Where a top rail of a balustrade on a stairway does not comply with D1/AS1, a compliant auxiliary LRR round side rail can be bracketed to the side of the glass infill panels.

D1/AS1 also limits the projection of a balustrade or handrail on an escape route including a stairway or ramp, so that it does not reduce the minimum width by more than 100mm. Particular attention should be given to the width of the stairs and ramps on escape routes to ensure there will be the minimum permitted width inside the balustrade(s) or handrail(s). This is particularly where balustrades are "top fixed". It is advisable to coordinate with the balustrade fabricator/installer early in the design process.

In some situations, balustrades may be required to be "imperforate and non-combustible". Whilst UNEX balustrades are not specifically designed to fulfill this requirement, they can usually be adapted to do so. UNEX Systems should be consulted if this is a requirement on any particular project.

UNEX Systems recommends that the NZBC is sighted in its entirety

(continued on following Page)

CLAUSE E2 - WATER EGRESS

Where the balustrade attachment to the substrate incorporates water-proofing considerations, clause E2 of the NZ Building Code should be observed. Figure 19 of the Acceptable Solutions (E2/AS1 dated 1 July 2005) shows a detail which could apply to a balustrade. To sight the full details, please refer direct to the original documents in E2/AS1. There are some key points to be noted in figure 19 which must be incorporated in any application;

- The balustrade is side-mounted to a vertical' surface (i.e. not top-mounted to a horizontal surface).
- The channel system is attached via a spacer which keeps the channel from directly bearing against the wall, and clears the drip edge above by a minimum of 25mm (Smaller clearances are usually accepted by Territorial Authorities).
- It shows a Neoprene or EPDM WASHER between the spacer and the cladding.
- It shows the fixing which anchors into the framing, going through a BATTEN in the cavity. It is important that any battens or packers used to transfer the compression loads within the cavity behind the cladding are vertical and extend over the full width and depth of the mounting points, bracket or spacer.
- It shows a layer of sealant between the fixing and the sides of the hole in the cladding through which the fixing passes.

(continued on following Page)

CLAUSE F2 - HAZARDOUS BUILDING MATERIALS

This clause has particular application to balustrades with glass infill panels, which are required by Acceptable Solution F2/AS1 to comply with NZS 4223. This requires that Grade A safety glazing material not less than 12mm thick be used. However in some situations the glass may need to be thicker than this 12mm minimum (and Grade A safety or with a SentryGlas interlayer) to meet this clause, refer to page 39.

Effective from 1st June 2016, structural glass barriers need to have an interlinking rail, unless the barrier is laminated safety glass and has features to retain panes of glass or prevent collapse, in the event of breakage. An interlinking rail must be designed to resist serviceability limit state (SLS) loads, specified in AS/NZS 1170 and B1/VM1, in the event that a glass pane of the barrier breaks.

It is the responsibility of the fabricator to ensure that the balustrade glazing design complies with NZS 4223 in all respects; including glass thickness, glass span, panel size, containment, etc; However the UNEX Balustrade System has been designed to make this easily achievable in most situations.

All glass used in UNEX Balustrades should be safety toughened.

CLAUSE F4 - SAFETY FROM FALLING

This clause stipulates when barriers such as balustrades are required, and provides generalized requirements for barriers such as: "Barriers shall be of appropriate height". Acceptable Solution F4/AS1 provides more specific information on barriers and pool fences, and covers such things as barrier heights, opening sizes, and restrictions on toeholds.

UNEX balustrades are entirely versatile, and can be fabricated in virtually any height or configuration. It is therefore, the responsibility of the fabricator to ensure that the finished product complies in all respects to the requirements of Clause F4, with reference to the intended use of the area as obtained from the specifier or owner.

UNEX Systems recommends that the NZBC is sighted in its entirety.

(continued on following Page)

CLAUSE F9 - RESTRICTING ACCESS TO RESIDENTIAL POOLS

This clause has the requirements to prevent unsupervised access by children under five years of age to residential pools. It requires barriers around pools to restrict unsupervised access by children. Barriers can include gates and suitably constructed doors. Some small heated pools may have a removable cover rather than a surrounding barrier.

F9/AS1 provides the Acceptable Solution for swimming pool barriers in general. F9/AS2 provides the Acceptable Solution for covers which may be used on above ground small heated pools.

CHAPTER 1 - FRAMELESS GLASS EXTRUSIONS & COMPONENTS

Rails	18-20
Channel Extrusions	21
Caps	22-24
Wallplates.....	25-26
Components	27
Gate Hardware.....	29
Clamps	31-32
Connectors & Jointers	33-35
Setting Blocks, Gaskets, & Wedges	36-37
Standoffs – Sets.....	38
Standoffs – Individual Components	39
Stainless Steel Rails - Components	40-42
Mini Posts - Components	43
Fasteners	44-45
Tools & Accessories.....	46

Extrusions &
Components

Style
Specifications

Fixing
Specifications

Assembly
Specifications

Fabrication &
Installation

RAILS

LRR

RAIL, ROUND, SIDE OUTER

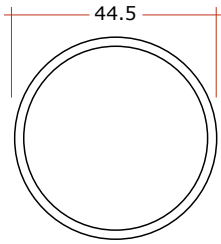

Form a continuous side rail when using LRWG bracket mounted to glass on UNEX's Frameless Styles.

Size complies with handrail requirements for an "Accessible Stairway or Ramp".

Note: Handrail bends available, contact UNEX

LRS

RAIL, ROUND RECESSED, TOP OUTER

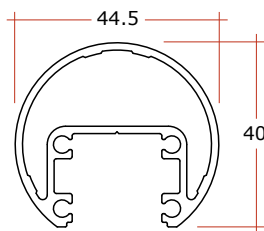

Forms a continuous side rail, or glazed top rail on UNEX's Frameless Styles.

Glazing Pocket Width = 19.6mm

Glazing Pocket Depth = 20.4mm

Refer to gasket table on page 30.

8 gauge screwpipes for wallplates, etc.

Recess accepts AIR2 clip infill.

Size complies with handrail requirements for an "Accessible Stairway or Ramp".

ARN

RAIL, TOP OUTER, HEAVY DUTY

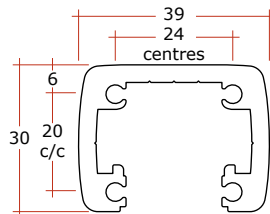

Push fit with the use of gaskets as per the gasket table on page 30, to form a continuous Top Rail. Accepts DIA, AIA & AIR2 inserts and the ANG range of spigots.

Glazing Pocket Width = 19.6mm

Glazing Pocket Depth = 26.4mm

8 gauge screwpipes.

CRR

RAIL, RECTANGLE, SIDE OUTER

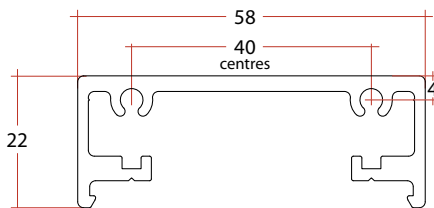

Clip fits to DRH, DRI2 or PZT Rails to form a continuous Side Rail when using the LBWG bracket mounted to glass in UNEX's Frameless Glass Balustrade styles.

8 gauge screwpipes for wallplates, etc.

Size complies with handrail requirements for a "Private & Common Stairway".

PRR

RAIL, RECTANGLE, TOP OUTER

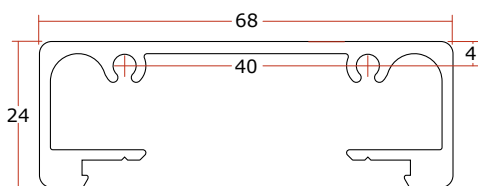

Clip fits to DRH or PZT Rails to form a continuous Top Rail.

8 gauge screwpipes for wallplates, etc.

RAILS (CONT'D)

VRT

RAIL, TOP OUTER

Clip fits to DRH or DZT3 Rails to form a continuous Top Rail. Accepts VNT spigot and VIT extrusion.

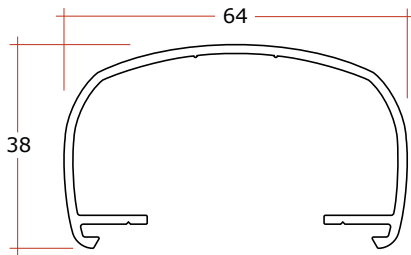

VRE

RAIL, ELLIPTICAL, TOP OUTER

Clip fits to DRH or PZT Rails to form a continuous Top Rail. 8 gauge screwpipes for wallplates, etc.

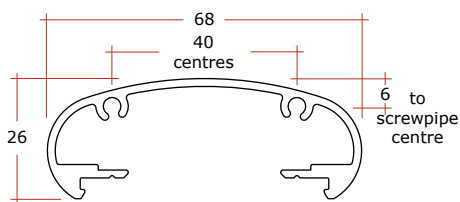

VRR

RAIL, RECTANGLE, TOP OUTER

Clip fits to DRH or PZT Rails to form a continuous Top Rail. 8 gauge screwpipes for wallplates, etc.

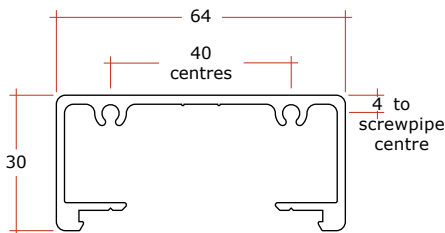

Q25

RAIL, SLIM STAINLESS STEEL, TOP OUTER

S/S316L Toprail, 25 x 21mm to suit 12mm glass. Accepts ASG25-12-29 polymer gasket for 12mm glass.

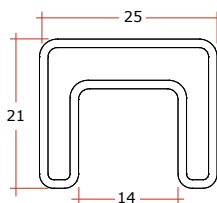

Q40

RAIL, STAINLESS STEEL, TOP OUTER

S/S316L Toprail, 40 x 30mm to suit 12mm - 17.5mm glass. Accepts ASG40 series rubber gasket for 12mm - 17.5mm glass

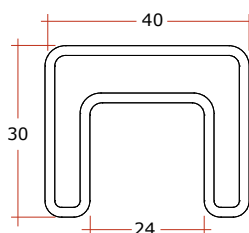

RAILS (CONT'D)

DRH

RAIL, TOP INNER

Clip fits to all Top Rails to form a continuous Top Rail with a flat underside (except with 19 x 1.0 recess as shown).

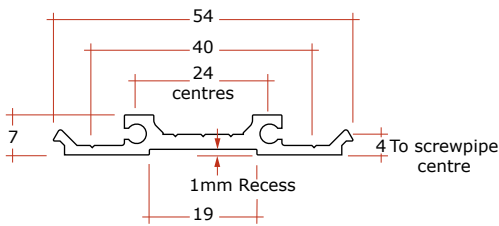

DZT3

HIGH-PROFILE GLAZING TOP INNER RAIL

Clip fits to VRT only to form a continuous Top Rail for Glass insertion.

Glazing Pocket Width = 19.6mm

Glazing Pocket Depth = 26.4mm

Refer to gasket table on page 30.

8 gauge screwpipes.

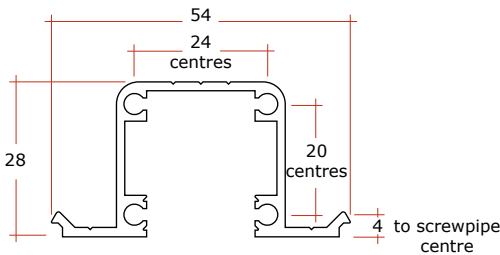

PZT

LOW PROFILE GLAZING TOP INNER RAIL

Clip fits to ART, PRR, VRE and VRR Rails to form a continuous Top Rail for Glass insertion.

Glazing Pocket Width = 19.6mm

Glazing Pocket Depth = 16.4mm

Refer to gasket table on page 30.

8 gauge screwpipes.

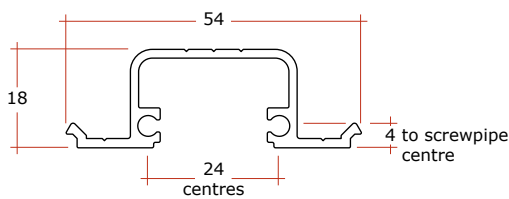

CRF

RAIL, SIDE INNER

Clip fits to CRR Rails to form a continuous Side Rail. 8 gauge screwpipes.

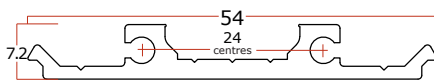

CHANNEL EXTRUSIONS

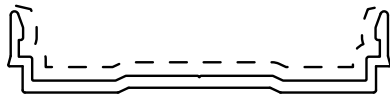

ABM-13R

ALIGNMENT CHANNEL, FOR AZM2® METROPOLIS SYSTEM

Bottom Channel for AZM2® top-fixed channel system. Pre-drilled to suit AGM-00-020X clamps. Refer to Style Specifications for exact centres.

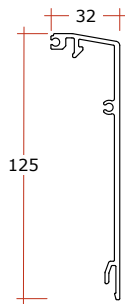
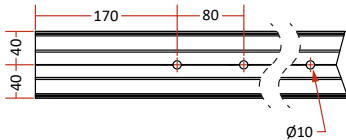

AVM-13

COVER FOR AZM2® METROPOLIS GLAZING CHANNEL

This cover is attached to both sides of the AZM2® glazing channel, by hooking over the AGM-00-020X series clamps, bearing plate, and bearing block, then clips to the ABM-13R bottom alignment channel.

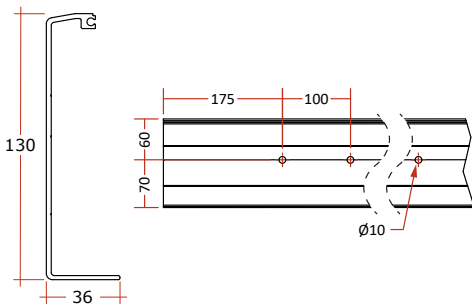

ABS150-13R

ALIGNMENT CHANNEL, BACK FOR AZS3® PANORAMA SYSTEM

Backing Channel for AZS3® side-fixed channel system. Pre-drilled to suit AGS-00-020X Clamps. Refer to Style Specifications for exact centres.

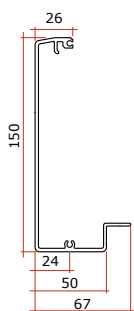

AVS150-13

COVER, FRONT FOR AZS3® PANORAMA SYSTEM

Front cover for AZS3® side-mounted channel that hooks over AGS-00-020X series clamps bearing plate, and attaches with FHT10-19 self drilling screws at 1m centres to the ABS150-13R channel. Accepts AIVS3 jointer insert.

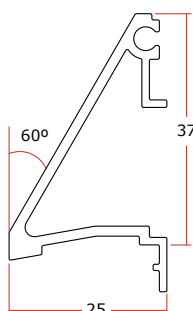

AVSB-13

ANTI-TOEHOLD BEAD, FOR AZS3® PANORAMA SYSTEM

Anti-toehold bead for AZS3® side-mounted channel that hooks to both alignment & front covers. Secure in place with the correct wedges as per table on page 30 and silicone if required.

CAPS

Extrusions & Components

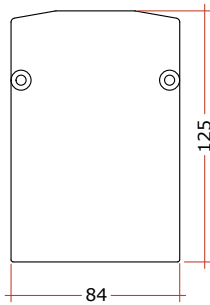

ACM-13

END CAP, FOR AZM2® METROPOLIS SYSTEM

3mm thick end cap which attaches to AZM2® top-fixed channel system. Universal attachment to be screwed on either end of the AZM2® channel, to the AVM-13 glazing covers. Commonly attached with 2 off FV8-19 screws.

Style Specifications

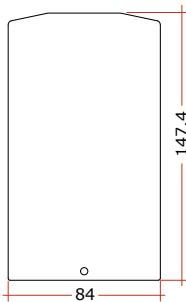

ACMV-13-32

END CAP, FOR AZM2® METROPOLIS SYSTEM, FOR STAIRS 0-32°

1.5mm thick end cap which attaches to AZM2® top-fixed channel system. Universal attachment to be screwed on either end of the AZM2® channel, to the AVM-13 glazing covers. Commonly attached with FV8-19 screws.

Fixing Specifications



ACSV-13-32

END CAP, FOR AZM2® METROPOLIS SYSTEM, FOR STAIRS 0-32°

1.5mm thick end cap which attaches to AZM2® top-fixed channel system. Universal attachment to be screwed on either end of the AZM2® channel, to the AVM-13 glazing covers. Commonly attached with FV8-19 screws.

Assembly Specifications

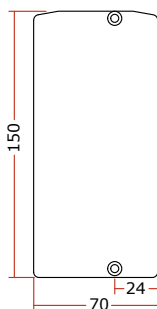

ACS-13

END CAP, AZS3® PANORAMA SYSTEM

3mm thick end cap which attaches to AZS3® side-fixed channel system. Universal attachment to be screwed on either end of the AZS3® channel, to the AVS150-13 front cover. Commonly attached with 2 off FV8-19 screws.

Fabrication & Installation

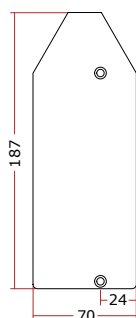

ACSB-13

END CAP, AZS3® PANORAMA SYSTEM, ANTI-TOEHOLD BEAD

3mm thick end cap. Screws to end of AVS150-13 cover when AVSB-13 anti-toehold bead is used, using FV8-19 screws. Cap can be screwed on both ends of the AZS3® side mounted channel system.

CAPS (CONT'D)

VCT

CAP, TOP RAIL

Cast aluminium Cap for VRT Top Rail ends.
Commonly attached with 1 off FS4-6 rivet.

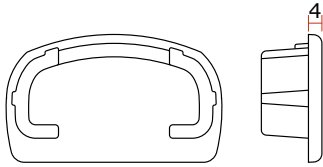

VRCT

CAP, TOP RAIL

Cast aluminium Cap for VRR Top Rail ends.
Commonly attached with 1 off FS4-6 rivet.

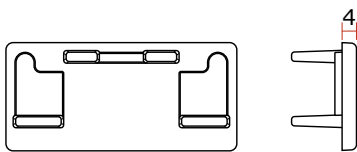

VECT

CAP, TOP RAIL

Cast aluminium Cap for VRE Top Rail ends.
Commonly attached with 1 off FS4-6 rivet.

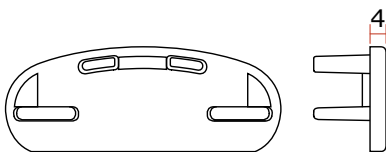

LCS

CAP, TOP RAIL

Cast aluminium cap for LRR & LRS Top Rail ends.
Commonly attached with 1 off FS4-6 rivet.

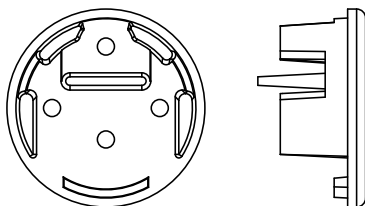

PRCT

CAP, TOP RAIL

Cast aluminium cap for PRR Top Rail ends.
Commonly attached with 1 off FS4-6 rivet.

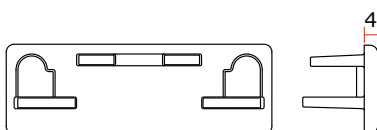

CAPS (CONT'D)

AAL

END CAP, FOR ARN TOP RAIL

3mm thick flat end cap. Screws to end of ARN Top Rail using FV8-19 screws.

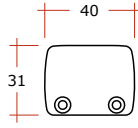

CRGG

CAP, SIDE RAIL

Cast aluminium cap for CRR Side Rail ends.

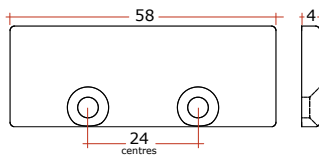

Extrusions & Components

Style Specifications

Fixing Specifications

Assembly Specifications

Fabrication & Installation

WALLPLATES

AWL

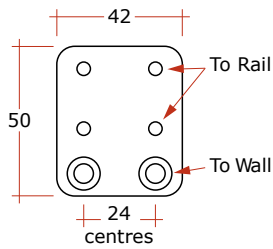

WALLPLATE, LOWER & MID RAILS

Flat wallplate, screws to ARN Lower Mid Rail ends using FV8-19, and then to adjacent wall or column (perpendicular applications only). Ø6.5mm holes to wall. 6mm thick plate.

PRWC

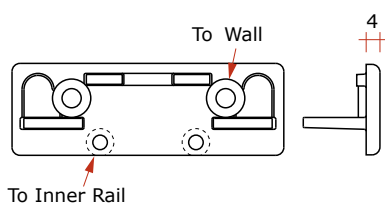

WALLPLATE, CAST, FOR PRR TOP RAIL

As PRCT, but drilled to be attached to the Inner Rail using FV8-19 and then to post face. PRR top rail then clips to Inner Rail, and slides up to PRWC (not suitable for rails between fixed ends).

PRWT

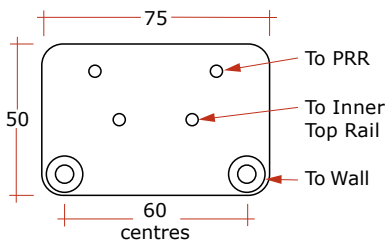

WALLPLATE, FOR PRR & VRE TOP RAILS

Flat wallplate, screws to end of PRR, VRE and Inner Rail using FV8-19, and then to wall or column (perpendicular applications only). Ø6.5mm holes to wall. 6mm thick plate.

VEWC

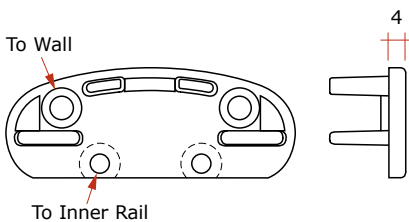

WALLPLATE, CAST, FOR VRE TOP RAIL

As VECT, but drilled to be attached to the Inner Rail using FV8-19, then to the post face. VRE rail then clips to Inner Rail, and slides up to VEWC (not suitable for rails between fixed ends).

CRWC

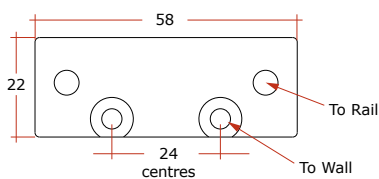

WALLPLATE, FOR CRR RAIL

Flat wallplate, screws to end of CRR Inner Rail using FV8-19, and then to wall or column (perpendicular applications only). 4mm thick plate.

WALLPLATES (CONT'D)

VNT

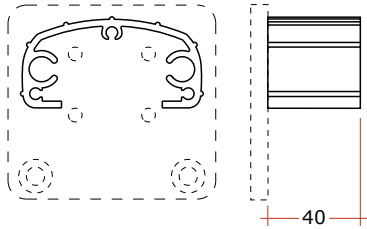

CONNECTOR FOR VWT WALLPLATE

Prefabricated from VIT extrusion. Is used to strengthen the connection between the VWT wall plate and the VRT Top Rail. Attach to VWT with 3x FV8-19 screws. Using this component is mandatory if the Top Inner Rail is either DRH, DRI2 or PZT.

VRWC

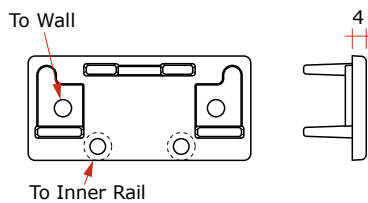

WALLPLATE, CAST, FOR VRR TOP RAIL

As VRCT, but drilled to be attached to the Inner Rail using FV8-19, then to the post face. VRR rail then clips to Inner Rail, and slides up to VRWC (not suitable for rails between fixed ends).

VRWT

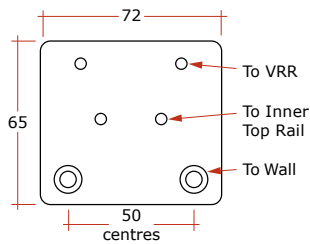

WALLPLATE, RECTANGLE VRR TOP RAIL

Flat wallplate, screws to end of VRR and Inner Rail using FV8-19, and then to wall or column (perpendicular applications only). Ø6.5mm holes to wall. 6mm thick plate.

VWC

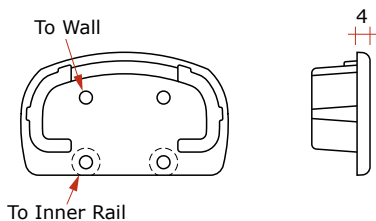

WALLPLATE, CAST, FOR VRT TOP RAIL

As VCT, but drilled to be attached to the Inner Rail using FV8-19, then to the post face. VRT rail then clips to Inner Rail, and slides up to VWC (not suitable for rails between fixed ends).

VWT

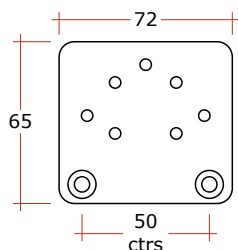

WALLPLATE, FOR TOP VRT RAIL

Flat wallplate, screws to end of Inner Rail, and to spigot (VNT) where applicable using FV8-19, and then to wall or column (perpendicular applications only). Ø6.5mm holes to wall. 6mm thick plate.

COMPONENTS

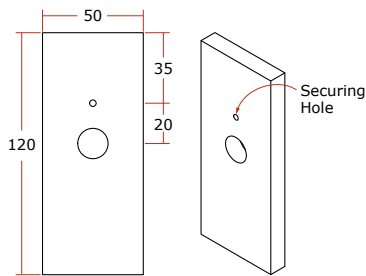

PK050-120BSV PACKER, FOR AZS3® PANORAMA SYSTEM

Aluminium packer for packing out and attaching AZS3® system to timber. Two packers per clamp required. Use with SG120-12 neoprene gasket cut to size to separate from substrate. Secure packers to ABS150-13R from inside of the cover with 1x FS4-4 through the smaller securing hole to prevent packer from rotating onsite. 10mm thick flat plate.

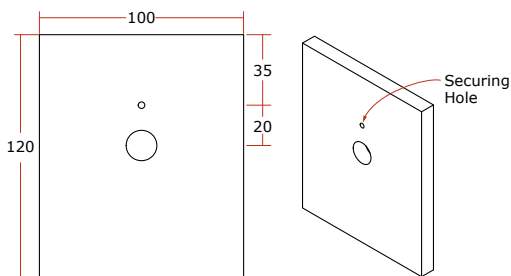

PK100-120BSY PACKER, FOR AZS3® PANORAMA SYSTEM

Aluminium packer for packing out and attaching AZS3® system to concrete. One packer per clamp required. Use with SG120-12 neoprene gasket cut to size to separate from substrate. Secure packers to ABS150-13R from inside of the cover with 1x FS4-4 through the smaller securing hole to prevent packer from rotating onsite. 10mm thick flat plate.

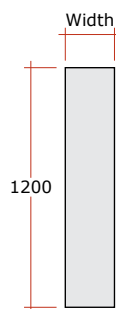

SG120-12

NEOPRENE GASKET

Gasket for side-fixed situations. Used to increase durability. Placed between packers and substrate. 1.5mm thick neoprene, with self-adhesive backing. No holes. 120mm width, and 1200mm long.

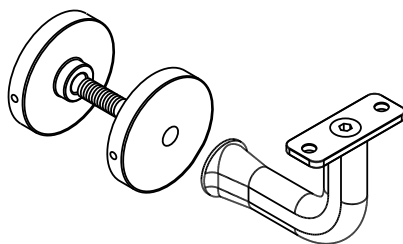

LBWG

HANDRAIL BRACKET, FLAT INNER RAIL

Stainless Steel bracket for mounting handrail to the side of glass. Ø30mm holes required in glass. This bracket requires a connection to the DRH inner rail and is commonly attached using 2x FV10-19TR.T1 screws.

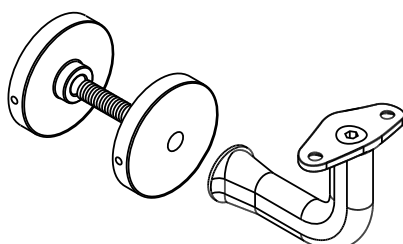

LRWG

HANDRAIL BRACKET, LRR ROUND RAIL

Stainless Steel bracket for mounting handrail to the side of glass. Ø30mm holes required in glass. This bracket connects directly to the LRR Rail and is commonly attached using 2x FV10-19TR.T1 screws.

GATE HARDWARE

Extrusions & Components

Style Specifications

Fixing Specifications

Assembly Specifications

Fabrication & Installation

GHGG4.XX

GLASS GATE HINGE, GLASS TO GLASS

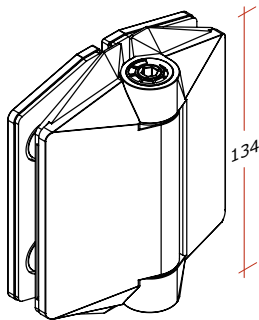

Stainless-Steel 2205 grade, self-closing safety hinge for glass gates. Soft-closing, single action, non-hold open, with a simple quick-adjust ratchet system. To be used with child proof safety latch. Anti-foot-hold gasket and safety cap included. Accepts 10mm or 12mm toughened glass infill. Glass gate in-line to balustrade. Maximum 900mm wide by 1500mm high, with a 45kg max weight, recommended width is 800mm wide. Requires cut-outs in glass as shown below.

Polaris 125 Series

Finish Options (Supplied in pairs):
 GHGG4.PF = Polish finish (default)
 GHGG4.SF = Satin finish
 GHGG4.BK = Black finish

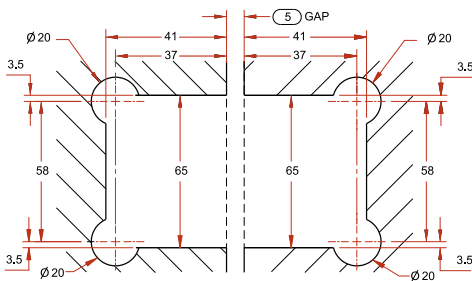
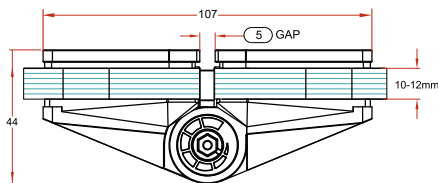

GHPG4.XX

GLASS GATE HINGE, POST TO GLASS

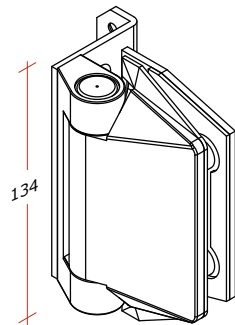

Stainless Steel 2205 grade, self-closing safety hinge for glass gates. Soft-closing, single action, non-hold open, with a simple quick-adjust ratchet system. To be used with child proof safety latch. Anti-foot-hold gasket and safety cap included. Accepts 10mm or 12mm toughened glass infill. Glass gate in-line to balustrade post. Maximum 900mm wide by 1500mm high, with a 45kg max weight, recommended width is 800mm wide. Requires cut-outs in glass as shown below.

Polaris 125 Series

Finish Options (Supplied in pairs):
 GHPG4.PF = Polish finish (default)
 GHPG4.SF = Satin finish
 GHPG4.BK = Black finish

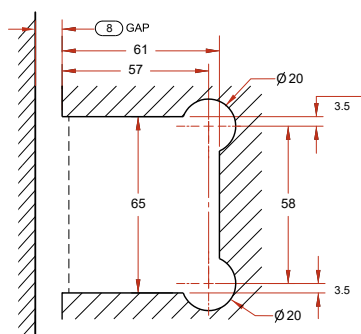
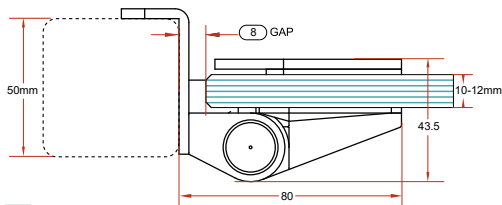

GATE HARDWARE (CONT'D)

GHWG4.XX

GLASS GATE HINGE, WALL TO GLASS

Stainless Steel 2205 grade, self-closing safety hinge for glass gates. Soft-closing, single action, non-hold open, with a simple quick-adjust ratchet system. To be used with child proof safety latch. Anti-foot-hold gasket and safety cap included. Accepts 10mm or 12mm toughened glass infill. Glass gate perpendicular to wall. Maximum 900mm wide with a 45kg max weight. Requires cut-outs in glass as shown below.

Polaris 125 Series

Finish Options (Supplied in pairs):
 GHWG4.PF = Polish finish (default)
 GHWG4.SF = Satin finish
 GHWG4.BK = Black finish

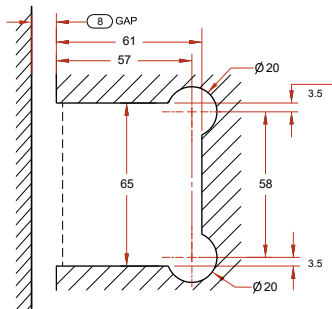
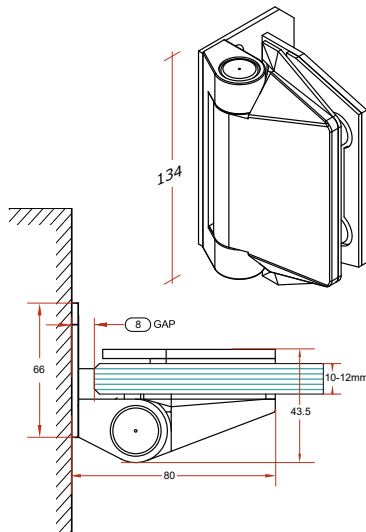

GLGG4.XX

GLASS GATE LATCH, GLASS TO GLASS

Stainless Steel 2205 grade. Self-engaging magnetic latch, for latching glass gate in-line to glass balustrade. No Stop required. Requires 2 x Ø12mm holes in glass gate panel, refer to diagram below.

Polaris 700 Series

Finish Options:
 GLGG4.PF = Polish finish (default)
 GLGG4.SF = Satin finish
 GLGG4.BK = Black finish

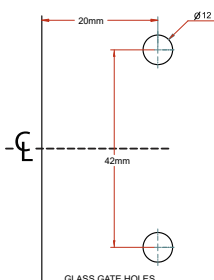
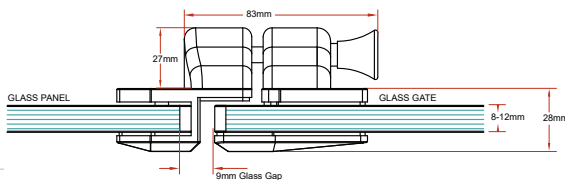
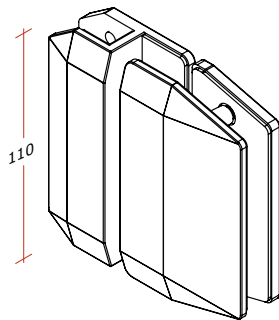

GATE HARDWARE (CONT'D)

GLGP4.XX

GLASS GATE LATCH, GLASS TO POST

Stainless Steel 2205 grade. Self-engaging magnetic latch for glass gates, for latching to posts. No Stop required. Requires 2 x Ø12mm holes in glass per latch, refer to diagram below. Fasteners as required 3 x M5 S/S (FM5-16A) fasteners to attach to Aluminium post. If glazing recess exists on post make clearance hole through AIA (insure AIA insert used) and fasten to post web, with suitable fasteners.

Finish Options:
 GLGP4.PF = Polish finish (default)
 GLGP4.SF = Satin finish
 GLGP4.BK = Black finish

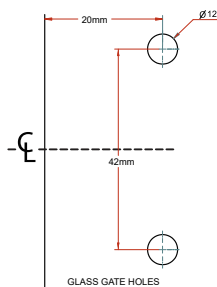
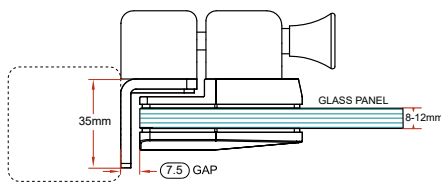
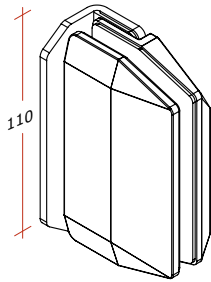

Extrusions & Components

Style Specifications

Fixing Specifications

Assembly Specifications

Fabrication & Installation

CLAMPS - KITSETS

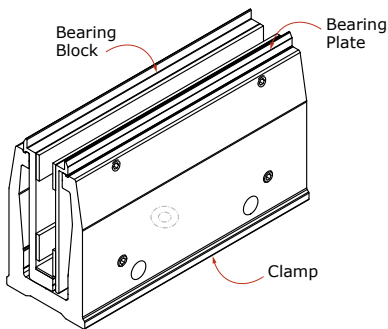

AGM-00-020C

CLAMP ASSEMBLY UNIT FOR AZM2® METROPOLIS SYSTEM

Clamp for the AZM2® system. Inserts into ABM-13R bottom alignment channel with **central fixing** to concrete, masonry or steel. Allows vertical adjustment of glass. Assembly made up of Clamp, Bearing Block, and Bearing Plate.
AGM-12-020C= accepts 12mm glass
AGM-13-020C= accepts 13.52mm glass
AGM-14-020C= accepts 14.28mm glass
AGM-15-020C= accepts 15mm glass

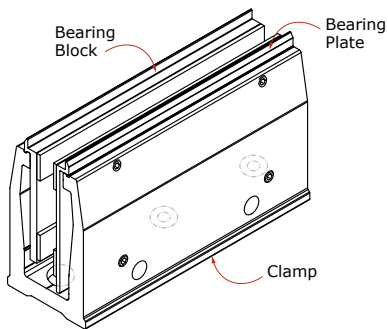

AGM-00-020T

CLAMP ASSEMBLY UNIT FOR AZM2® METROPOLIS SYSTEM

Clamp for the AZM2® system. Inserts into ABM-13R bottom alignment channel with **triple fixings** to timber. Allows vertical adjustment of glass. Assembly made up of Clamp, Bearing Block, and Bearing Plate.
AGM-12-020T= accepts 12mm glass
AGM-13-020T= accepts 13.52mm glass
AGM-14-020T= accepts 14.28mm glass
AGM-15-020T= accepts 15mm glass

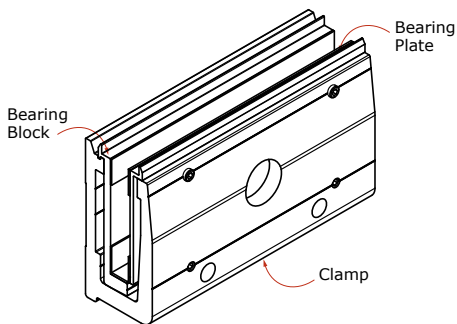

AGS-00-020C

CLAMP ASSEMBLY UNIT FOR AZS3® PANORAMA SYSTEM

Clamp for the AZS3® system. Inserts into ABS150-13R back alignment channel with **central fixing** to concrete, masonry or steel. Allows vertical adjustment of glass. Assembly made up of Clamp, Bearing Block, and Bearing Plate.
AGS-12-020C = accepts 12mm glass
AGS-13-020C = accepts 13.52mm glass
AGS-14-020C = accepts 14.28mm glass
AGS-15-020C = accepts 15mm glass
AGS-16-020C = accepts 16.28mm glass

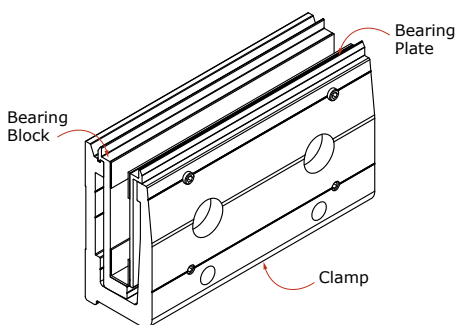

AGS-00-020D

CLAMP ASSEMBLY UNIT FOR AZS3® PANORAMA SYSTEM

Clamp for the AZS3® system. Inserts into ABS150-13R back alignment channel with **double fixings** to timber. Allows inward and outward vertical adjustment of glass. Assembly made up of Clamp, Bearing Block, and Bearing Plate.
AGS-12-020D = accepts 12mm glass
AGS-13-020D = accepts 13.52mm glass
AGS-14-020D = accepts 14.28mm glass
AGS-15-020D = accepts 15mm glass
AGS-16-020D = accepts 16.28mm glass

CLAMPS - INDIVIDUAL COMPONENTS

Extrusions & Components

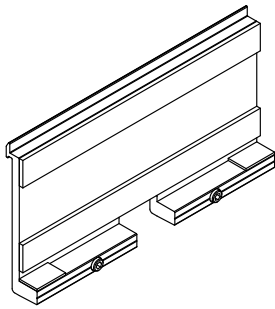

BEARING BLOCK, FOR AZM2® METROPOLIS SYSTEM

Bearing Block for AZM2® top-fixed channel systems. Pre-drilled with grub screws to suit **central fixing** AGM-00-020C clamps to concrete or steel. Refer to Style and Fixing Specifications for exact centres.

Refer to page 26 for complete clamp kits which includes this component.

Style Specifications

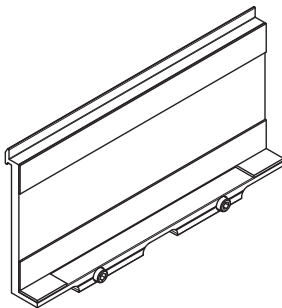

BEARING BLOCK, FOR AZM2® METROPOLIS SYSTEM

Bearing Block for AZM2® top-fixed channel systems. Pre-drilled with grub screws to suit **triple fixing** AGM-00-020T clamps to timber. Refer to Style and Fixing Specifications for exact centres.

Refer to page 26 for complete clamp kits which includes this component.

Fixing Specifications

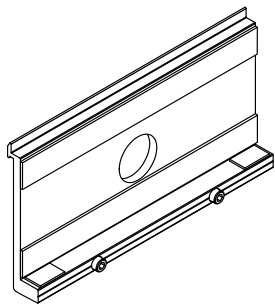

BEARING BLOCK, FOR AZS3® PANORAMA SYSTEM

Bearing Block for AZS3® side-fixed channel systems. Pre-drilled with grub screws to suit **central fixing** AGS-00-020C clamps to concrete or steel. Refer to Style and Fixing Specifications for exact centres.

Refer to page 26 for complete clamp kits which includes this component.

Assembly Specifications

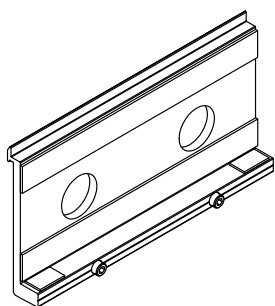

BEARING BLOCK, FOR AZS3® PANORAMA SYSTEM

Bearing Block for AZS3® side-fixed channel systems. Pre-drilled with grub screws to suit **double fixing** AGS-00-020D clamps to timber. Refer to Style and Fixing Specifications for exact centres.

Refer to page 26 for complete clamp kits which includes this component.

Fabrication & Installation

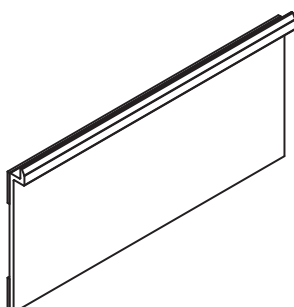

BEARING PLATE, FOR METROPOLIS AZM2® & AZS3® PANORAMA SYSTEM

Bearing Plate for AZM2® top-fixed channel & AZS3 side-fixed channel systems. Trimmed for clearance of grub screws on bearing blocks.

Refer to page 26 for complete clamp kits which includes this component.

CONNECTORS & JOINTERS

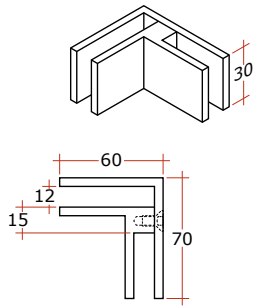

AGKC

GLASS SUPPORT BRACKET, 90° CORNER

Stainless Steel glass clamp designed to help align and enhance the strength of 90° corner glass frameless balustrade panels. Requires no holes in glass.

Accepts 12mm thick Toughened Glass.

Note: sizes may vary, check with UNEX

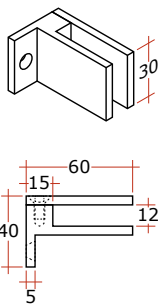

AGKE

GLASS SUPPORT BRACKET, GLASS TO WALL

Stainless Steel glass clamp designed to attach an end pane to the wall and therefore help align and enhance the strength of a frameless glass balustrade. Requires no holes in glass. Ø7mm holes to wall.

Accepts 12mm thick Toughened Glass.

Note: sizes may vary, check with UNEX

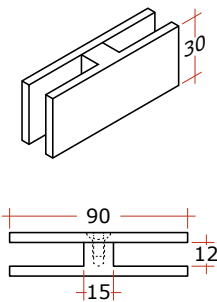

AGKI

GLASS SUPPORT BRACKET, IN-LINE

Stainless Steel glass clamp designed to help align and enhance the strength of in-line frameless glass balustrade panels. Requires no holes in glass.

Accepts 12mm thick Toughened Glass.

Note: sizes may vary, check with UNEX

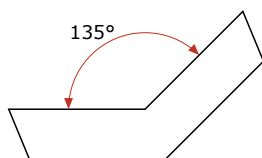

DNS135

SUSPENDED CORNER GUSSET

Attach to the top surface of two Top Inner Rails on a suspended corner mitre. Commonly attached to Inner Rail with 4 off FS5-4 rivets. 3mm thick flat plate.

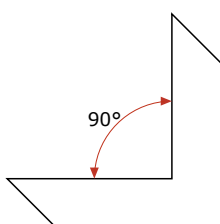

DNS90

SUSPENDED CORNER GUSSET

Attach to the top surface of two Top Inner Rails on a suspended corner mitre. Commonly attached to Inner Rail with 4 off FS5-4 rivets. 3mm thick flat plate.

CONNECTORS & JOINTERS (CONT'D)

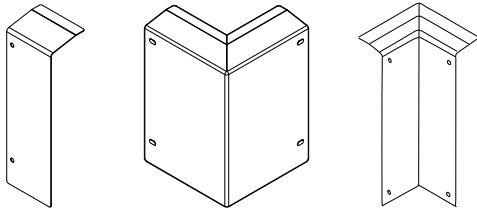

AFVM
AFVMH
AFVMI

JOINTER FLASHINGS - METROPOLIS

For AZM2® Metropolis front cover. Sits outside of the AVM front cover, powdercoated to suit.

AFVM = Inline
AFVMH = 90° external corner
AFVMI = 90° internal corner

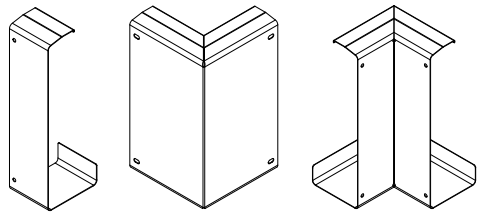

AFVS
AFVSH
AFVSI

JOINTER FLASHINGS - PANORAMA

For AZS3® Panorama front cover. Sits on outside of AVS150 front cover, powdercoated to suit.

AFVS = Inline
AFVSH = 90° external corner
AFVSI = 90° internal corner

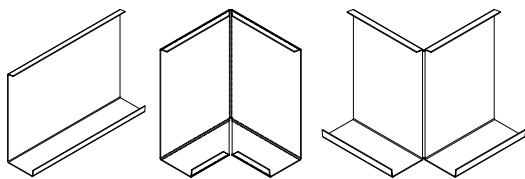

AIVS3-02
AIVSH3-90
AIVSI3-90

JOINTER - PANORAMA AVS150-13 FRONT COVER

A hidden internal insert used as, or to create jointers for the AVS150-13 Panorama front cover. May also be modified to use as a corner jointer. Commonly attached with FS4-4 rivets or adhesive.

AIVS3-02 = 200mm length for butt joints
AIVSH3-90 = 90° external corner
AIVSI3-90 = 90° internal corner

CONNECTORS & JOINTERS (CONT'D)

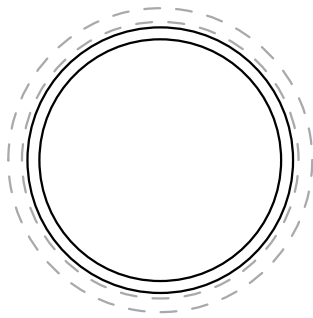

LJR
LJR-015

JOINTER, ROUND RAIL

An extrusions suitable for joining the recessed LRR Top Rail.

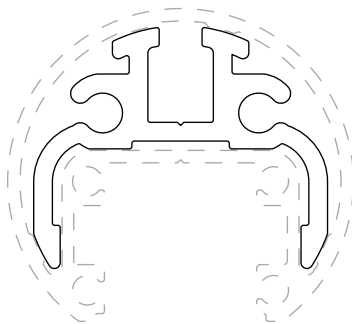

LJS
LJS-015
LJSH-90
LJSH-00

JOINTER, RECESSED ROUND RAIL

An extrusions suitable for joining the recessed LRS Top Rail. Also used for fabricating corner joins by welding or screwing together mitred pieces in the screwpipes.

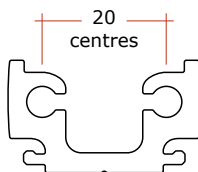

MANG

INSERT, SPIGOT FOR VRL2 RAIL

For manufacturing customised ANG type spigots. Inserts into ARN rail. May be used as a stiffener.

MANW

INSERT, SPIGOT FOR VRW RAIL

For manufacturing custom ANW type spigots, inserts into VRW Rail. May be used as a stiffener.

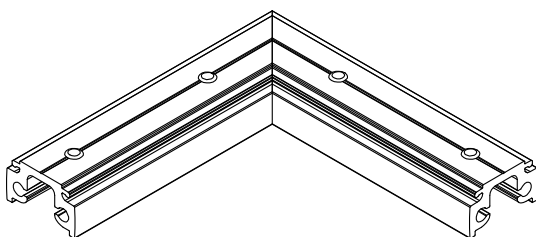

ANGH-90G
ANGH-00G
ANGV-00G

JOINTER, ARN TOP RAIL

A insert used as, or to create, jointers for the ARN Top Rail. May be ordered in custom horizontal or vertical angles. Commonly attached with grub screws (included), at fixed intervals along length of extrusion.

ANGH-90G = ~200mm length mitred to suit 90° corner

ANGH-XXG = mitred to suit custom horizontal angle corner

ANGV-XXG = mitred to suit custom vertical angle corner

SETTING BLOCKS, GASKETS, & WEDGES

Extrusions & Components

SBC

SETTING BLOCK

3 x 10 x 25mm, self adhesive backing.

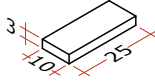

Style Specifications

SBG

SETTING BLOCK

5 x 9 x 25mm, self adhesive backing.

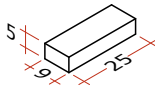

Fixing Specifications

SRG20-25 SRG20R

RETAINED BACK SEAL, YELLOW RETAINER

A TPE glazing gasket for the outer or inaccessible glass face. Engages the screwpipe in certain rails, by sliding in prior to assembly. For 8 gauge screwpipes only. Refer to table on page 30 for appropriate wedge to suit. SRG20-25 applies to purchasing in 25m lengths. SRG20R applies to purchasing 100m rolls.



Assembly Specifications

SRG30-25 SRG30R

RETAINED BACK SEAL, GREEN RETAINER

A TPE glazing gasket for the outer or inaccessible glass face. Engages the screwpipe in certain rails, by sliding in prior to assembly. For 8 gauge screwpipes only. Refer to table on page 30 for appropriate wedge to suit. SRG30-25 applies to purchasing in 25m lengths. SRG30R applies to purchasing 100m rolls.



Fabrication & Installation

SRG40-25 SRG40R

RETAINED BACK SEAL, CLEAR RETAINER

A TPE glazing gasket for the outer or inaccessible glass face. Engages the screwpipe in certain rails, by sliding in prior to assembly. For 8 gauge screwpipes only. Refer to table on page 30 for appropriate wedge to suit. SRG40-25 applies to purchasing in 25m lengths. SRG40R applies to purchasing 100m rolls.



***SRE retained gasket has been superseded by SRG40*

SETTING BLOCKS, GASKETS, & WEDGES (CONT'D)



SWE20-25
SWE20R

WEDGE, GREY STRIPE

TPE wedge gasket (with a grey stripe) for use with glass in conjunction with SRG gasket in glazing channels and all glazing recesses. Refer to table on this page for appropriate wedge to suit.
Compressed thickness = approx 2mm.
SWE20-25 applies to purchasing in 25m lengths.
SWE20R applies to purchasing 100m rolls.



SWE25-25
SWE25R

WEDGE, WHITE STRIPE

TPE wedge gasket (with a white stripe) for use with glass in conjunction with SRG gasket in glazing channels and all top rail glazing recesses. Refer to table on this page for appropriate wedge to suit.
Compressed thickness = approx 2.5mm.
SWE25-25 applies to purchasing in 25m lengths.
SWE25R applies to purchasing 100m rolls.

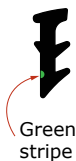

SWE30-25
SWE30R

WEDGE, GREEN STRIPE

TPE wedge gasket (with a green stripe) for use with glass in conjunction with SRG gasket in glazing channels and all top rail glazing recesses. Refer to table on this page for appropriate wedge to suit.
Compressed thickness = approx 3.0mm.
SWE30-25 applies to purchasing in 25m lengths.
SWE30R applies to purchasing 100m rolls.

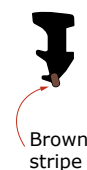

SWE35-25
SWE35R

WEDGE, BROWN STRIPE

TPE wedge gasket (with a brown stripe) for use with glass in conjunction with SRG gasket in glazing channels and all top rail glazing recesses. Refer to table on this page for appropriate wedge to suit.
Compressed thickness = approx 3.5mm.
SWE35-25 applies to purchasing in 25m lengths.
SWE35R applies to purchasing 100m rolls.

TYPICAL WEDGES FOR VARIOUS GLASS THICKNESSES

Glass Thickness (mm)	Retaining gasket	Colour	Wedge	Colour
10	SRG40	Clear	SWE55	Red
12	SRG40	Clear	SWE35	Brown
13.5	SRG30	Green	SWE30	Green
14.28	SRG30	Green	SWE25	White
15	SRG20	Yellow	SWE25	White
16.28	SRG20	Yellow	SWE20	Grey

STANDOFFS – SETS

Extrusions & Components

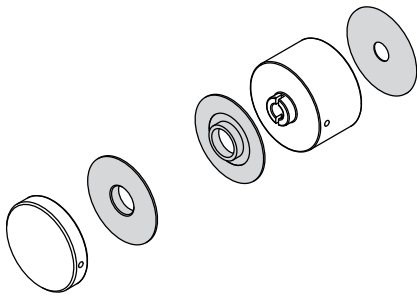

AOA050DS.XX

ALUMINIUM, 50MM DIA X 30MM SET, STD CAP

Aluminium Arena-Points standoff set, including 30mm spacer, standard cap, two FWPB49-16 bushes and a SGC49-10N gasket.

The two digits in the suffix denote the following surface finish options;

AOA050DS.NA	25 Mu Natural Anodised
AOA050DS.BK	Powdercoated Matt Black
AOA050DS.P1	Powdercoated to suit

Style Specifications

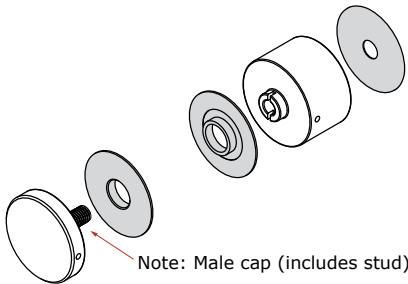

AOA050DT.XX

ALUMINIUM, 50MM DIA X 30MM SET, MALE THREAD CAP

Aluminium standoff set, including 30mm spacer, cap with male thread, two FWPB49-16 bushes and a SGC49-10N gasket. The two digits in the suffix denote the following surface finish options;

AOA050DT.NA	25 Mu Natural Anodised
AOA050DT.BK	Powdercoated Matt Black
AOA050DT.P1	Powdercoated to suit

Fixing Specifications

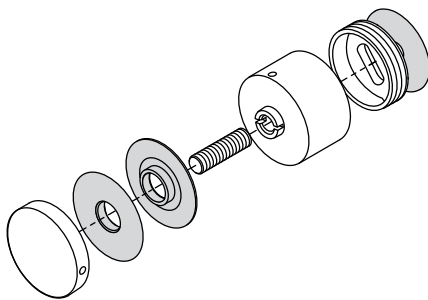

AJS050DT.XX

ADJUSTABLE ARENA-POINTS, 50MM DIA X 30MM SET, MALE THREAD CAP

Stainless steel grade 2205 Duplex Arena-Points standoff set, including 30mm spacer, cap with male thread, two bushes and a gasket.

The two digits in the suffix denote the following surface finish options;

AJS050DT.P1	Powdercoated
AJS050DT.BK	Black
AJS050DT.PF	Mirror polished finish
AJS050DT.SF	Satin polished finish (Satin finish is only recommended for interior use)

Assembly Specifications

Fabrication & Installation

STANDOFFS – INDIVIDUAL COMPONENTS

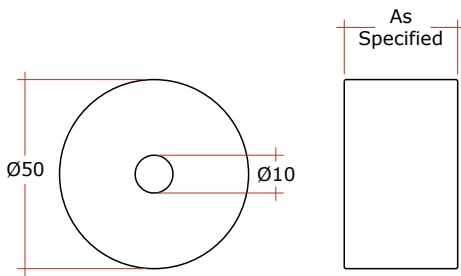

AOA050VB
AOA050WB
AOA050XB
AOA050YB
AOA050LB

SPACERS, CUT TO SIZE

50mm diameter unthreaded aluminium spacers. Supplied cut to your specified thickness (up to a maximum of 100mm). Surface finished items are made to order.

- AOA050VB = 3-10mm spacers
- AOA050WB = 11-30mm spacers
- AOA050XB = 31-48mm spacers
- AOA050YB = 49-99mm spacers
- AOA050LB = 100mm spacers

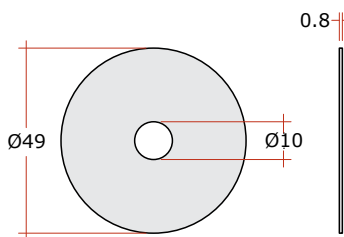

SGC41-10N
SGC49-10N

GASKET 49MM OD X 10MM ID

Neoprene gasket, 0.8mm thickness. Used between the surfaces of the spacer and the substrate to assist with preventing water ingress, and to separate materials that may detrimentally react. The use of this gasket is particularly important with aluminium spacers.

- SGC41-10N = Gasket for AJS050
- SGC49-10N = 49mm OD x 10mm ID

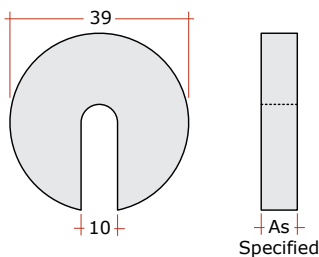

FWPS39-10XXX SPACER, SLOTTED

UV stabilized Black polymer slotted spacers which are 39mm OD with a 10mm wide slot. They are available in 1mm, 3mm, 5mm, and 10mm thicknesses.

The last X digit denotes the following thicknesses;

- FWPS39-10x1 = 1mm thick
- FWPS39-10x3 = 3mm thick
- FWPS39-10x5 = 5mm thick
- FWPS39-10x10 = 10mm thick

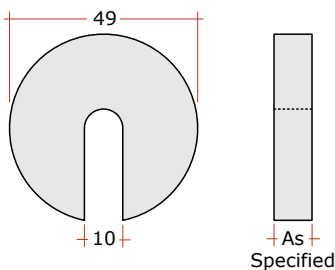

FWPS49-10XXX SPACER, SLOTTED

UV stabilized Grey polymer slotted spacers which are 49mm OD with a 10mm wide slot. They are available in 1mm, 3mm, 5mm, and 10mm thicknesses.

The last X digit denotes the following thicknesses;

- FWPS49-10x1 = 1mm thick
- FWPS49-10x3 = 3mm thick
- FWPS49-10x5 = 5mm thick
- FWPS49-10x10 = 10mm thick

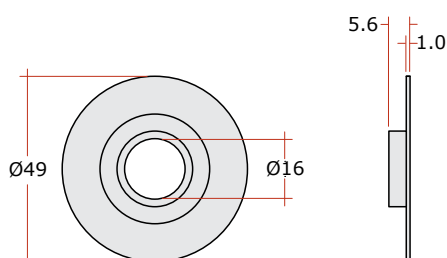

FWBP49-16

WASHER AND BUSH, 49MM OD X 16MM ID POLYMER

UV Stabilized Grey Polymer washer, 49mm OD x 17mm ID x 1mm thickness with bush incorporated. Used between the surfaces of the cap and the glass, and the spacer and the glass.

STAINLESS STEEL TOP RAILS – COMPONENTS

Extrusions & Components



ASG25-12-29

GASKET FOR Q25 TOP RAIL

C-Polymer gasket 2.9m.
To suit 12mm glass with Q25.

Style Specifications



ASG40-XX-58

GASKET FOR Q40 TOP RAIL

To suit 12mm - 17.5mm glass. Various thickness's - see table. Comes in a 5.8m roll.

The two digits in the suffix denote the following glass thickness options;

ASG40-12-58 = For 12mm - 13.5mm glass
ASG40-15-58 = For 14mm - 15mm glass
ASG40-17-58 = For 15mm - 17.5mm glass

Fixing Specifications



ARSC25.XX

Q25 STANDARD END CAP

Push-fit fitting.

The two digits in the suffix denote the following surface finish options;

ARSC25.BK = Black
ARSC25.PF = Mirror polished finish

Assembly Specifications



ARSN25-180.XX

Q25 180° HORIZONTAL CONNECTOR

Rail Joiner – in-line 180°. Firm push-fit fitting.

The two digits in the suffix denote the following surface finish options;

ARSN25-180.BK = Black
ARSN25-180.PF = Mirror polished finish

Fabrication & Installation



ARSN25-90.XX

Q25 90° HORIZONTAL CONNECTOR

Corner jointer - 90°. Firm push-fit fitting.

The two digits in the suffix denote the following surface finish options;

ARSN25-90.BK = Black
ARSN25-90.PF = Mirror polished finish

STAINLESS STEEL TOP RAILS – COMPONENTS (CONT'D)



ARSN25-VSC.XX Q25 VERTICAL SWIVEL CONNECTOR

Variable angle vertical jointer - 0-90°. Achieve up to 45° upwards and downwards for staircase installations.

The two digits in the suffix denote the following surface finish options;

ARSN25-VSC.BK = Black
ARSN25-VSC.PF = Mirror polished finish



ARSN25-HSC.XX Q25 HORIZONTAL SWIVEL CONNECTOR

Variable angle horizontal jointer. Achieve up to 90° left or right angle joining

The two digits in the suffix denote the following surface finish options;

ARSN25-HSC.BK = Black
ARSN25-HSC.PF = Mirror polished finish



ARSW25

Q25 WALL PLATE (VERTICAL)

Vertical wallplate for Q25. Includes grub screw.

The two digits in the suffix denote the following surface finish options;

ARSW25.BK = Black
ARSW25.PF = Mirror polished finish



ARSC40

Q40 STANDARD END CAP

Firm push-fit fitting. Mirror polished finish



ARSW40

Q40 WALL PLATE (VERTICAL)

Grub screw for joining strength.

STAINLESS STEEL TOP RAILS – COMPONENTS (CONT'D)

Extrusions & Components



ARSN40-180

Q40 180° HORIZONTAL CONNECTOR

Firm push-fit fitting. Epoxy glue or drill/tap for joining strength. Mirror polished finish.

Style Specifications

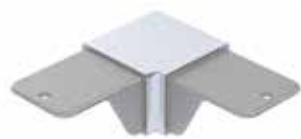

ARSN40-90

Q40 90° HORIZONTAL CONNECTOR

Corner jointer with firm push-fit fitting. Mirror polished finish.

Fixing Specifications



ARSN40-VSC

Q40 VERTICAL SWIVEL CONNECTOR

From straight rail, achieve up to 45° upwards and downwards making it ideal for staircase installations. Mirror polished finish.

Assembly Specifications



ARSN40-HSC

Q40 HORIZONTAL SWIVEL CONNECTOR

From straight rail, achieve up to 90° left or right angle joining. Mirror polished finish.

Fabrication & Installation

MINI POSTS – COMPONENTS

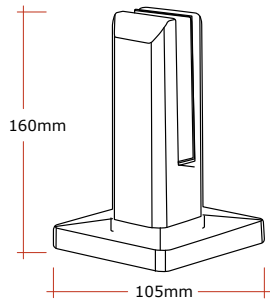

AMQ1-12TJ.XX

GLASSTRUT, TOP MOUNT, SPIGOT

Stainless steel top mount spigot, 160mm high, to suit 12mm glass. Duplex S/S2205. Adjustable cam-lock feature for plumbing the glass. Adjustable base with four grub screws for additional adjustability without requiring packers. The two digits in the suffix denote the following surface finish options;

AMQ1-12TJ.PF	Mirror polished finish
AMQ1-12TJ.BK	Matt Black
AMQ1-12TJ.P1	Powdercoated

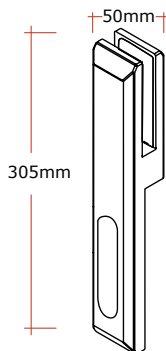

AMQ1-12SF.XX

GLASSTRUT SIDE MOUNT, MINI POST

Stainless steel side mount spigot, 305mm high, to suit 12mm glass. Duplex S/S2205. Adjustable cam-lock feature for plumbing the glass. The two digits in the suffix denote the following surface finish options;

AMQ1-12SF.PF	Mirror polished finish
AMQ1-12SF.BK	Matt Black
AMQ1-12SF.P1	Powdercoated

FASTENERS

The following pages give the part number key for each fastener type.

The current Price List gives actual part numbers (i.e. codes) for individual items which are available.

In the hypothetical codes given for the key guides below: *0* are for digits and *X* are for letters.

Extrusions & Components

Style Specifications

Fixing Specifications

Assembly Specifications

Fabrication & Installation

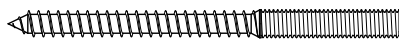

FA10-00

S/S LAG SCREW

Stainless Steel Lag Screw, grade 316 (unless otherwise specified or requested) with M10 thread for engaging with the spacer on one end, and 10mm coach screw thread for engaging into timber substrates on the other end.
The three digits in the suffix denote the entire length in mm, including both set of thread, and any space in between. The length of the M10 male thread is 50mm
FA10-140 is the standard size used.

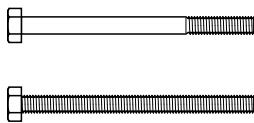

FB0-00

BOLTS, HEX HEAD

Suffix denotes length in mm.
The typical size for Metropolis and Panorama M12 studs into steel is FB12-50 (AZM2) or FB12-40 (AZS3).
The typical size for Arena-Points M10 studs into steel is FB10-40.
The standard size for GlasStrut into steel is M8 or M10 bolts.

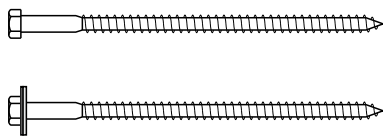

FCS0-00
FCP0-00

COACHSCREWS

1ST NUMBER = Nominal Diameter, mm
2ND NUMBER = Screw Length, mm
SUFFIX: (none) = Stainless Steel
G = Hot Dip Galvanized
FCS0-00 is a coachscrew only.
FCP0-00 is a coachscrew and washer set. For example:
FCP8-165 = FCS8-165, FW8-22 & FWP8-22G



FE0-00

S/S THREADED STUD, EPOXY ANCHORING

Stainless Steel threaded stud, grade 316.
Threaded along entire length, with several options in 20mm and 25mm increments. Custom grade or sizes also available upon request.
Three digit suffix denotes length in mm.

The standard size for Arena-Points into concrete is FE10-140. The standard size for 200 PFC channels is FE10-80. The standard size for M12 studs into concrete is FE12-140 (AZM2) or FE12-150 (AZS3). The standard size for GlasStrut into concrete is M8 or M10 studs.

FASTENERS - (CONT'D)

TAS70-03B

ADHESIVE

Elastic Simson ISR suitable for securing joints with UNEX handrails or firmly securing aesthetic end caps. 290ml cartridge

SUFFIX:

B = Black
G = Grey

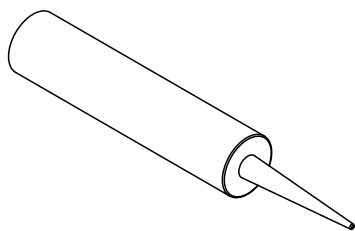

TASV60B

ADHESIVE

Structural Glazing silicone. 290ml cartridge

SUFFIX:

B = Black
C = Clear

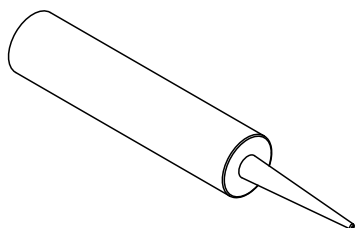

TASG2

ADHESIVE, FOR SUBSTRATE FASTENERS

Adhesive Sika Supergrip 2 Hour. Used to increase substrate fastener pullout load rating, on timber decks in particular situations.

Will apply approx:

80 off FC8-165 top mounted fasteners, or
110 off FC8-165 side mounted fasteners

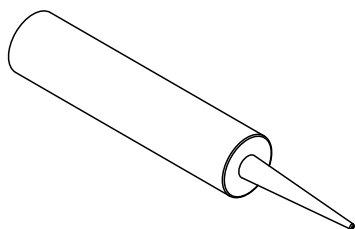

TEC2

EPCON C6 EF

Epcon C6 EF series is classified as a 'Dangerous Goods' and therefore has freight complications.

Epoxy cartridge Epcon C6 EF, 600ml. Will apply approx 63x FE8-105 studs or 45x FE10-115 studs. Nozzles not included.

TEG2

Dispensing gun for TEC epoxy cartridge.

TEN2

Disposable nozzle for TEC epoxy cartridge.



TOOLS & ACCESSORIES

Extrusions & Components



TLG-05L

LANOLIN GREASE

Lanolin grease is used on all zones where S/S threaded fasteners engage with aluminium spacers and caps. The use of Lanolin grease minimizes any reaction between these metals, and enhances durability.

TGL-05L = 0.5 Litres of Grease

Style Specifications

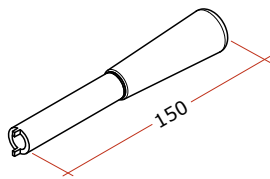

TOA050

ADJUSTMENT TOOL

Adjustment tool that fits onto slotted shank of the back spacers. Allows installers to easily micro-adjust the vertical alignment of the glass from the front.

Fixing Specifications

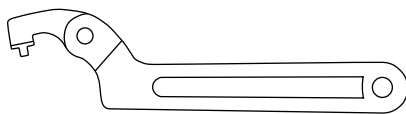

TOT1951

C-HOOK WRENCH

This unique wrench is custom for Arena-Points to make micro-adjustments to vertically align the glass panes from the front and tighten down each point.

Adjustable to fit Ø19-51mm caps.

Assembly Specifications

OTHER FASTENERS AND FIXINGS

A wide range of other Fastener accessories such as bolts, nuts, nyloc nuts, washers, spring washers and screws is also available from UNEX. Enquire from our Customer Support Team on phone 0800 333 777, or email info@unex.co.nz

Fabrication & Installation

CHAPTER 2 - FRAMELESS GLASS STYLE SPECIFICATIONS

Design Wind Speeds : General	48
Design Wind Speeds : NZS 3604	49
Glass Thickness Requirements – Important Notice	50
Balustrade Deflection	51

SPEC ID	STYLE SPECIFICATIONS	
SS.60.00	'Metropolis' (NO Rail)	52
SS.60.12T	'Metropolis' (VRR Top Rail)	53
SS.60.18T	'Metropolis' (Q25 Top Rail)	54
SS.60.19T	'Metropolis' (Q40 Top Rail)	55
SS.60.14S	'Metropolis' (LRR Side Rail)	56
SS.61.00	'Panorama' (NO Rail).....	57
SS.61.12T	'Panorama' (VRR Top Rail)	58
SS.61.18T	'Panorama' (Q25 Top Rail)	59
SS.61.19T	'Panorama' (Q40 Top Rail)	60
SS.61.14S	'Panorama' (LRR Side Rail).....	61
SS.	'Panorama' (Round Stainless Steel Side Side Rail)	62
SS.65.00	'Arena-Points' (No Top Rail).....	63
SS.65.12T	'Arena-Points' (VRR Top Rail).....	64
SS.65.18T	'Arena-Points' (Q25 Top Rail).....	65
SS.65.19T	'Arena-Points' (Q40 Top Rail).....	66
SS.65.12S	'Arena-Points' (VRR Side Rail).....	67
SS.65.14S	'Arena-Points' (LRR Side Rail)	68
SS.66.00T	'GlasStrut Top Fixed' (No Top Rail)	69
SS.66.12T	'GlasStrut Top Fixed' (VRR Top Rail)	70
SS.66.18T	'GlasStrut Top Fixed' (Q25 Stainless Steel Top Rail)	71
SS.66.19T	'GlasStrut Top Fixed' (Q40 Stainless Steel Top Rail)	72
SS.67.00S	'GlasStrut Side Fixed' (No Top Rail)	73
SS.67.12S	'GlasStrut Side Fixed' (No Top Rail)	74
SS.67.18S	'GlasStrut Side Fixed' (Q25 Stainless Steel Top Rail)	75
SS.67.19S	'GlasStrut Side Fixed' (Q40 Stainless Steel Top Rail)	76

DESIGN WIND SPEEDS : GENERAL

- (1) For all balustrade styles with a solid infill e.g. Metropolis, Panorama, or Arena-Points the strength of the members and the fixings must be strong enough to resist the maximum ultimate wind load that is likely to be imposed upon them. This load can be determined from the ultimate Design Wind Speed applicable to the site and the balustrade location in the building.
- (2) The Design Wind Speed must be determined from the appropriate New Zealand loading codes as follows:

- (a) For all balustrades, the ultimate Design Wind Speed should be determined from AS/NZS 1170.2 Wind Actions for use with Loading Class N07C/N07R.

The Design Wind Speed for each building site may be determined from either:

- (i) Directly from the method given in the applicable loading standard.
(ii) By referring to a "qualified engineer", the design engineer for the building, or the Territorial Authority.

- (b) For buildings that are within the scope of NZS 3604:1999.

- (c) The ultimate Design Wind Speed for residential type buildings should be determined from NZS 4203:2016 for use with No Fall Loading Class.

- (3) In this manual, design wind pressures on external glazed or solid infill balustrade panels have been calculated from the formula below:

$$p_u = 0.6 C_{pn} V_d^2$$

Where:

p_u = the nett wind pressure on the infill in Pascals

C_{pn} = 1.2 and is defined in AS/NZS 1170.2 Appendix D

V_d = the ultimate design wind speed in metres per second derived from the appropriate standard for the balustrades location and position.

The above value of C_{pn} is appropriate for most balustrade situations, a higher value will apply where:

- (a) the balustrade has a free end, i.e. it does not return to the building or the return has an open construction such as balusters.
(b) a balustrade on a roof top.

In these situations, reference should be made to a "qualified engineer" or "Wind Consultant" to determine an appropriate value for C_{pn} . Using this value of C_{pn} , calculate a revised value of effective wind speed V_e to determine the post or clamp spacing and glass thickness required from the tables in this Manual.

Where:

$$V_e = 0.91 V_d C_{pn}^{1/2}$$

Where:

V_d = the wind speed determined generally for this building

DESIGN WIND SPEEDS: NZS 3604

This method was the procedure given in NZS 3604:2011 to establish a Wind Zone and a corresponding Ultimate Design Wind Speed for a particular site. Pending the revision of NZS 3604 to align with AS/NZS 1170, this method should only be used for barriers on timber framed residences with the consent of the Territorial Authority.

The Table below utilises the procedure given in Chapter 5 of NZS 3604:2011 *Timber Framed Buildings*. By following the steps in Table 5, an appropriate "Wind Zone" can be established for most building sites i.e. Low, Medium, High, Very High, or Extremely High.

These zones can be converted to Design Wind Speeds from the following Table.

WIND ZONE From Table 5.1 of NZS 3604:2011	DESIGN WIND SPEED (m/s)
L or M	37
H	44
VH	50
EH	55

These Wind Speeds can be used in the tables in Style Specification and Fixing Specification chapters to determine the post or clamp spacing for any balustrade.

GLASS REQUIREMENTS – IMPORTANT NOTICE

1. GLASS MANUFACTURED TO AS/NZS 2208

All glass used in balustrading shall be Grade A Toughened Safety Glass, or Toughened-Laminated Safety Glass where specified, manufactured by a reputable glass manufacturer to meet the requirements of AS/NZS 2208. Glass shall be selected and used in accordance with the requirements of NZS 4223:2016, which should be referred to for a full guide.

2. TOUGHENED LAMINATED SAFETY GLASS

For Toughened-Laminated Safety Glass, refer to the supplier for suitability of the interlayer lamination in the location where it is being used. Some suppliers may allow for some delamination (causing an opaque frosted effect) over a period of time. UNEX Systems does not take responsibility for the suitability of the interlayer lamination.

3. GLASS THICKNESSES

The recently introduced Loading Code AS/NZS 1170 includes significant point loads on the glass edges. At the time of printing this manual, neither Standards New Zealand nor the Department of Building and Housing had published data on the required thickness of glass to withstand these loads. Additionally the glass thickness cannot be calculated by normal engineering methods.

The glass thicknesses and spans given in this manual are therefore based on either NZS 4223: Part 3:2016, AS 1288, previously published data from Glass Supply companies, or on the results of a series of point load tests conducted by UNEX. It is believed to be the most accurate information available at the time of publication to comply with the Building Code.

Please note however, that further research together with subsequent changes to the Building Code or other standards may modify some or all of this information.

BALUSTRADE DEFLECTION

GENERAL OVERVIEW

Balustrade deflection refers to the degree of 'movement' of the balustrade when certain load is applied. The practical relevance of this deflection relates to the subjective feeling one may experience when asserting a force on the balustrade, as excessive movement may cause a sense of apprehension. Deflection should not be confused with safety in respect of the ultimate balustrade strength to resist failure. A guideline for the amount of balustrade deflection deemed acceptable can be derived from "Guidance on Barrier Design" March 2012, published by what was then the Department of Building and Housing. Below are several relevant excerpts from clause 3.5 of this document relating to balustrade deflection. The original document should be referred to directly for further information if required.

- "Beyond the NZBC requirements for barriers to be of adequate strength and stiffness to sustain the applied loads without causing loss of amenity through undue deflection, there are no further mandatory requirements for deflections."
- "The total horizontal displacement is recommended not to exceed 30mm under barrier and wind loads described in B1/VM1."
- "For serviceability, the horizontal deflection of post or clamp and rail balustrade systems (measured at the handrail/top rail) may be considered acceptable if it does not exceed $H/60 + L/240$ or 30mm, whichever is smaller, where H is the height of the handrail/top rail above the top of the supporting structure (deck or slab) and L is the distance between the centres of the supporting posts to the handrail..."

APPLICATION IN THIS MANUAL

The specifications in this manual (Issue 12.0) have been calculated with a target maximum deflection not to exceed 30mm for frameless glass styles. These deflections may be exceeded by up to 10% for some "unlikely to occur" loading combinations.

STYLE SPECIFICATIONS

NZBAL-D13.1 | SPEC ID **SS.60.00**

'METROPOLIS' (NO RAIL)

This is a Style Specification for the Metropolis® Balustrade system. It must only be used in conjunction with a Fixing Specification from pages 110-115, and the Assembly Specification AS.60.00 on Page 130. Installation must be completed in accordance with the Installation Guide on pages 214-217 and all other relevant portions of this manual.

1. Glass shall be TOUGHENED SAFETY LAMINATED GLASS, with "SENTRYGLAS" interlayer, and a minimum nominal thickness specified below. Glass shall be supported and glazed in accordance with NZS 4223, **and shall be a minimum of 100MPa**. All exposed edges to be Flat Polished.
 - i. Where the total thickness is specified as 13.52mm, this is comprised of two 6mm thick panes of toughened glass, plus a 1.52mm thick SentryGlas interlayer, e.g 6+1.52+6=13.52mm.
 - ii. Where the total thickness is specified as 14.28mm, this is comprised of two 6mm thick panes of toughened glass, plus a 2.28mm thick SentryGlas interlayer, e.g 6+2.28+6=14.28mm.
2. Laminated glass is potentially susceptible to some minor delamination on the edges over time. This is not expected to affect the mechanical properties of the product, but it potentially could have some aesthetic effect.

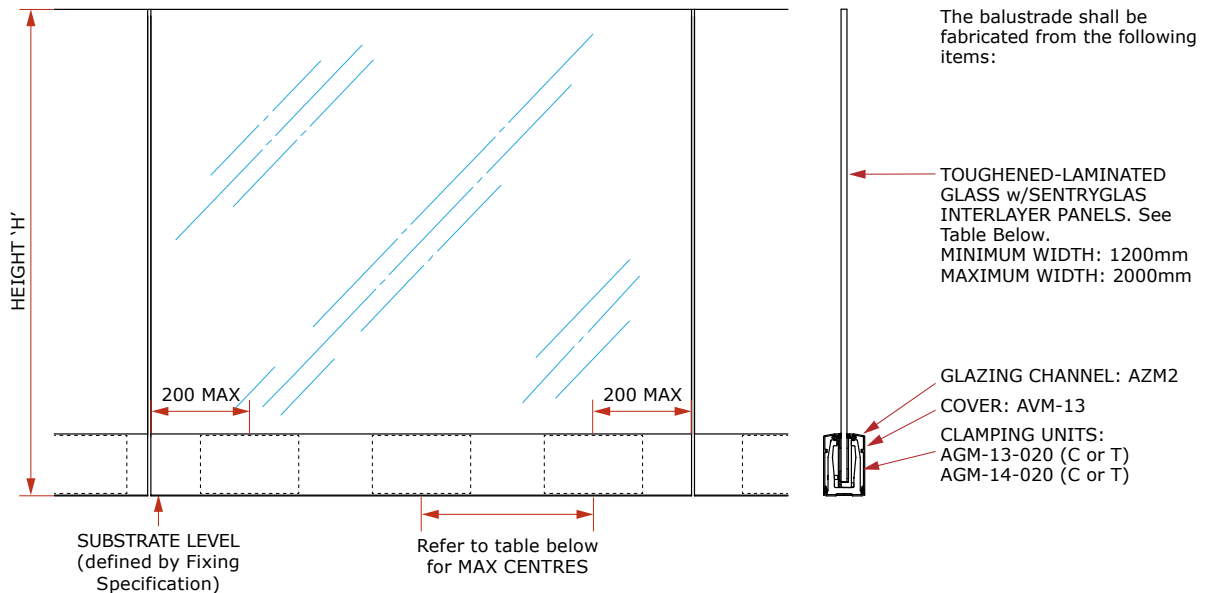

MINIMUM GLASS THICKNESS (MILLIMETRES) & CLAMP CENTRES

HEIGHT ⁽²⁾	Description ⁽⁴⁾	Line No.	LOADING CLASS ⁽¹⁾																	
			N07C/N07R									N03R	Not Preventing Falls							
			Design Wind Speed ⁽³⁾										Design Wind Speed ⁽³⁾							
			VH			EH							M			H			VH	
50	52	54	56	58	60	62	64		38	40	42	44	46	48	50	52	54	56		
1.0	Maximum Clamping Set Centres (13.52mm SentryGlas) ⁽⁵⁾	1	400	400	400	380	360	340	320	300	400	400	400	400	400	400	400	400	400	380
1.1	Maximum Clamping Set Centres (13.52mm SentryGlas) ⁽⁵⁾	4	400	400	380	360	320	300	*	*	400	400	400	400	400	400	400	400	380	360
1.2	Maximum Clamping Set Centres (14.28mm SentryGlas) ⁽⁵⁾	6	400	380	340	320	300	*	*	*	400	400	400	400	400	400	400	380	340	320

1. LOADING CLASS: Refer to Page 175 for the scope of the Loading Class designations.
 2. HEIGHT 'H': is the overall height of the balustrade above the substrate level shown. Interpolate for Heights between those shown.
 3. DESIGN WIND SPEED: in m/s, Refer to Pages 48-49 for details of applicable wind codes and the methods for determining the Design Wind Speed.
 4. CLAMPING SET CENTRES: Figures given are the maximum spacing in mm. Refer to Chapter 5 for method of determining actual spacing required.
 5. Refer to header point #1 to define SentryGlas interlayer and overall glass thickness.
 * These wind speeds are achievable however they require Site Specific Engineering Designs

'METROPOLIS' (VRR TOP RAIL)

This is a Style Specification for the Metropolis® Balustrade system. It must only be used in conjunction with a Fixing Specification from pages 110-115, and the Assembly Specification AS.60.12T on Page 134. Installation must be completed in accordance with the Installation Guide on pages 214-217 and all other relevant portions of this manual.

1. Glass shall be GRADE A SAFETY GLASS, TOUGHENED in accordance with AS/NZS 2208, with a minimum thickness as determined from Table below. Glass shall be supported and glazed in accordance with NZS 4223, **and shall be a minimum of 100MPa**. All exposed edges to be Flat Polished.
2. The top rail shall be attached to the top edge of the glass with structural silicone, for the full length of the rail and for the full width of the glass. The top rail ends shall be structurally attached to a building element to transfer a load of 900 Newtons in any direction. At any joins or corners, the top rail shall be structurally gusseted to transfer a load of 900 Newtons in any direction.
3. A Top Rail is not required on the Frameless Glass styles if not preventing a fall of 1.0m or more.

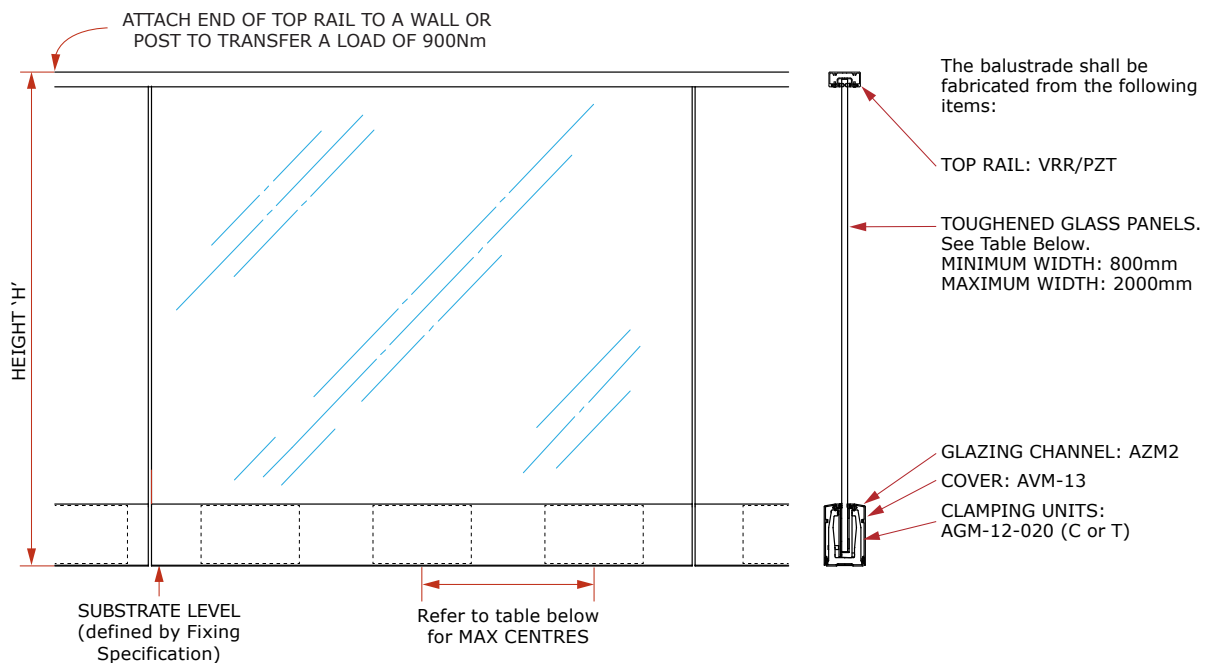

MINIMUM GLASS THICKNESS (MILLIMETRES) & CLAMP CENTRES

HEIGHT ⁽²⁾	Description ⁽⁴⁾	Line No.	LOADING CLASS ⁽¹⁾																	
			N07C/N07R									N03R	Not Preventing Falls							
			Design Wind Speed ⁽³⁾										Design Wind Speed ⁽³⁾							
			VH			EH							M			H			VH	
50	52	54	56	58	60	62	64	N/A	38	40	42	44	46	48	50	52	54	56		
1.0	Maximum Clamping Set Centres (12mm Toughened)	1	400	400	400	400	400	400	*	*	400	400	400	400	400	400	400	400	400	400
1.1	Maximum Clamping Set Centres (12mm Toughened)	4	400	400	400	380	360	*	*	*	400	400	400	400	400	400	400	400	400	380
1.2	Maximum Clamping Set Centres (12mm Toughened)	6	400	*	*	*	*	*	*	*	400	400	400	400	400	400	400	380	340	320

1. LOADING CLASS: Refer to Page 175 for the scope of the Loading Class designations.
 2. HEIGHT 'H': is the overall height of the balustrade above the substrate level shown. Interpolate for Heights between those shown.
 3. DESIGN WIND SPEED: in m/s, Refer to Pages 48-49 for details of applicable wind codes and the methods for determining the Design Wind Speed.
 4. CLAMPING SET CENTRES: Figures given are the maximum spacing in mm. Refer to Chapter 5 for method of determining actual spacing required.
 5. * These wind speeds are achievable however they require Site Specific Engineering Designs

STYLE SPECIFICATIONS

NZBAL-D13.1 | SPEC ID **SS.60.18T**

'METROPOLIS' (Q25 STAINLESS STEEL TOP RAIL)

This is a Style Specification for the Metropolis® Balustrade system. It must only be used in conjunction with a Fixing Specification from pages 110-115, and the Assembly Specification AS.60.18T on Page 137. Installation must be completed in accordance with the Installation Guide on pages 214-217 and all other relevant portions of this manual.

1. Glass shall be GRADE A SAFETY GLASS, TOUGHENED in accordance with AS/NZS 2208, with a minimum thickness as determined from Table below. Glass shall be supported and glazed in accordance with NZS 4223, **and shall be a minimum of 100MPa**. All exposed edges to be Flat Polished.
2. The top rail shall be attached to the top edge of the glass with structural silicone, for the full length of the rail and for the full width of the glass. The top rail ends shall be structurally attached to a building element to transfer a load of 900 Newtons in any direction. At any joins or corners, the top rail shall be structurally gusseted to transfer a load of 900 Newtons in any direction.
3. A Top Rail is not required on the Frameless Glass styles if not preventing a fall of 1.0m or more.

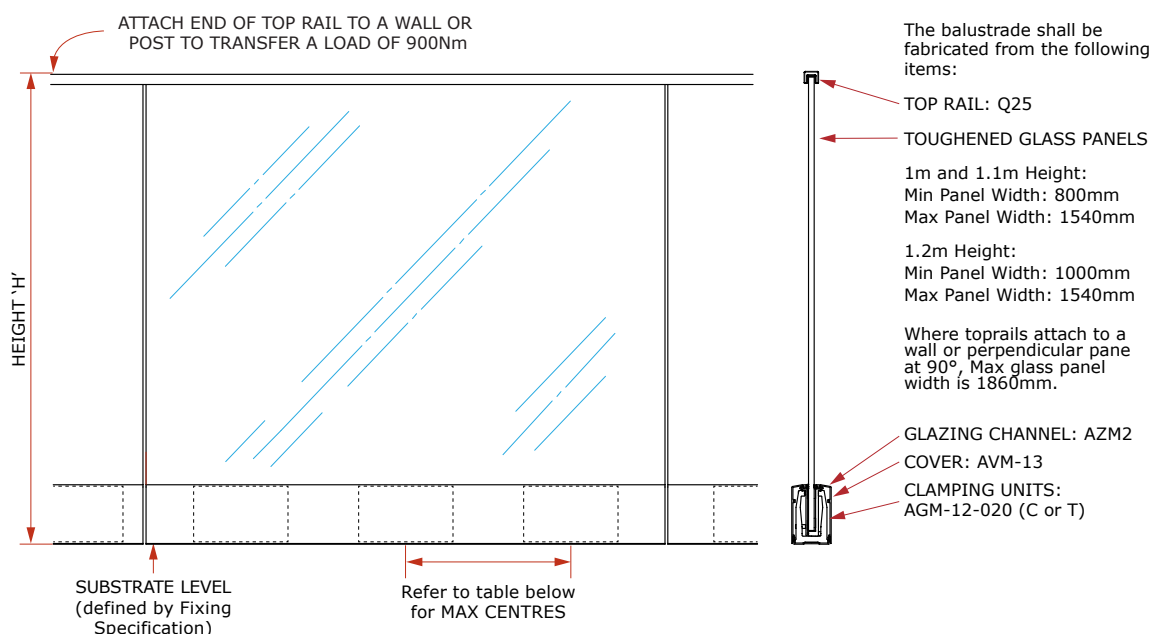

MINIMUM GLASS THICKNESS (MILLIMETRES) & CLAMP CENTRES

HEIGHT ⁽²⁾	Description ⁽⁴⁾	Line No.	LOADING CLASS ⁽¹⁾																	
			N07C/N07R									N03R	Not Preventing Falls							
			Design Wind Speed ⁽³⁾										Design Wind Speed ⁽³⁾							
			VH			EH							M		H		VH		EH	
50	52	54	56	58	60	62	64	N/A	38	40	42	44	46	48	50	52	54	56		
1.0	Maximum Clamping Set Centres (12mm Toughened)	1	400	400	400	400	400	400	*	*	400	400	400	400	400	400	400	400	400	400
1.1	Maximum Clamping Set Centres (12mm Toughened)	4	400	400	400	380	360	*	*	*	400	400	400	400	400	400	400	400	400	380
1.2	Maximum Clamping Set Centres (12mm Toughened)	6	400	*	*	*	*	*	*	*	400	400	400	400	400	400	400	380	340	320

1. LOADING CLASS: Refer to Page 175 for the scope of the Loading Class designations.
2. HEIGHT 'H': is the overall height of the balustrade above the substrate level shown. Interpolate for Heights between those shown.
3. DESIGN WIND SPEED: in m/s, Refer to Pages 48-49 for details of applicable wind codes and the methods for determining the Design Wind Speed.
4. CLAMPING SET CENTRES: Figures given are the maximum spacing in mm. Refer to Chapter 5 for method of determining actual spacing required.
5. Refer to header point #1 to define SentryGlas interlayer and overall glass thickness.
* These wind speeds are achievable however they require Site Specific Engineering Designs

Specifications subject to change without notice

'METROPOLIS' (Q40 STAINLESS STEEL TOP RAIL)

This is a Style Specification for the Metropolis® Balustrade system. It must only be used in conjunction with a Fixing Specification from pages 110-115, and the Assembly Specification AS.60.19T on Page 138. Installation must be completed in accordance with the Installation Guide on pages 214-217 and all other relevant portions of this manual.

1. Glass shall be GRADE A SAFETY GLASS, TOUGHENED in accordance with AS/NZS 2208, with a minimum thickness as determined from Table below. Glass shall be supported and glazed in accordance with NZS 4223, **and shall be a minimum of 100MPa**. All exposed edges to be Flat Polished.
2. The top rail shall be attached to the top edge of the glass with structural silicone, for the full length of the rail and for the full width of the glass. The top rail ends shall be structurally attached to a building element to transfer a load of 900 Newtons in any direction. At any joins or corners, the top rail shall be structurally gusseted to transfer a load of 900 Newtons in any direction.
3. A Top Rail is not required on the Frameless Glass styles if not preventing a fall of 1.0m or more.

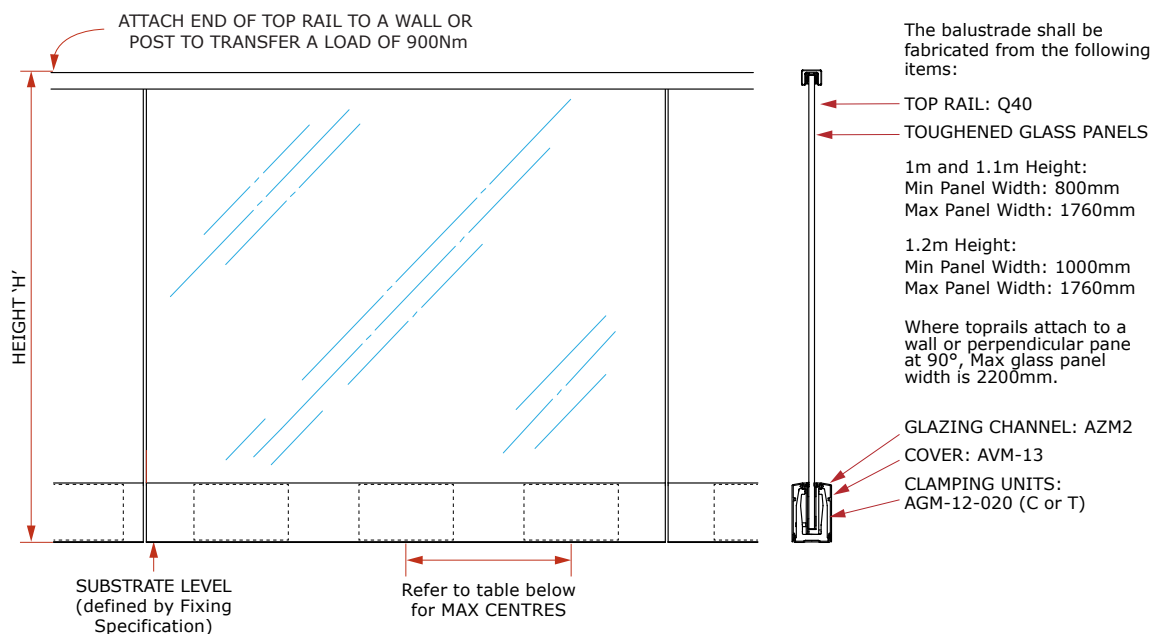

MINIMUM GLASS THICKNESS (MILLIMETRES) & CLAMP CENTRES

HEIGHT ⁽²⁾	Description ⁽⁴⁾	Line No.	LOADING CLASS ⁽¹⁾																	
			N07C/N07R									N03R	Not Preventing Falls							
			Design Wind Speed ⁽³⁾										Design Wind Speed ⁽³⁾							
			VH			EH							M		H		VH		EH	
50	52	54	56	58	60	62	64		38	40	42	44	46	48	50	52	54	56		
1.0	Maximum Clamping Set Centres (12mm Toughened)	1	400	400	400	400	400	400	*	*	400	400	400	400	400	400	400	400	400	400
1.1	Maximum Clamping Set Centres (12mm Toughened)	4	400	400	400	380	360	*	*	*	400	400	400	400	400	400	400	400	400	380
1.2	Maximum Clamping Set Centres (12mm Toughened)	6	400	*	*	*	*	*	*	*	400	400	400	400	400	400	400	380	340	320

1. **LOADING CLASS:** Refer to Page 175 for the scope of the Loading Class designations.
 2. **HEIGHT 'H':** is the overall height of the balustrade above the substrate level shown. Interpolate for Heights between those shown.
 3. **DESIGN WIND SPEED:** in m/s, Refer to Pages 48-49 for details of applicable wind codes and the methods for determining the Design Wind Speed.
 4. **CLAMPING SET CENTRES:** Figures given are the maximum spacing in mm. Refer to Chapter 5 for method of determining actual spacing required.
 5. Refer to header point #1 to define SentryGlas interlayer and overall glass thickness.
 * These wind speeds are achievable however they require Site Specific Engineering Designs

STYLE SPECIFICATIONS

NZBAL-D13.1 | SPEC ID **SS.60.14S**

'METROPOLIS' (LRR SIDE RAIL)

This is a Style Specification for the Metropolis® Balustrade system. It must only be used in conjunction with a Fixing Specification from pages 116-119, and the Assembly Specification AS.61.14S on Page 159. Installation must be completed in accordance with the Installation Guide on pages 218-222 and all other relevant portions of this manual.

1. Glass shall be GRADE A SAFETY GLASS, TOUGHENED in accordance with AS/NZS 2208, with a minimum thickness as determined from Table below. Glass shall be supported and glazed in accordance with NZS 4223, **and shall be a minimum of 100MPa**. All exposed edges to be flat polished.
2. The side rail shall connect to the glass with LRWG brackets. Each pane of glass shall have at least two of these brackets. The side rail ends shall be structurally attached to a building element to transfer a load of 900 Newtons in any direction. At any joins or corners, the top rail shall be structurally gusseted to transfer a load of 900 Newtons in any direction.
3. A Side Rail is not required on the Frameless Glass styles if not preventing a fall of 1.0m or more.
4. ***IMPORTANT NOTE*** Side Rail height shall not be less than the minimum barrier height, as required in F4/AS1.

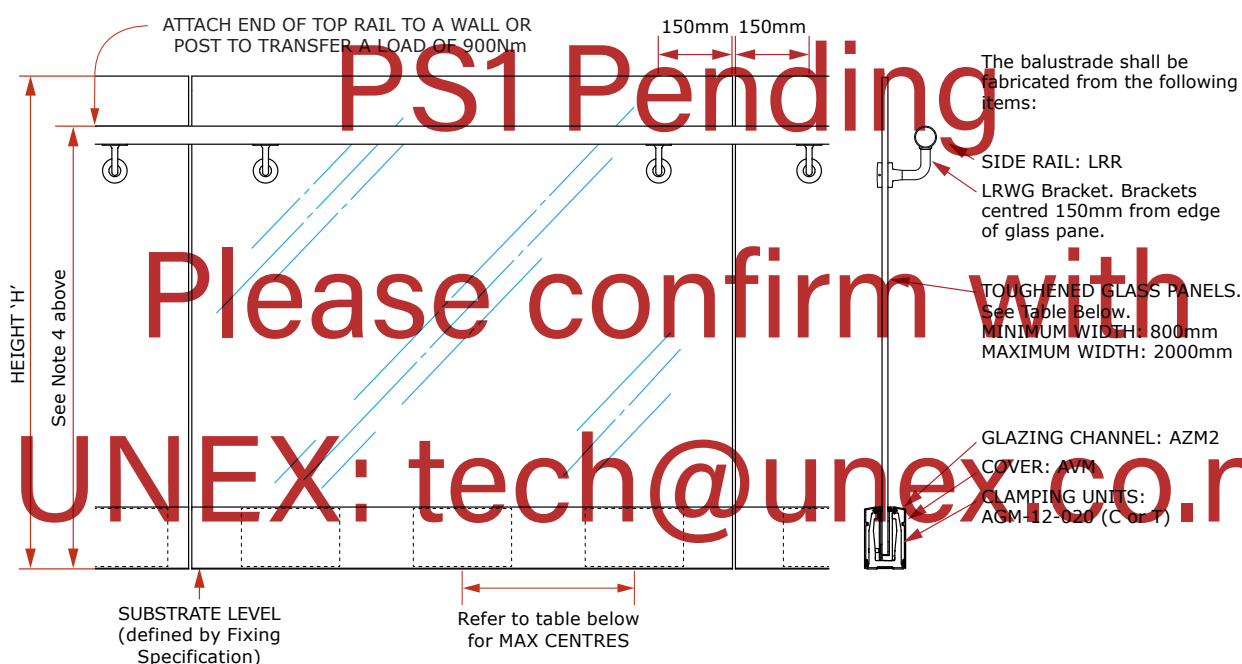

'PANORAMA' (NO RAIL)

This is a Style Specification for the Panorama® Balustrade system. It must only be used in conjunction with a Fixing Specification from pages 116-119, and the Assembly Specification AS.61.00 on Page 145. Installation must be completed in accordance with the Installation Guide on pages 218-222 and all other relevant portions of this manual.

1. Glass shall be TOUGHENED SAFETY LAMINATED GLASS, with "SENTRYGLAS" interlayer, and a minimum nominal thickness specified below. Glass shall be supported and glazed in accordance with NZS 4223, **and shall be a minimum of 100MPa**. Exposed edges to be flat polished.
 - i. Where the total thickness is specified as 13.52mm, this is comprised of two 6mm thick panes of toughened glass, plus a 1.52mm thick SentryGlas interlayer, e.g 6+1.52+6=13.52mm.
 - ii. Where the total thickness is specified as 14.28mm, this is comprised of two 6mm thick panes of toughened glass, plus a 2.28mm thick SentryGlas interlayer, e.g 6+2.28+6=14.28mm.
 - iii. Where the total thickness is specified as 16.28mm, this is comprised of a 6mm thick pane and an 8mm thick pane of toughened glass (**which 8mm must be on the deck side of the balustrade**) plus a 2.28mm thick SentryGlas interlayer, e.g 6+2.28+8=16.28mm.
2. Laminated glass is potentially susceptible to some minor delamination on the edges over time. This is not expected to affect the mechanical properties of the product, but it potentially could have some aesthetic effect.

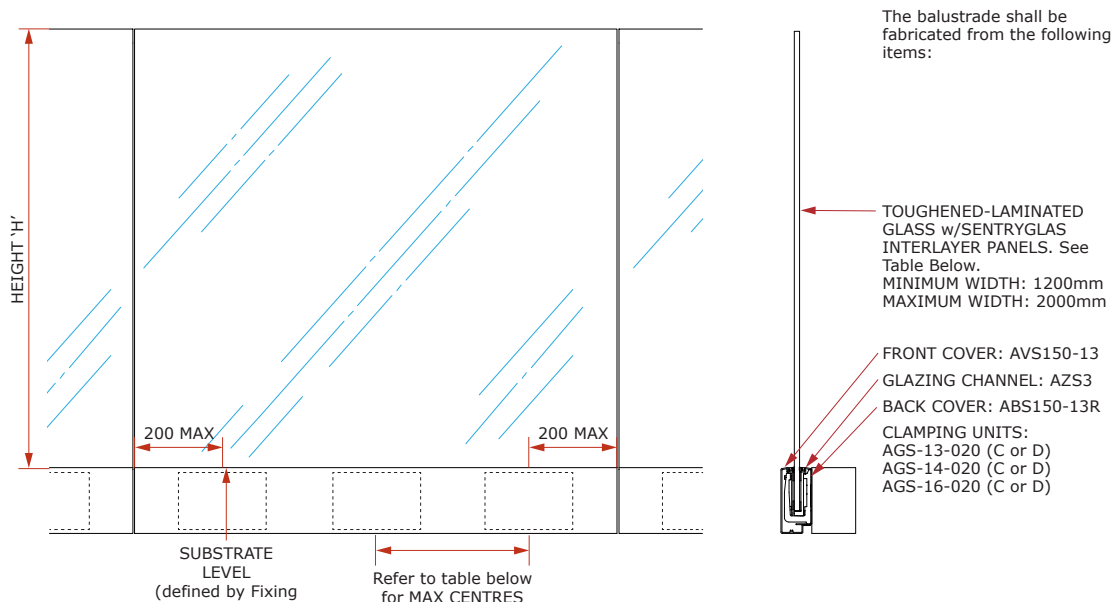

MINIMUM GLASS THICKNESS (MILLIMETRES) & CLAMP CENTRES																				
HEIGHT ⁽²⁾	Description ⁽⁴⁾	Line No.	LOADING CLASS ⁽¹⁾																	
			N07C/N07R									N03R	Not Preventing Falls							
			Design Wind Speed ⁽³⁾										Design Wind Speed ⁽³⁾							
			VH			EH							M			H			VH	
50	52	54	56	58	60	62	64	N/A	38	40	42	44	46	48	50	52	54	56		
1.0	Maximum Clamping Set Centres (13.52mm SentryGlas) ⁽⁵⁾	1	400	400	400	380	360	340	320	300	400	400	400	400	400	400	400	400	400	380
1.1	Maximum Clamping Set Centres (14.28mm SentryGlas) ⁽⁵⁾	4	400	400	380	360	320	300	*	*	400	400	400	400	400	400	400	400	380	360
1.2	Maximum Clamping Set Centres (16.28mm SentryGlas) ⁽⁵⁾	6	400	380	340	320	*	*	*	*	400	400	400	400	400	400	400	380	340	320

1. LOADING CLASS: Refer to Page 175 for the scope of the Loading Class designations.
 2. HEIGHT 'H': is the overall height of the balustrade above the substrate level shown. Interpolate for Heights between those shown.
 3. DESIGN WIND SPEED: in m/s, Refer to Pages 48-49 for details of applicable wind codes and the methods for determining the Design Wind Speed.
 4. CLAMPING SET CENTRES: Figures given are the maximum spacing in mm. Refer to Chapter 5 for method of determining actual spacing required.
 5. Refer to header point #1 to define SentryGlas interlayer and overall glass thickness.
 * These wind speeds are achievable however they require Site Specific Engineering Designs

STYLE SPECIFICATIONS

NZBAL-D13.1 | SPEC ID SS.61.12T

'PANORAMA' (VRR TOP RAIL)

This is a Style Specification for the Panorama® Balustrade system. It must only be used in conjunction with a Fixing Specification from pages 116-119, and the Assembly Specification AS.61.12T on Page 149. Installation must be completed in accordance with the Installation Guide on pages 218-222 and all other relevant portions of this manual.

1. Glass shall be GRADE A SAFETY GLASS, TOUGHENED in accordance with AS/NZS 2208, with a minimum thickness as determined from Table below. Glass shall be supported and glazed in accordance with NZS 4223, **and shall be a minimum of 100MPa**. All exposed edges to be flat polished.
2. The top rail shall be attached to the top edge of the glass with structural silicone, for the full length of the rail and for the full width of the glass. The top rail ends shall be structurally attached to a building element to transfer a load of 900 Newtons in any direction. At any joins or corners, the top rail shall be structurally gusseted to transfer a load of 900 Newtons in any direction.
3. A Top Rail is not required on the Frameless Glass styles if not preventing a fall of 1.0m or more.

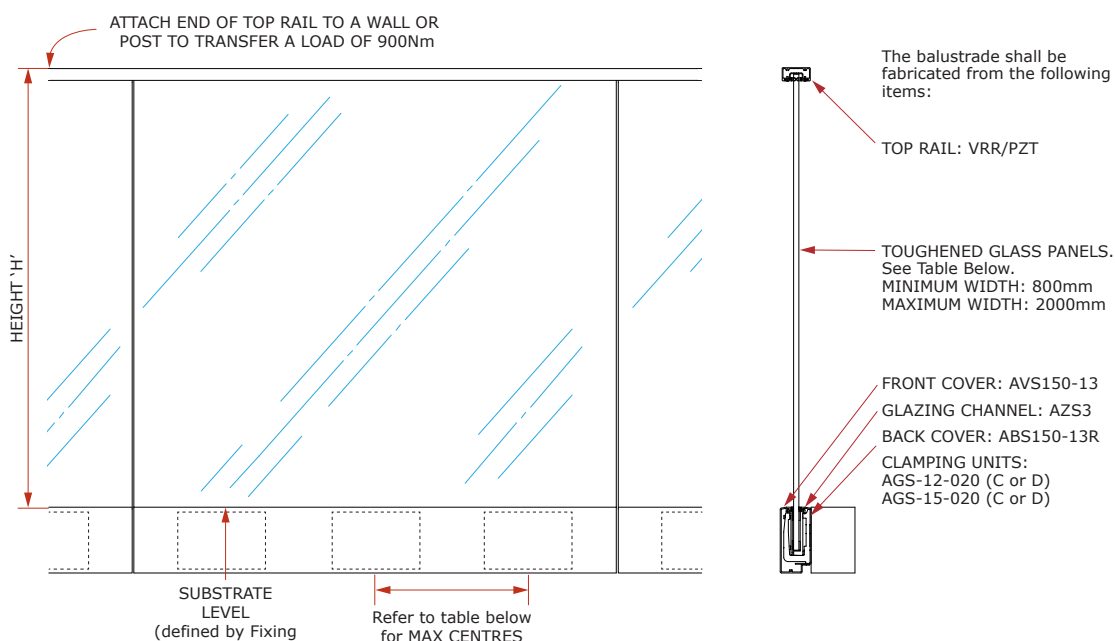

MINIMUM GLASS THICKNESS (MILLIMETRES) & CLAMP CENTRES

HEIGHT ⁽²⁾	Description ⁽⁴⁾	Line No.	LOADING CLASS ⁽¹⁾																	
			N07C/N07R									N03R	Not Preventing Falls							
			Design Wind Speed ⁽³⁾										Design Wind Speed ⁽³⁾							
			VH			EH							M		H		VH		EH	
50	52	54	56	58	60	62	64	N/A	38	40	42	44	46	48	50	52	54	56		
1.0	Maximum Clamping Set Centres (12mm Toughened)	1	400	400	400	380	360	340	*	*	400	400	400	400	400	400	400	400	400	380
1.1	Maximum Clamping Set Centres (12mm Toughened)	4	400	400	380	360	320	*	*	*	400	400	400	400	400	400	400	400	*	*
1.2	Maximum Clamping Set Centres (15mm Toughened)	6	400	*	*	*	*	*	*	*	400	400	400	400	400	400	400	*	*	*

1. LOADING CLASS: Refer to Page 175 for the scope of the Loading Class designations.
2. HEIGHT 'H': is the overall height of the balustrade above the substrate level shown. Interpolate for Heights between those shown.
3. DESIGN WIND SPEED: in m/s, Refer to Pages 48-49 for details of applicable wind codes and the methods for determining the Design Wind Speed.
4. CLAMPING SET CENTRES: Figures given are the maximum spacing in mm. Refer to Chapter 5 for method of determining actual spacing required.
5. Refer to header point #1 to define SentryGlas interlayer and overall glass thickness.
* These wind speeds are achievable however they require Site Specific Engineering Designs

Specifications subject to change without notice

'PANORAMA' (Q25 STAINLESS STEEL TOP RAIL)

This is a Style Specification for the Panorama® Balustrade system. It must only be used in conjunction with a Fixing Specification from pages 116-119, and the Assembly Specification AS.61.18T on Page 152. Installation must be completed in accordance with the Installation Guide on pages 218-222 and all other relevant portions of this manual.

1. Glass shall be GRADE A SAFETY GLASS, TOUGHENED in accordance with AS/NZS 2208, with a minimum thickness as determined from Table below. Glass shall be supported and glazed in accordance with NZS 4223, **and shall be a minimum of 100MPa**. All exposed edges to be flat polished.
2. The top rail shall be attached to the top edge of the glass with structural silicone, for the full length of the rail and for the full width of the glass. The top rail ends shall be structurally attached to a building element to transfer a load of 900 Newtons in any direction. At any joins or corners, the top rail shall be structurally gusseted to transfer a load of 900 Newtons in any direction.
3. A Top Rail is not required on the Frameless Glass styles if not preventing a fall of 1.0m or more.

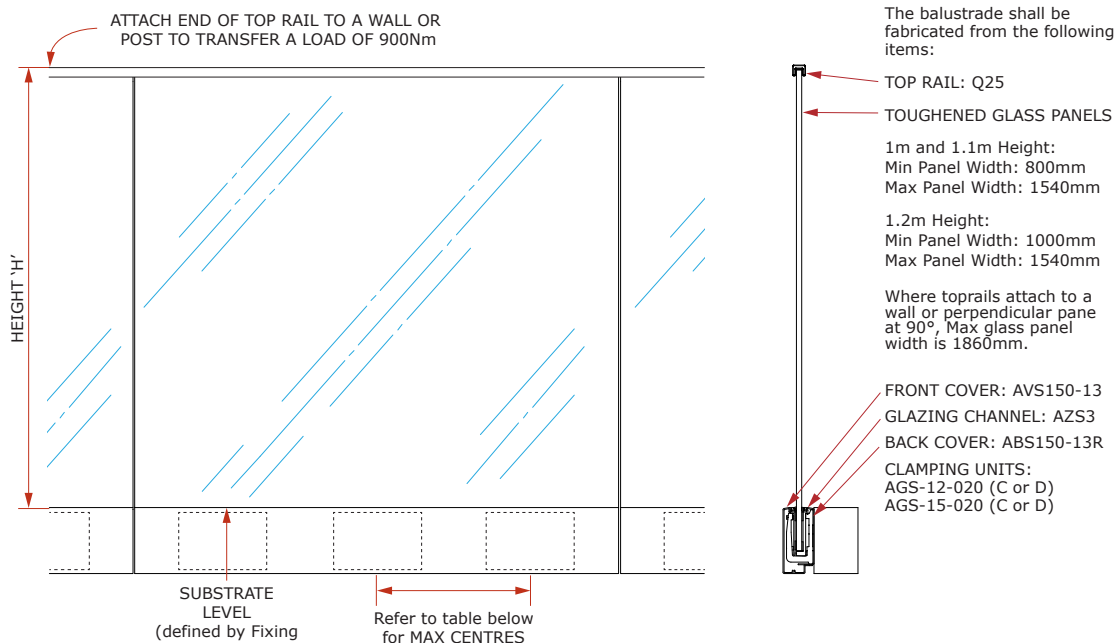

MINIMUM GLASS THICKNESS (MILLIMETRES) & CLAMP CENTRES

HEIGHT ⁽²⁾	Description ⁽⁴⁾	Line No.	LOADING CLASS ⁽¹⁾																				
			N07C/N07R									N03R	Not Preventing Falls										
			Design Wind Speed ⁽³⁾										Design Wind Speed ⁽³⁾										
			VH			EH							M			H			VH			EH	
50	52	54	56	58	60	62	64		38	40	42	44	46	48	50	52	54	56					
1.0	Maximum Clamping Set Centres (12mm Toughened)	1	400	400	400	380	360	340	*	*	400	400	400	400	400	400	400	400	400	400	380		
1.1	Maximum Clamping Set Centres (12mm Toughened)	4	400	400	380	360	320	*	*	*	400	400	400	400	400	400	400	400	400	*	*		
1.2	Maximum Clamping Set Centres (15mm Toughened)	6	400	*	*	*	*	*	*	*	400	400	400	400	400	400	400	400	*	*	*		

1. LOADING CLASS: Refer to Page 175 for the scope of the Loading Class designations.
2. HEIGHT 'H': is the overall height of the balustrade above the substrate level shown. Interpolate for Heights between those shown.
3. DESIGN WIND SPEED: in m/s, Refer to Pages 48-49 for details of applicable wind codes and the methods for determining the Design Wind Speed.
4. CLAMPING SET CENTRES: Figures given are the maximum spacing in mm. Refer to Chapter 5 for method of determining actual spacing required.
5. Refer to header point #1 to define SentryGlas interlayer and overall glass thickness.
* These wind speeds are achievable however they require Site Specific Engineering Designs

STYLE SPECIFICATIONS

NZBAL-D13.1 | SPEC ID SS.61.19T.

'PANORAMA' (Q40 STAINLESS STEEL TOP RAIL)

This is a Style Specification for the Panorama® Balustrade system. It must only be used in conjunction with a Fixing Specification from pages 116-119, and the Assembly Specification AS.61.19T on Page 153. Installation must be completed in accordance with the Installation Guide on pages 218-222 and all other relevant portions of this manual.

1. Glass shall be GRADE A SAFETY GLASS, TOUGHENED in accordance with AS/NZS 2208, with a minimum thickness as determined from Table below. Glass shall be supported and glazed in accordance with NZS 4223, **and shall be a minimum of 100MPa**. All exposed edges to be flat polished.
2. The top rail shall be attached to the top edge of the glass with structural silicone, for the full length of the rail and for the full width of the glass. The top rail ends shall be structurally attached to a building element to transfer a load of 900 Newtons in any direction. At any joins or corners, the top rail shall be structurally gusseted to transfer a load of 900 Newtons in any direction.
3. A Top Rail is not required on the Frameless Glass styles if not preventing a fall of 1.0m or more.

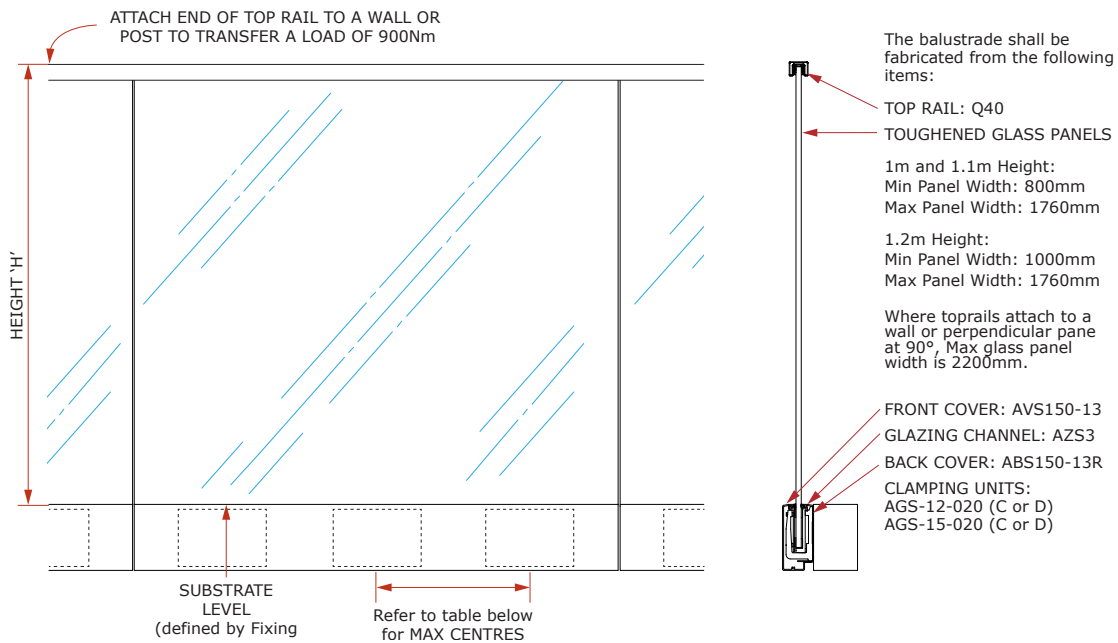

MINIMUM GLASS THICKNESS (MILLIMETRES) & CLAMP CENTRES

HEIGHT ⁽²⁾	Description ⁽⁴⁾	Line No.	LOADING CLASS ⁽¹⁾																	
			N07C/N07R									N03R	Not Preventing Falls							
			Design Wind Speed ⁽³⁾										Design Wind Speed ⁽³⁾							
			VH			EH							M		H		VH		EH	
50	52	54	56	58	60	62	64	N/A	38	40	42	44	46	48	50	52	54	56		
1.0	Maximum Clamping Set Centres (12mm Toughened)	1	400	400	400	380	360	340	*	*	400	400	400	400	400	400	400	400	400	380
1.1	Maximum Clamping Set Centres (12mm Toughened)	4	400	400	380	360	320	*	*	*	400	400	400	400	400	400	400	400	*	*
1.2	Maximum Clamping Set Centres (15mm Toughened)	6	400	*	*	*	*	*	*	*	400	400	400	400	400	400	400	*	*	*

1. LOADING CLASS: Refer to Page 175 for the scope of the Loading Class designations.
 2. HEIGHT 'H': is the overall height of the balustrade above the substrate level shown. Interpolate for Heights between those shown.
 3. DESIGN WIND SPEED: in m/s, Refer to Pages 48-49 for details of applicable wind codes and the methods for determining the Design Wind Speed.
 4. CLAMPING SET CENTRES: Figures given are the maximum spacing in mm. Refer to Chapter 5 for method of determining actual spacing required.
 5. Refer to header point #1 to define SentryGlas interlayer and overall glass thickness.
- * These wind speeds are achievable however they require Site Specific Engineering Designs

'PANORAMA' (LRR SIDE RAIL)

This is a Style Specification for the Panorama® Balustrade system. It must only be used in conjunction with a Fixing Specification from pages 116-119, and the Assembly Specification AS.61.14S on Page 159. Installation must be completed in accordance with the Installation Guide on pages 218-222 and all other relevant portions of this manual.

1. Glass shall be GRADE A SAFETY GLASS, TOUGHENED in accordance with AS/NZS 2208, with a minimum thickness as determined from Table below. Glass shall be supported and glazed in accordance with NZS 4223, **and shall be a minimum of 100MPa**. All exposed edges to be flat polished.
2. The side rail shall connect to the glass with LRWG brackets. Each pane of glass shall have at least two of these brackets. The side rail ends shall be structurally attached to a building element to transfer a load of 900 Newtons in any direction. At any joins or corners, the top rail shall be structurally gusseted to transfer a load of 900 Newtons in any direction.
3. A Side Rail is not required on the Frameless Glass styles if not preventing a fall of 1.0m or more.
4. ***IMPORTANT NOTE*** Side Rail height shall not be less than the minimum barrier height, as required in F4/AS1.

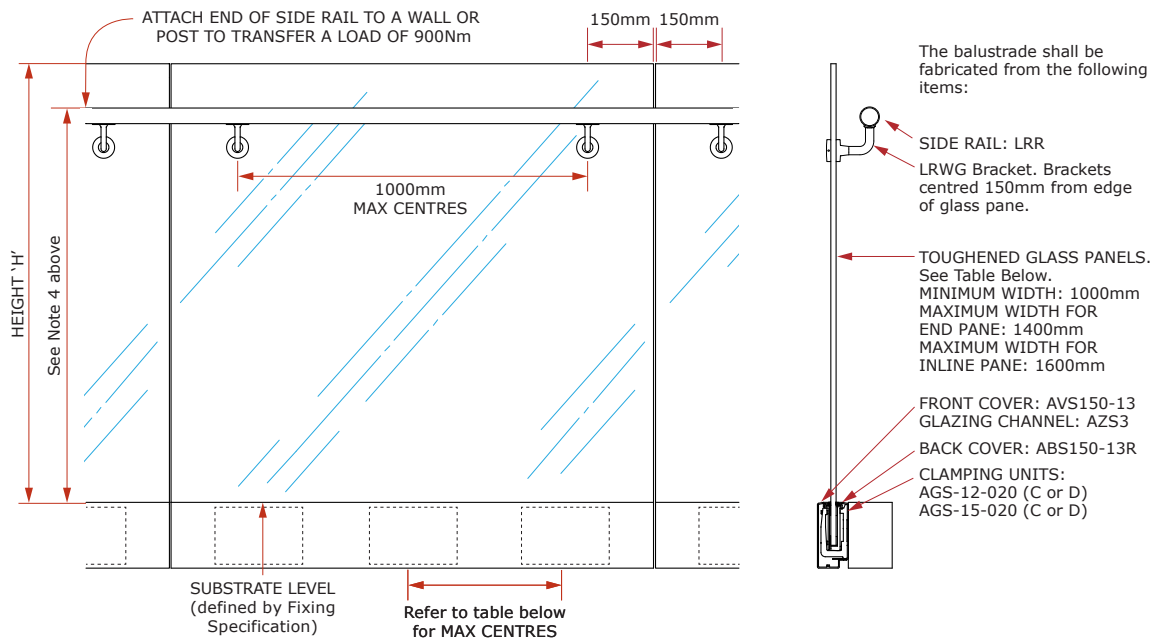

MINIMUM GLASS THICKNESS (MILLIMETRES) & CLAMP CENTRES																				
HEIGHT ⁽²⁾	Description ⁽⁴⁾	Line No.	LOADING CLASS ⁽¹⁾																	
			N07C/N07R									N03R	Not Preventing Falls							
			Design Wind Speed ⁽³⁾										Design Wind Speed ⁽³⁾							
			VH			EH							M			H			VH	
										N/A										
1.0	Maximum Clamping Set Centres (12mm Toughened)	1	400	400	400	380	360	340	*	*	400	400	400	400	400	400	400	400	400	380
1.1	Maximum Clamping Set Centres (12mm Toughened)	4	400	400	380	360	320	*	*	*	400	400	400	400	400	400	400	400	400	*
1.2	Maximum Clamping Set Centres (15mm Toughened)	6	400	*	*	*	*	*	*	*	400	400	400	400	400	400	400	400	*	*

1. LOADING CLASS: Refer to Page 175 for the scope of the Loading Class designations.
 2. HEIGHT 'H': is the overall height of the balustrade above the substrate level shown. Interpolate for Heights between those shown.
 3. DESIGN WIND SPEED: in m/s, Refer to Pages 48-49 for details of applicable wind codes and the methods for determining the Design Wind Speed.
 4. CLAMPING SET CENTRES: Figures given are the maximum spacing in mm. Refer to Chapter 5 for method of determining actual spacing required.
 5. Refer to header point #1 to define SentryGlas interlayer and overall glass thickness.
 * These wind speeds are achievable however they require Site Specific Engineering Designs

STYLE SPECIFICATIONS

NZBAL-D13.1 | SPEC ID SS.61.20S

'PANORAMA' (STAINLESS STEEL SIDE RAIL*)

*44.5mm Ø x 1.5mm Wall Thickness Stainless Steel Circular Tube (Grade 316)

This is a Style Specification for the Panorama® Balustrade system. It must only be used in conjunction with a Fixing Specification from pages 116-119, and the Assembly Specification AS.61.14S on Page 160. Installation must be completed in accordance with the Installation Guide on pages 218-222 and all other relevant portions of this manual.

1. Glass shall be GRADE A SAFETY GLASS, TOUGHENED in accordance with AS/NZS 2208, with a minimum thickness as determined from Table below. Glass shall be supported and glazed in accordance with NZS 4223, **and shall be a minimum of 100MPa**. All exposed edges to be flat polished.
2. The side rail shall connect to the glass with LRWG brackets. Each pane of glass shall have at least two of these brackets. The side rail ends shall be structurally attached to a building element to transfer a load of 900 Newtons in any direction. At any joins or corners, the top rail shall be structurally gusseted to transfer a load of 900 Newtons in any direction.
3. A Side Rail is not required on the Frameless Glass styles if not preventing a fall of 1.0m or more.
4. ***IMPORTANT NOTE*** Side Rail height shall not be less than the minimum barrier height, as required in F4/AS1.

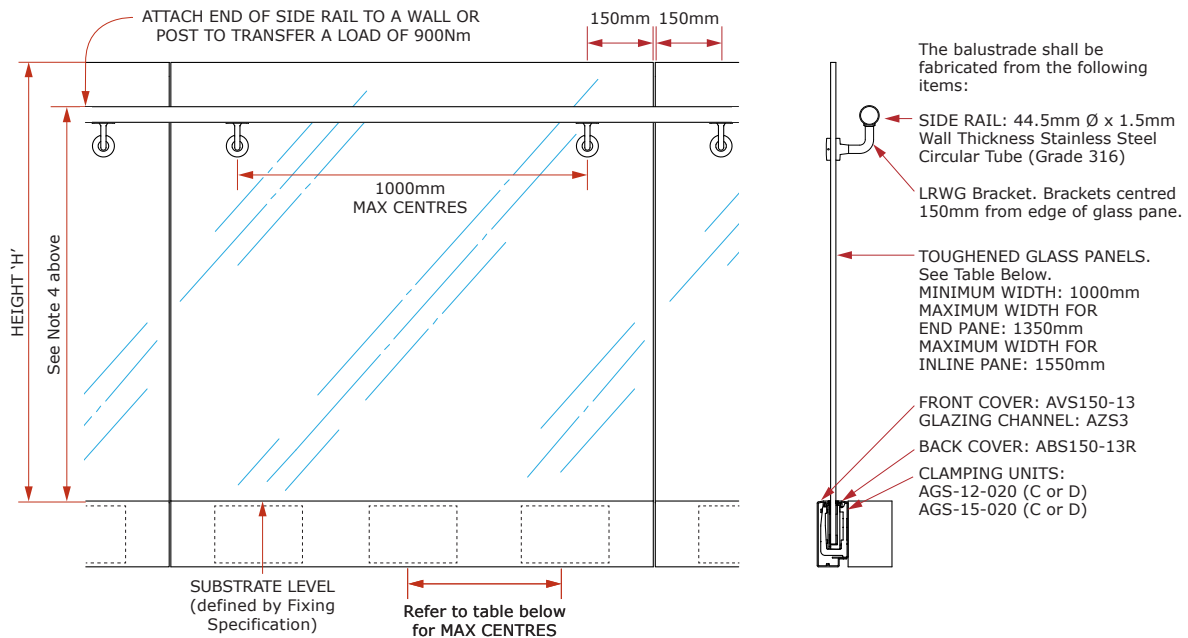

MINIMUM GLASS THICKNESS (MILLIMETRES) & CLAMP CENTRES

HEIGHT ⁽²⁾	Description ⁽⁴⁾	Line No.	LOADING CLASS ⁽¹⁾																	
			N07C/N07R									N03R	Not Preventing Falls							
			Design Wind Speed ⁽³⁾										Design Wind Speed ⁽³⁾							
			VH			EH							M		H		VH		EH	
50	52	54	56	58	60	62	64		38	40	42	44	46	48	50	52	54	56		
1.0	Maximum Clamping Set Centres (12mm Toughened)	1	400	400	400	380	360	340	*	*	400	400	400	400	400	400	400	400	400	380
1.1	Maximum Clamping Set Centres (12mm Toughened)	4	400	400	380	360	320	*	*	*	400	400	400	400	400	400	400	400	*	*
1.2	Maximum Clamping Set Centres (15mm Toughened)	6	400	*	*	*	*	*	*	*	400	400	400	400	400	400	400	*	*	*

1. LOADING CLASS: Refer to Page 175 for the scope of the Loading Class designations.
 2. HEIGHT 'H': is the overall height of the balustrade above the substrate level shown. Interpolate for Heights between those shown.
 3. DESIGN WIND SPEED: in m/s, Refer to Pages 48-49 for details of applicable wind codes and the methods for determining the Design Wind Speed.
 4. CLAMPING SET CENTRES: Figures given are the maximum spacing in mm. Refer to Chapter 5 for method of determining actual spacing required.
 5. Refer to header point #1 to define SentryGlas interlayer and overall glass thickness.
- * These wind speeds are achievable however they require Site Specific Engineering Designs

Specifications subject to change without notice

'ARENA-POINTS' ADJUSTABLE (NO TOP RAIL)

This is a Style Specification for the Arena-Points Balustrade system. It must only be used in conjunction with a Fixing Specification from pages 116-119, and the Assembly Specification AS. on Page 145. Installation must be completed in accordance with the Installation Guide on pages 218-222 and all other relevant portions of this manual.

1. Glass shall be TOUGHENED SAFETY LAMINATED GLASS, with "SENTRYGLAS" interlayer, and a minimum nominal thickness specified below. Glass shall be supported and glazed in accordance with NZS 4223, **and shall be a minimum of 100MPa**. Exposed edges to be flat polished.
 - i. Where the total thickness is specified as 13.52mm, this is comprised of two 6mm thick panes of toughened glass, plus a 1.52mm thick SentryGlas interlayer, e.g $6+1.52+6=13.52\text{mm}$.
 - ii. Where the total thickness is specified as 14.28mm, this is comprised of two 6mm thick panes of toughened glass, plus a 2.28mm thick SentryGlas interlayer, e.g $6+2.28+6=14.28\text{mm}$.
 - iii. Where the total thickness is specified as 16.28mm, this is comprised of a 6mm thick pane and an 8mm thick pane of toughened glass (**which 8mm must be on the deck side of the balustrade**) plus a 2.28mm thick SentryGlas interlayer, e.g $6+2.28+8=16.28\text{mm}$.
2. Laminated glass is potentially susceptible to some minor delamination on the edges over time. This is not expected to affect the mechanical properties of the product, but it potentially could have some aesthetic effect.

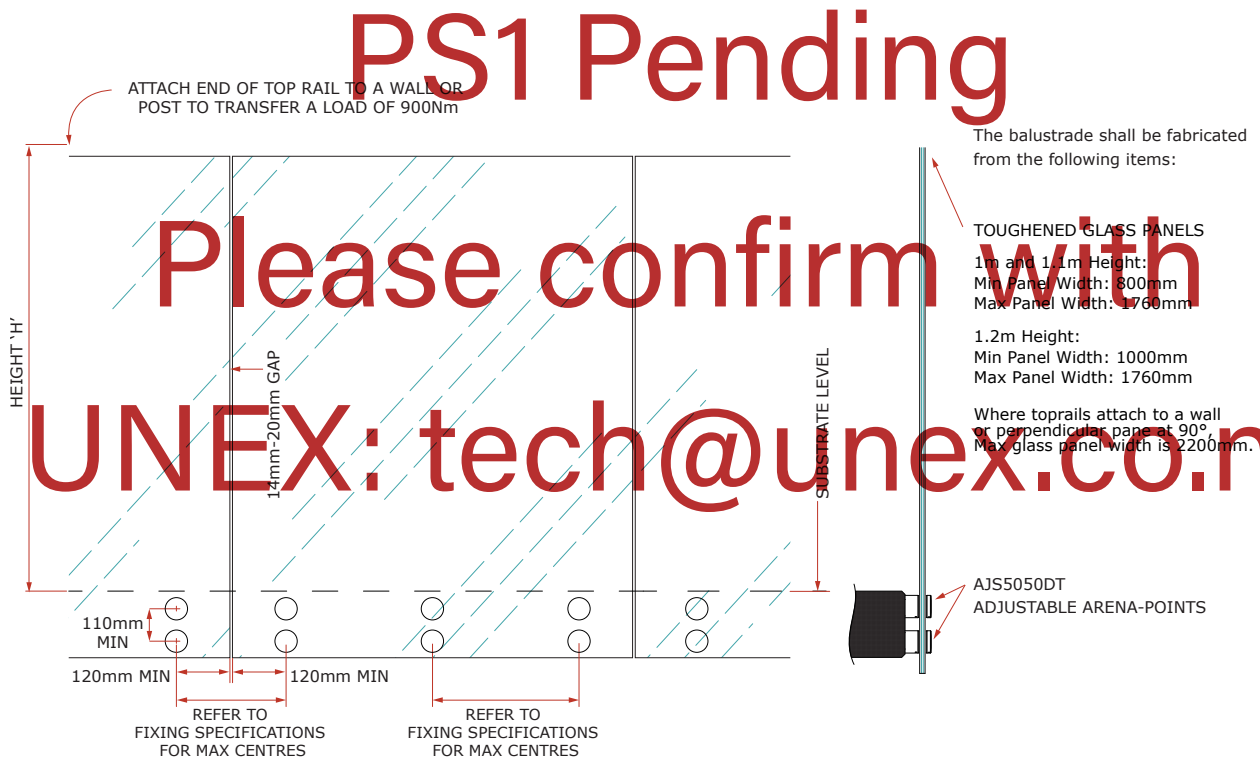

This specification is based on the fixing of the balustrade to the substrate, being as per one of the standard Arena-Points Fixing Specifications in Chapter 3. Refer to the relevant Fixing Specifications in Chapter 3 for minimum glass thickness, and the maximum horizontal spacings allowed for the Arena-Points fittings.

'ARENA-POINTS' ADJUSTABLE (VRR TOP RAIL)

This is a Style Specification for the Arena Points® Balustrade system. It must only be used in conjunction with a Fixing Specification from pages 120-122, and the Assembly Specification AS.65.12T on Page 163. Installation must be completed in accordance with the Installation Guide on pages 223-225 and all other relevant portions of this manual.

1. Glass shall be GRADE A SAFETY GLASS, TOUGHENED in accordance with AS/NZS 2208, with a minimum thickness as determined from Table below. Glass shall be supported and glazed in accordance with NZS 4223, **and shall be a minimum of 100MPa**. All exposed edges to be flat polished.
2. The top rail shall be attached to the top edge of the glass with structural silicone, for the full length of the rail and for the full width of the glass. The top rail ends shall be structurally attached to a building element to transfer a load of 900 Newtons in any direction. At any joins or corners, the top rail shall be structurally gusseted to transfer a load of 900 Newtons in any direction.
3. A Top Rail is not required on the Frameless Glass styles if not preventing a fall of 1.0m or more.
4. The circular holes in the glass for the Arena-Points shall be 26mm Ø.
5. The balustrade shall be constructed such that the geometry of the balustrade shall comply with Acceptable Solutions F4/AS1. This includes the following (but not limited to): The minimum barrier height requirement, the maximum gap allowable and the avoidance of non-complying toeholds

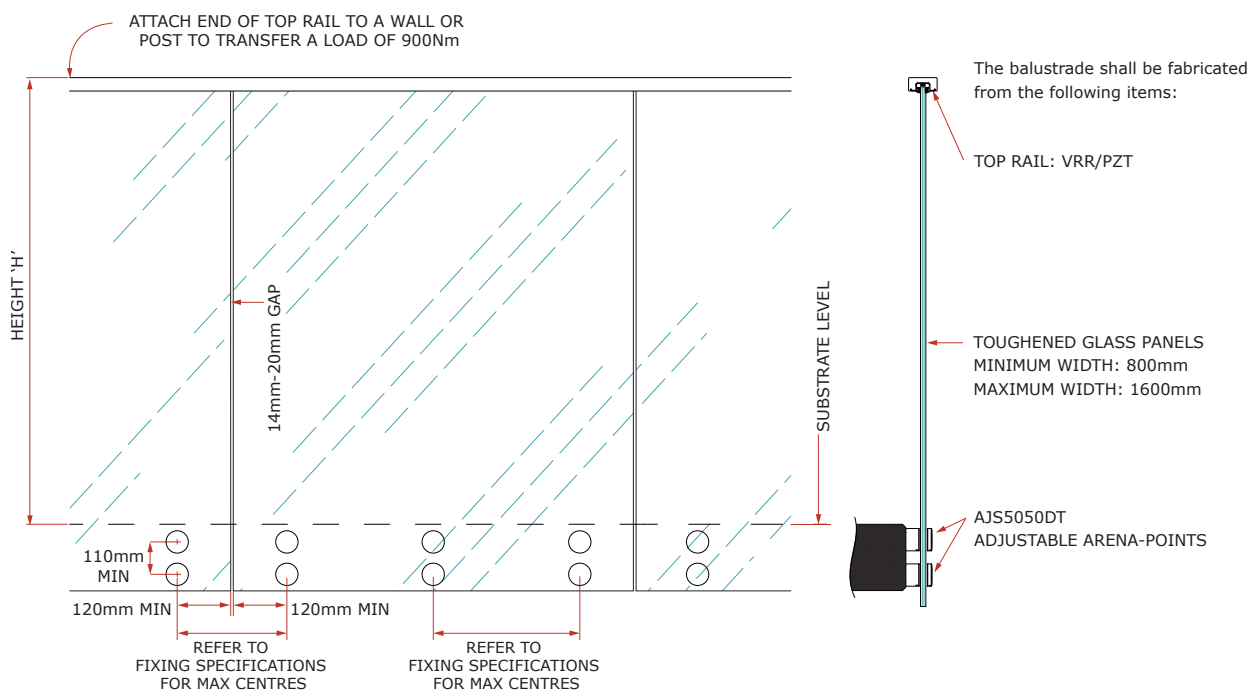

This specification is based on the fixing of the balustrade to the substrate, being as per one of the standard Arena-Points Fixing Specifications in Chapter 3. Refer to the relevant Fixing Specifications in Chapter 3 for minimum glass thickness, and the maximum horizontal spacings allowed for the Arena-Points fittings.

'ARENA-POINTS' ADJUSTABLE (Q25 STAINLESS STEEL TOP RAIL)

This is a Style Specification for the Arena Points® Balustrade system. It must only be used in conjunction with a Fixing Specification from pages 120-122, and the Assembly Specification AS.65.18T on Page 166. Installation must be completed in accordance with the Installation Guide on pages 223-225 and all other relevant portions of this manual.

1. Glass shall be GRADE A SAFETY GLASS, TOUGHENED in accordance with AS/NZS 2208, with a minimum thickness as determined from Table below. Glass shall be supported and glazed in accordance with NZS 4223, **and shall be a minimum of 100MPa**. All exposed edges to be flat polished.
2. The top rail shall be attached to the top edge of the glass with structural silicone, for the full length of the rail and for the full width of the glass. The top rail ends shall be structurally attached to a building element to transfer a load of 900 Newtons in any direction. At any joins or corners, the top rail shall be structurally gusseted to transfer a load of 900 Newtons in any direction.
3. A Top Rail is not required on the Frameless Glass styles if not preventing a fall of 1.0m or more.
4. The circular holes in the glass for the Arena-Points shall be 26mm Ø.
5. The balustrade shall be constructed such that the geometry of the balustrade shall comply with Acceptable Solutions F4/AS1. This includes the following (but not limited to): The minimum barrier height requirement, the maximum gap allowable and the avoidance of non-complying toeholds

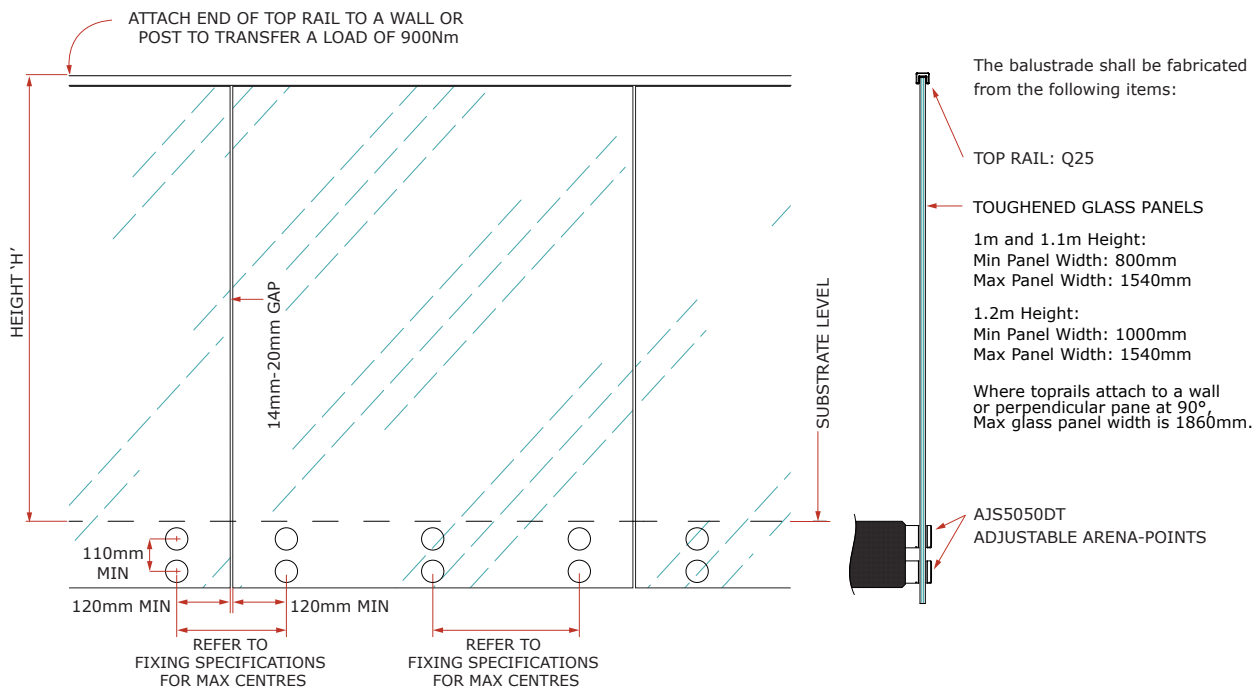

This specification is based on the fixing of the balustrade to the substrate, being as per one of the standard Arena-Points Fixing Specifications in Chapter 3. Refer to the relevant Fixing Specifications in Chapter 3 for minimum glass thickness, and the maximum horizontal spacings allowed for the Arena-Points fittings.

STYLE SPECIFICATIONS

NZBAL-D14.0 | SPEC ID **SS.65.19T**

'ARENA-POINTS' ADJUSTABLE (Q40 STAINLESS STEEL TOP RAIL)

This is a Style Specification for the Arena Points® Balustrade system. It must only be used in conjunction with a Fixing Specification from pages 120-122, and the Assembly Specification AS.65.19T on Page 167. Installation must be completed in accordance with the Installation Guide on pages 223-225 and all other relevant portions of this manual.

1. Glass shall be GRADE A SAFETY GLASS, TOUGHENED in accordance with AS/NZS 2208, with a minimum thickness as determined from Table below. Glass shall be supported and glazed in accordance with NZS 4223, **and shall be a minimum of 100MPa**. All exposed edges to be flat polished.
2. The top rail shall be attached to the top edge of the glass with structural silicone, for the full length of the rail and for the full width of the glass. The top rail ends shall be structurally attached to a building element to transfer a load of 900 Newtons in any direction. At any joins or corners, the top rail shall be structurally gusseted to transfer a load of 900 Newtons in any direction.
3. A Top Rail is not required on the Frameless Glass styles if not preventing a fall of 1.0m or more.
4. The circular holes in the glass for the Arena-Points shall be 26mm Ø.
5. The balustrade shall be constructed such that the geometry of the balustrade shall comply with Acceptable Solutions F4/AS1. This includes the following (but not limited to): The minimum barrier height requirement, the maximum gap allowable and the avoidance of non-complying toeholds

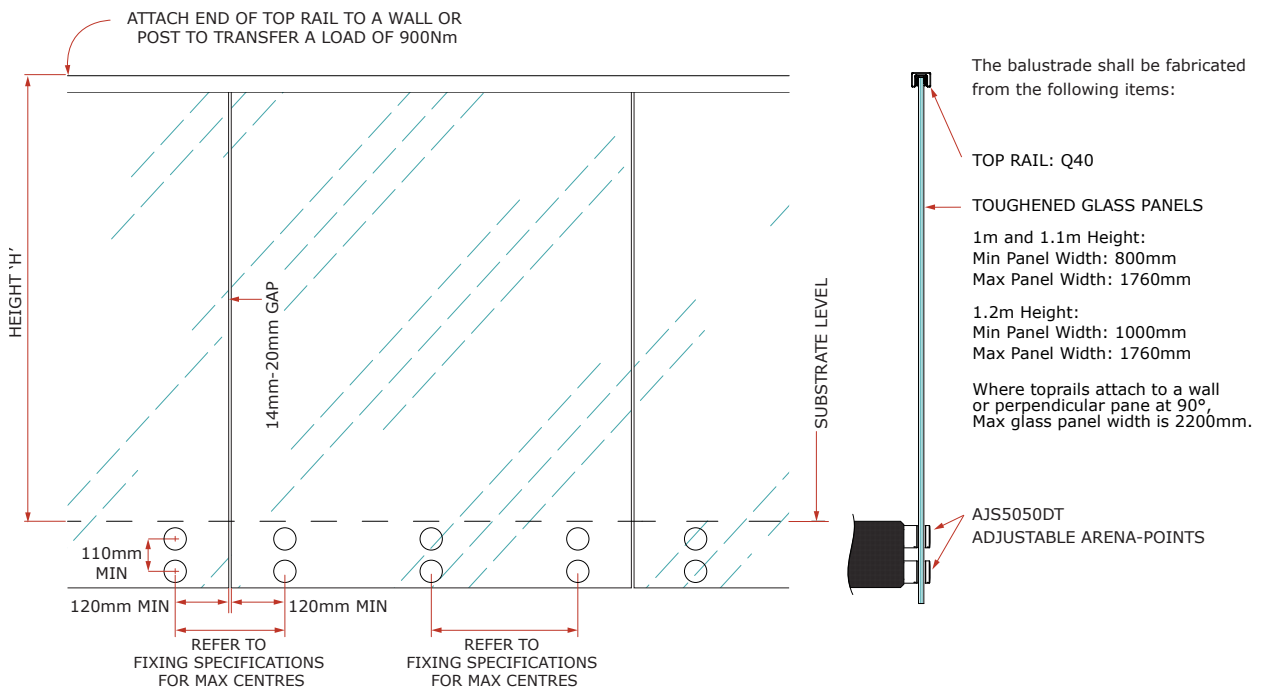

This specification is based on the fixing of the balustrade to the substrate, being as per one of the standard Arena-Points Fixing Specifications in Chapter 3. Refer to the relevant Fixing Specifications in Chapter 3 for minimum glass thickness, and the maximum horizontal spacings allowed for the Arena-Points fittings.

'ARENA-POINTS' ADJUSTABLE (VRR SIDE RAIL)

This is a Style Specification for the Arena Points® Balustrade system. It must only be used in conjunction with a Fixing Specification from pages 120-122, and the Assembly Specification AS.65.12T on Page 175. Installation must be completed in accordance with the Installation Guide on pages 223-225 and all other relevant portions of this manual.

1. Glass shall be GRADE A SAFETY GLASS, TOUGHENED in accordance with AS/NZS 2208, with a minimum thickness as determined from Table below. Glass shall be supported and glazed in accordance with NZS 4223, **and shall be a minimum of 100MPa**. All exposed edges to be flat polished.
2. The side rail shall connect to the glass with LBWG brackets. Each pane of glass shall have at least two of these brackets. The side rail ends shall be structurally attached to a building element to transfer a load of 900 Newtons in any direction. At any joins or corners, the top rail shall be structurally gusseted to transfer a load of 900 Newtons in any direction.
3. A Side Rail is not required on the Frameless Glass styles if not preventing a fall of 1.0m or more.
4. The circular holes in the glass for the Arena-Points shall be 26mm Ø.
5. ***IMPORTANT NOTE*** Side Rail height shall not be less than the minimum barrier height, as required in F4/AS1.
6. The balustrade shall be constructed such that the geometry of the balustrade shall comply with Acceptable Solutions F4/AS1. This includes the following (but not limited to): The minimum barrier height requirement, the maximum gap allowable and the avoidance of non-complying toeholds

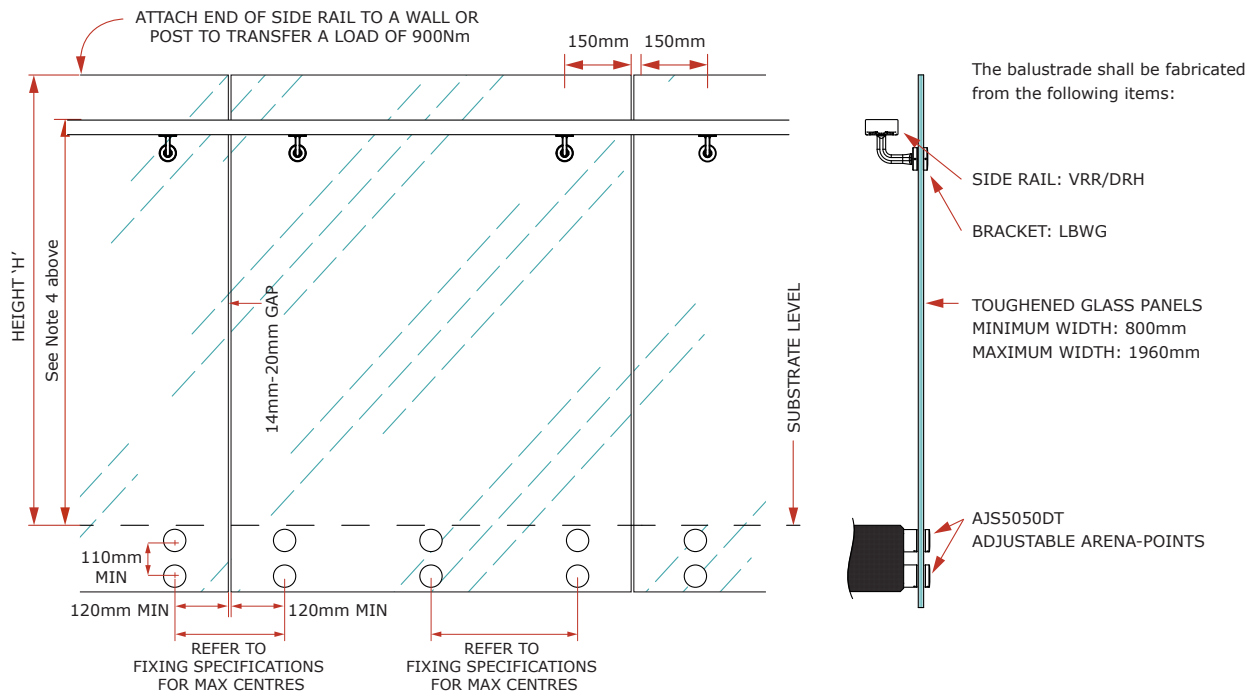

This specification is based on the fixing of the balustrade to the substrate, being as per one of the standard Arena-Points Fixing Specifications in Chapter 3. Refer to the relevant Fixing Specifications in Chapter 3 for minimum glass thickness, and the maximum horizontal spacings allowed for the Arena-Points fittings.

'ARENA-POINTS' (LRR SIDE RAIL)

This is a Style Specification for the Arena Points® Balustrade system. It must only be used in conjunction with a Fixing Specification from pages 120-122, and the Assembly Specification AS.65.12T on Page 173. Installation must be completed in accordance with the Installation Guide on pages 223-225 and all other relevant portions of this manual.

1. Glass shall be GRADE A SAFETY GLASS, TOUGHENED in accordance with AS/NZS 2208, with a minimum thickness as determined from Table below. Glass shall be supported and glazed in accordance with NZS 4223, **and shall be a minimum of 100MPa**. All exposed edges to be flat polished.
2. The side rail shall connect to the glass with LBWG brackets. Each pane of glass shall have at least two of these brackets. The side rail ends shall be structurally attached to a building element to transfer a load of 900 Newtons in any direction. At any joins or corners, the top rail shall be structurally gusseted to transfer a load of 900 Newtons in any direction.
3. A Side Rail is not required on the Frameless Glass styles if not preventing a fall of 1.0m or more.
4. The circular holes in the glass for the Arena-Points shall be 26mm Ø.
5. ***IMPORTANT NOTE*** Side Rail height shall not be less than the minimum barrier height, as required in F4/AS1.
6. The balustrade shall be constructed such that the geometry of the balustrade shall comply with Acceptable Solutions F4/AS1. This includes the following (but not limited to): The minimum barrier height requirement, the maximum gap allowable and the avoidance of non-complying toeholds

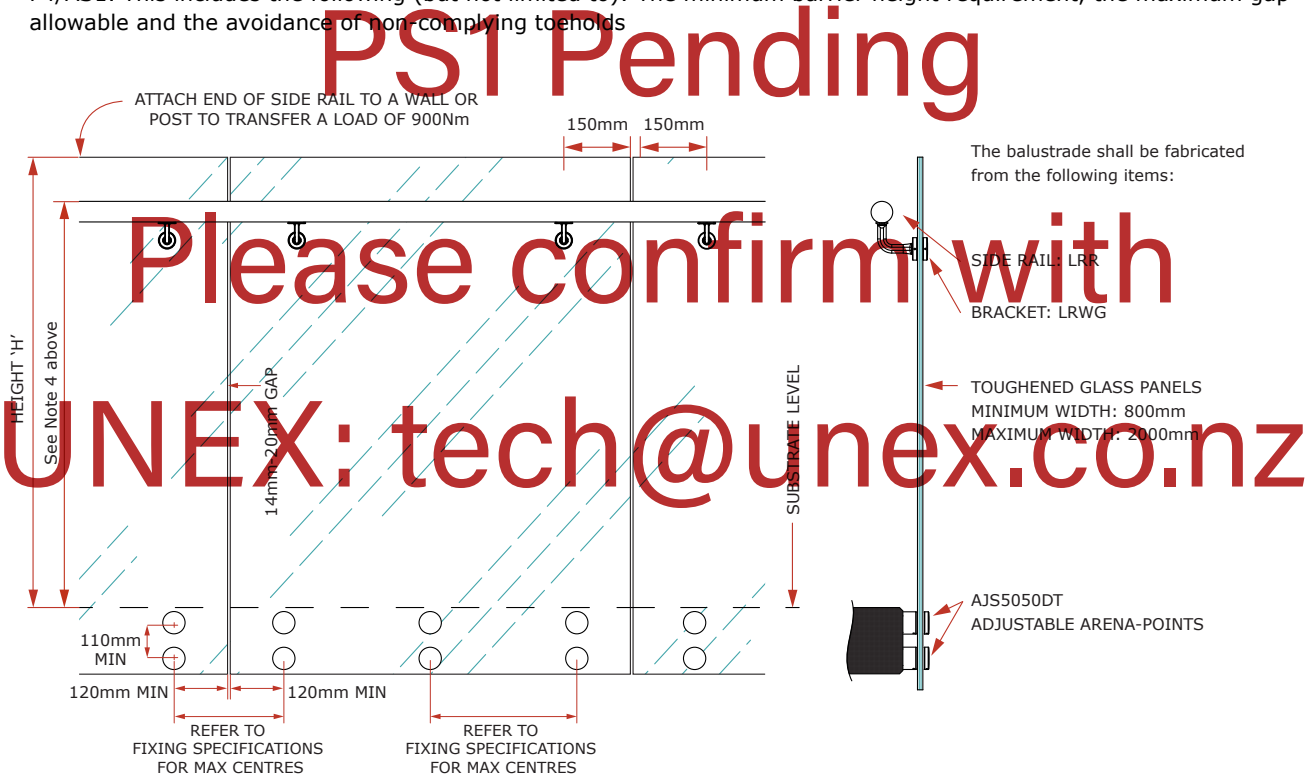

This specification is based on the fixing of the balustrade to the substrate, being as per one of the standard Arena-Points Fixing Specifications in Chapter 3. Refer to the relevant Fixing Specifications in Chapter 3 for minimum glass thickness, and the maximum horizontal spacings allowed for the Arena-Points fittings.

'GLASSTRUT - TOP FIXED' (NO RAIL*)

*Only applicable if NOT preventing a fall of 1.0m or more

This is a Style Specification for the GlasStrut Balustrade system. It must only be used in conjunction with a Fixing Specification from pages 116-119, and the Assembly Specification AS.66.00T on Page 120. Installation must be completed in accordance with the Installation Guide in Chapter 5 and all other relevant portions of this manual.

1. Glass shall be 12mm GRADE A SAFETY GLASS, TOUGHENED in accordance with AS/NZS 2208, with a minimum thickness as determined from Table below. Glass shall be supported and glazed in accordance with NZS 4223, and **shall be a minimum of 100MPa**. All exposed edges to be flat polished.

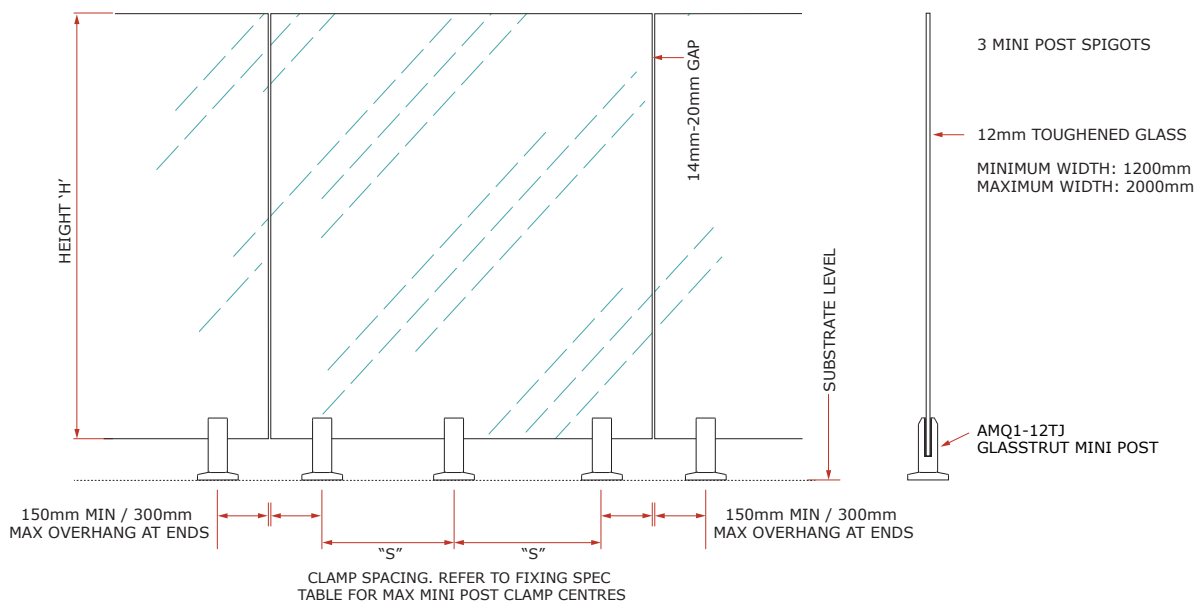
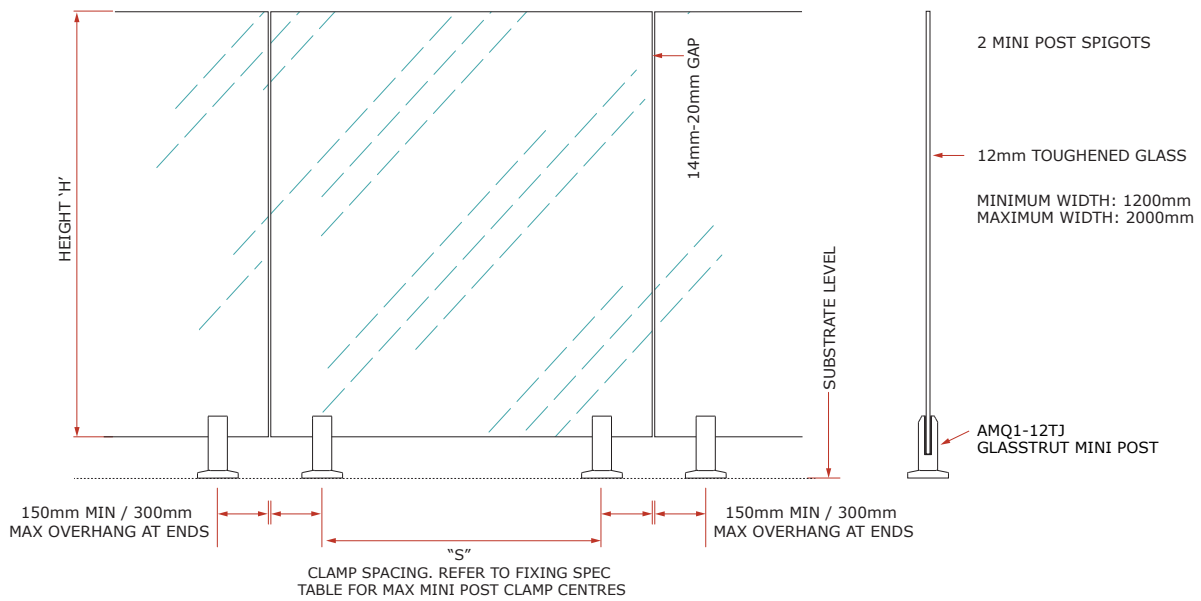

This specification is based on the fixing of the balustrade to the substrate, being as per one of the standard GlasStrut Fixing Specifications in Chapter 3. Refer to the relevant Fixing Specifications in Chapter 3 for minimum glass thickness, and the maximum horizontal spacings allowed for the clamp fittings.

'GLASSTRUT - TOP FIXED' (VRR TOP RAIL)

This is a Style Specification for the GlasStrut Balustrade system. It must only be used in conjunction with a Fixing Specification from pages 96-98, and the Assembly Specification AS.66.12T on Page 121. Installation must be completed in accordance with the Installation Guide in Chapter 5 and all other relevant portions of this manual.

1. Glass shall be **GRADE A SAFETY GLASS, TOUGHENED** in accordance with AS/NZS 2208, with a minimum thickness as determined from Table below. Glass shall be supported and glazed in accordance with NZS 4223, **and shall be a minimum of 100MPa**. All exposed edges to be flat polished.
2. The top rail shall be attached to the top edge of the glass with structural silicone, for the full length of the rail and for the full width of the glass. The top rail ends shall be structurally attached to a building element to transfer a load of 900 Newtons in any direction. At any joins or corners, the top rail shall be structurally gusseted to transfer a load of 900 Newtons in any direction.
3. A Top Rail is not required on the Frameless Glass styles if not preventing a fall of 1.0m or more.

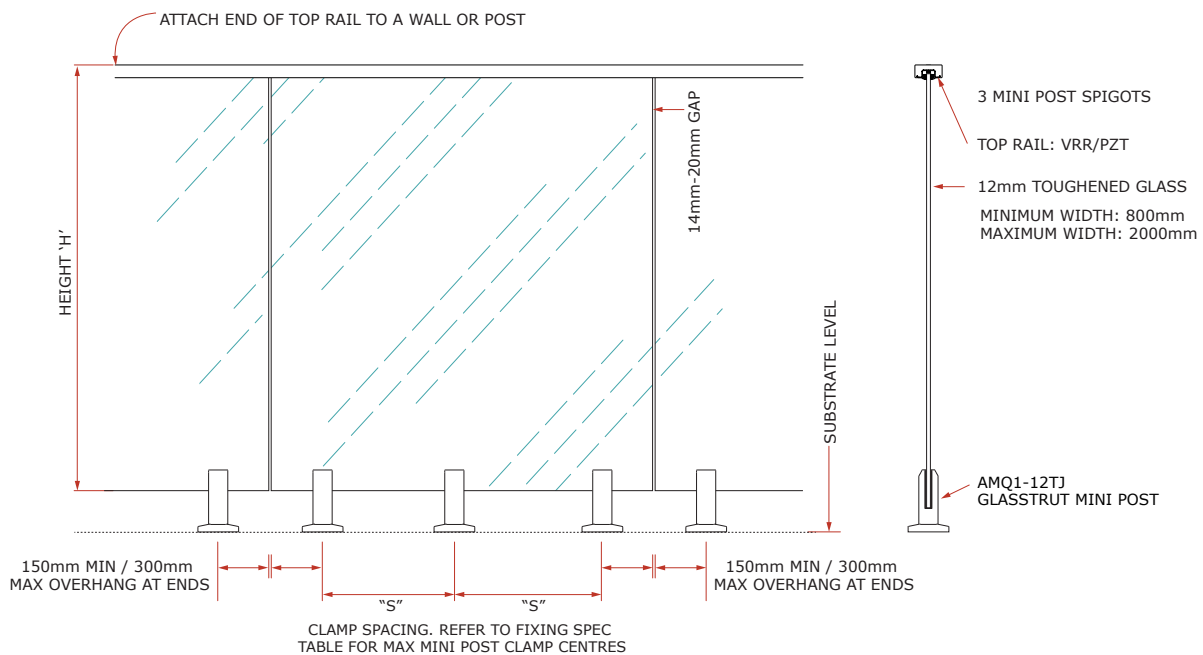
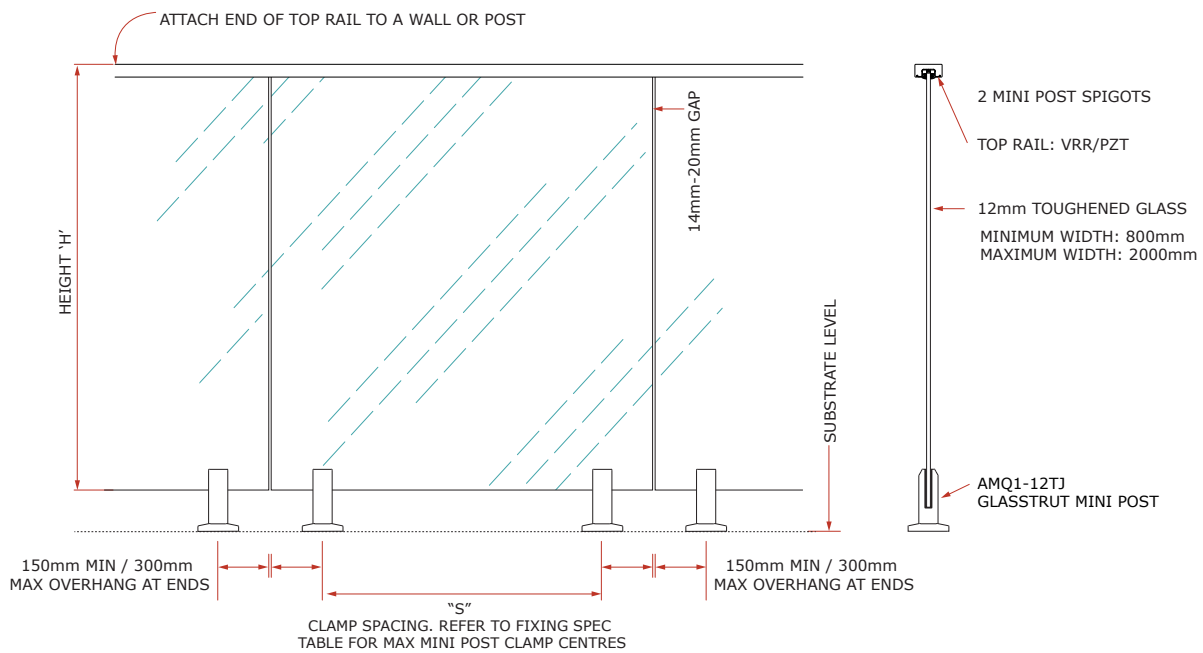

This specification is based on the fixing of the balustrade to the substrate, being as per one of the standard GlasStrut Fixing Specifications in Chapter 3. Refer to the relevant Fixing Specifications in Chapter 3 for minimum glass thickness, and the maximum horizontal spacings allowed for the clamp fittings.

'GLASSTRUT - TOP FIXED' (Q25 STAINLESS STEEL TOP RAIL)

This is a Style Specification for the GlasStrut Balustrade system. It must only be used in conjunction with a Fixing Specification from pages 96-98, and the Assembly Specification AS.61.12T on Page 122. Installation must be completed in accordance with the Installation Guide in Chapter 5 and all other relevant portions of this manual.

1. Glass shall be GRADE A SAFETY GLASS, TOUGHENED in accordance with AS/NZS 2208, with a minimum thickness as determined from Table below. Glass shall be supported and glazed in accordance with NZS 4223, **and shall be a minimum of 100MPa**. All exposed edges to be flat polished.
2. The top rail shall be attached to the top edge of the glass with structural silicone, for the full length of the rail and for the full width of the glass. The top rail ends shall be structurally attached to a building element to transfer a load of 900 Newtons in any direction. At any joins or corners, the top rail shall be structurally gusseted to transfer a load of 900 Newtons in any direction.
3. A Top Rail is not required on the Frameless Glass styles if not preventing a fall of 1.0m or more.

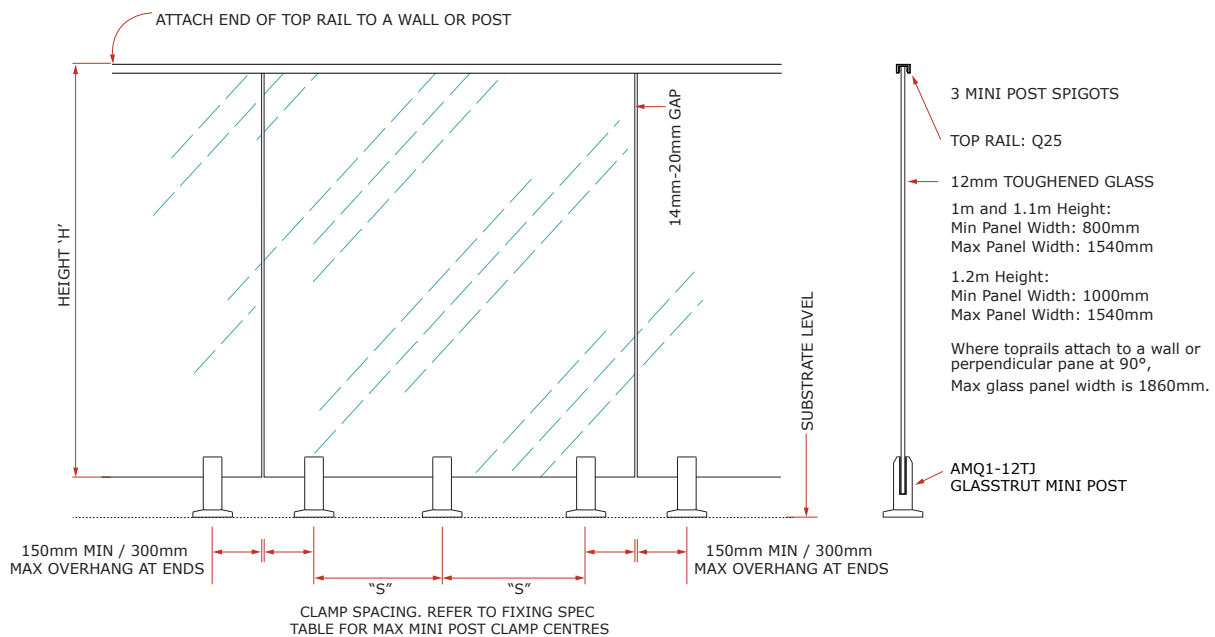
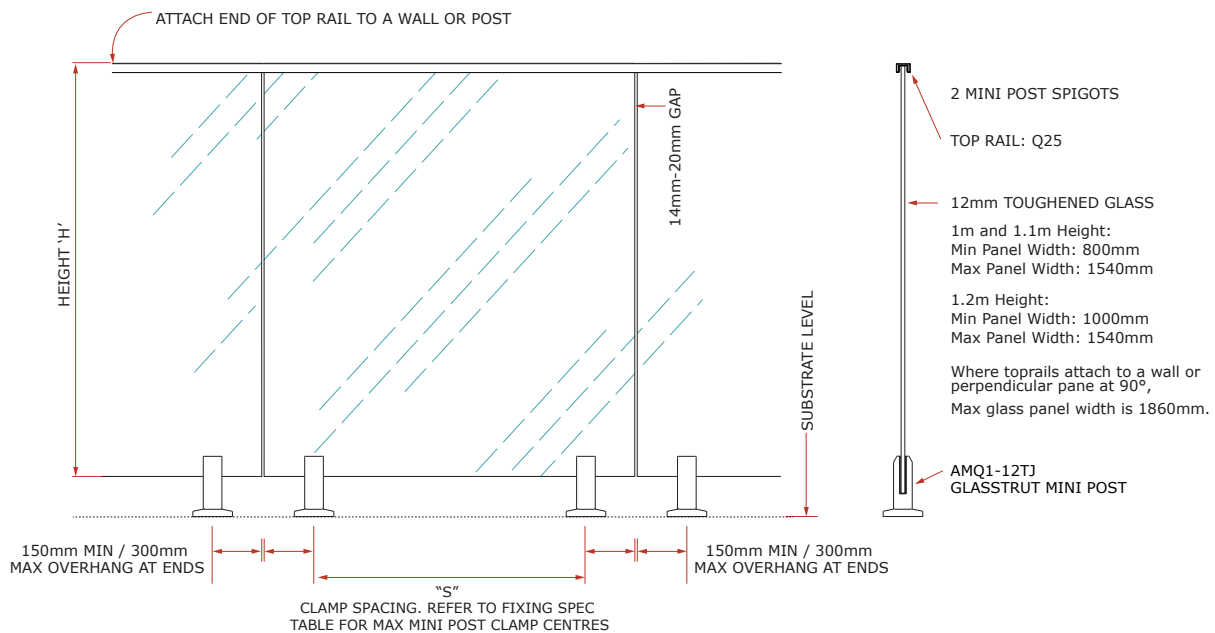

This specification is based on the fixing of the balustrade to the substrate, being as per one of the standard GlasStrut Fixing Specifications in Chapter 3. Refer to the relevant Fixing Specifications in Chapter 3 for minimum glass thickness, and the maximum horizontal spacings allowed for the clamp fittings.

STYLE SPECIFICATIONS

NZBAL-D14.0 | SPEC ID **SS.66.19T**

'GLASSTRUT - TOP FIXED' (Q40 STAINLESS STEEL TOP RAIL)

This is a Style Specification for the GlasStrut Balustrade system. It must only be used in conjunction with a Fixing Specification from pages 96-98, and the Assembly Specification AS.66.19T on Page 123. Installation must be completed in accordance with the Installation Guide in Chapter 5 and all other relevant portions of this manual.

1. Glass shall be **GRADE A SAFETY GLASS, TOUGHENED** in accordance with AS/NZS 2208, with a minimum thickness as determined from Table below. Glass shall be supported and glazed in accordance with NZS 4223, **and shall be a minimum of 100MPa**. All exposed edges to be flat polished.
2. The top rail shall be attached to the top edge of the glass with structural silicone, for the full length of the rail and for the full width of the glass. The top rail ends shall be structurally attached to a building element to transfer a load of 900 Newtons in any direction. At any joins or corners, the top rail shall be structurally gusseted to transfer a load of 900 Newtons in any direction.
3. A Top Rail is not required on the Frameless Glass styles if not preventing a fall of 1.0m or more.

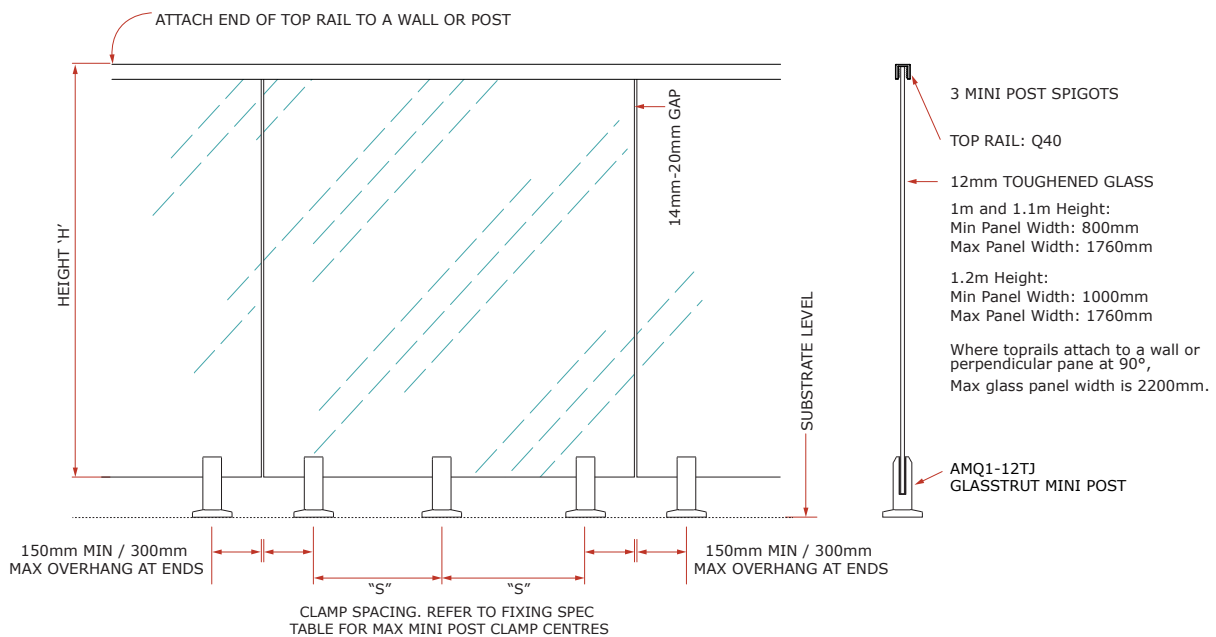
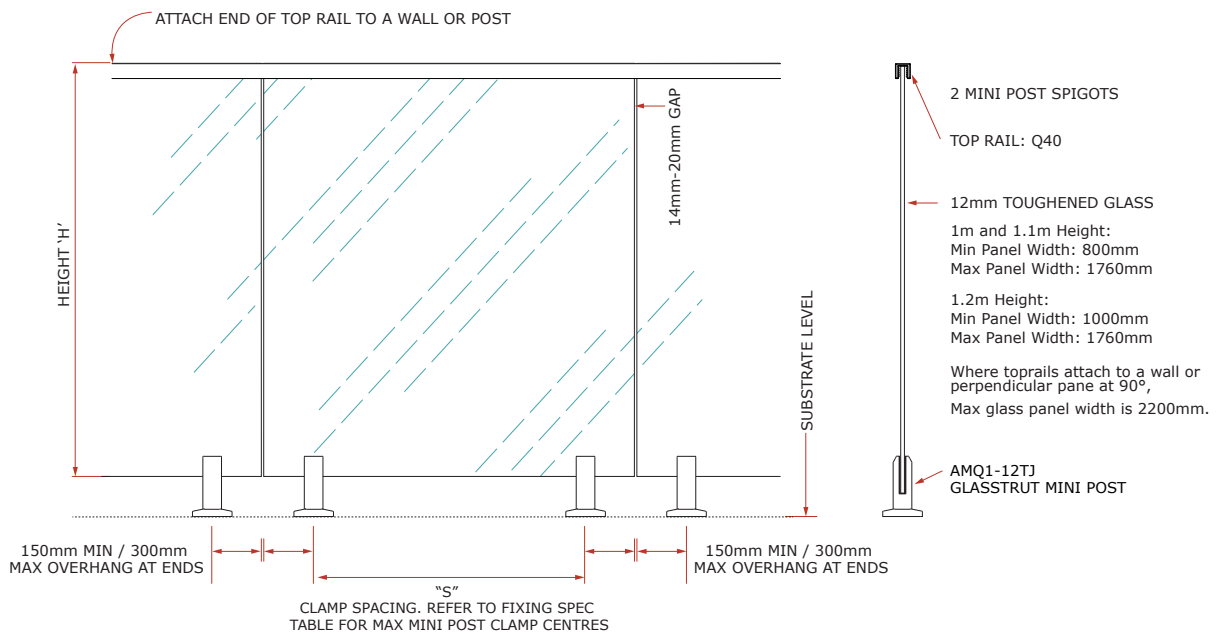

This specification is based on the fixing of the balustrade to the substrate, being as per one of the standard GlasStrut Fixing Specifications in Chapter 3. Refer to the relevant Fixing Specifications in Chapter 3 for minimum glass thickness, and the maximum horizontal spacings allowed for the clamp fittings.

Specifications subject to change without notice

'GLASSTRUT - SIDE FIXED' (NO RAIL)

*Only applicable if NOT preventing a fall of 1.0m or more

This is a Style Specification for the GlasStrut Balustrade system. It must only be used in conjunction with a Fixing Specification from pages 99-101, and the Assembly Specification AS.67.00S on Page 124. Installation must be completed in accordance with the Installation Guide in Chapter 5 and all other relevant portions of this manual.

1. Glass shall be 12mm GRADE A SAFETY GLASS, TOUGHENED in accordance with AS/NZS 2208, with a minimum thickness as determined from Table below. Glass shall be supported and glazed in accordance with NZS 4223, and shall be a minimum of 100MPa. All exposed edges to be flat polished.

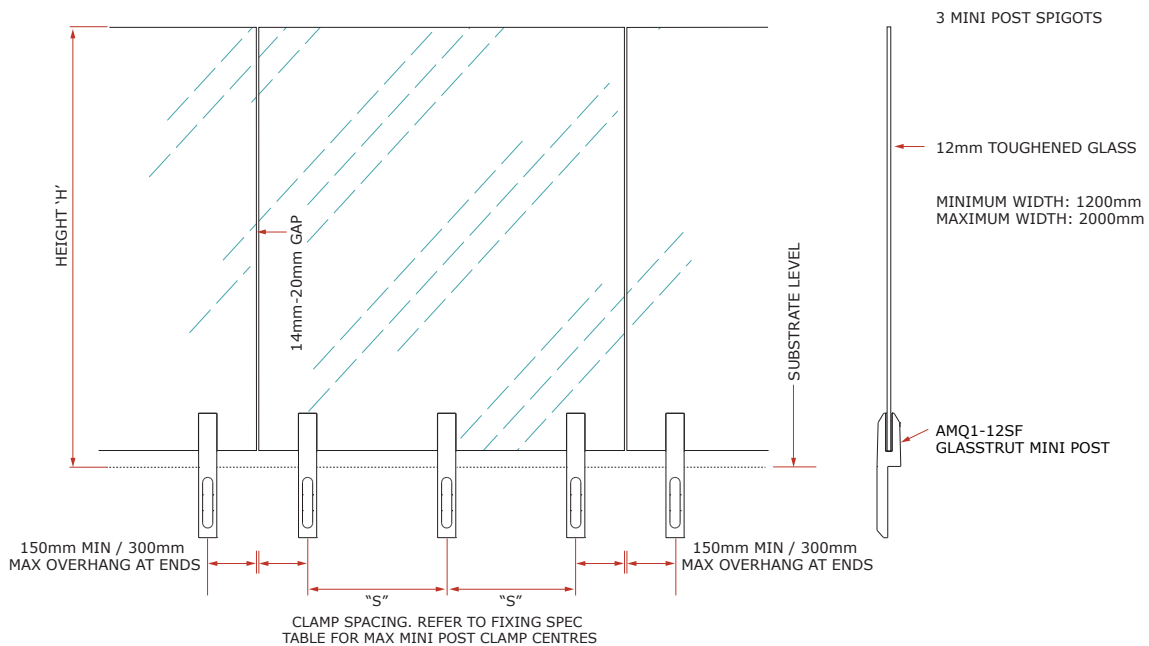
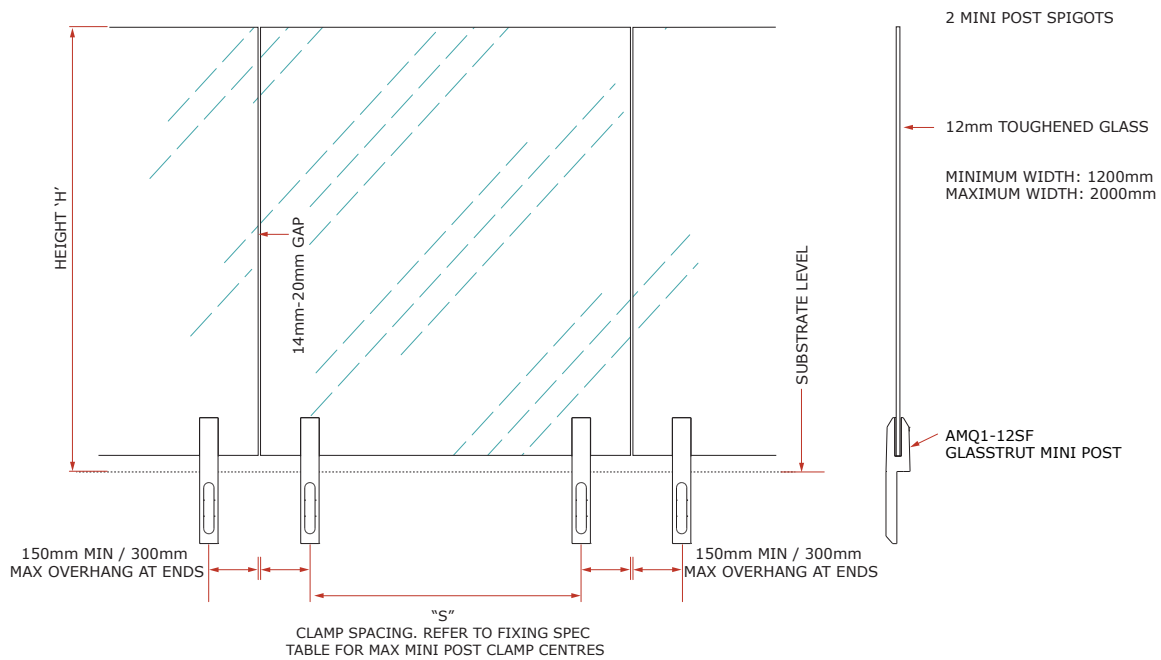

This specification is based on the fixing of the balustrade to the substrate, being as per one of the standard GlasStrut Fixing Specifications in Chapter 3. Refer to the relevant Fixing Specifications in Chapter 3 for minimum glass thickness, and the maximum horizontal spacings allowed for the clamp fittings.

STYLE SPECIFICATIONS

NZBAL-D14.0 | SPEC ID **SS.67.12S**

'GLASSTRUT - SIDE FIXED' (VRR TOP RAIL)

This is a Style Specification for the GlasStrut Balustrade system. It must only be used in conjunction with a Fixing Specification from pages 99-101, and the Assembly Specification AS.67.12S on Page 125. Installation must be completed in accordance with the Installation Guide in Chapter 5 and all other relevant portions of this manual.

1. Glass shall be **GRADE A SAFETY GLASS, TOUGHENED** in accordance with AS/NZS 2208, with a minimum thickness as determined from Table below. Glass shall be supported and glazed in accordance with NZS 4223, **and shall be a minimum of 100MPa**. All exposed edges to be flat polished.
2. The top rail shall be attached to the top edge of the glass with structural silicone, for the full length of the rail and for the full width of the glass. The top rail ends shall be structurally attached to a building element to transfer a load of 900 Newtons in any direction. At any joins or corners, the top rail shall be structurally gusseted to transfer a load of 900 Newtons in any direction.
3. A Top Rail is not required on the Frameless Glass styles if not preventing a fall of 1.0m or more.

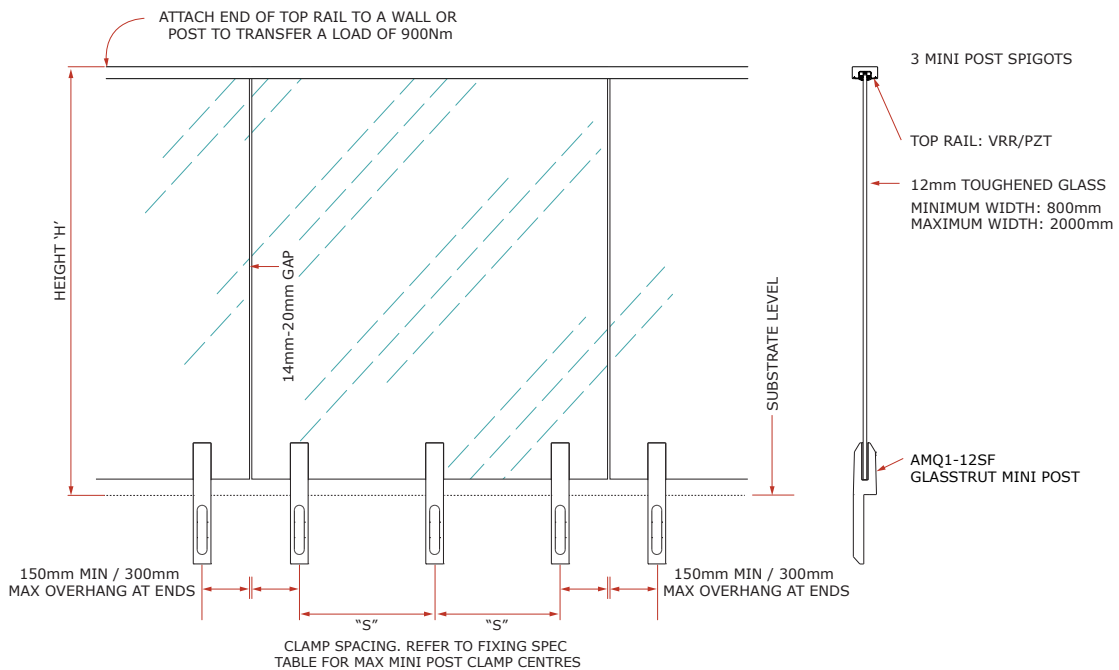
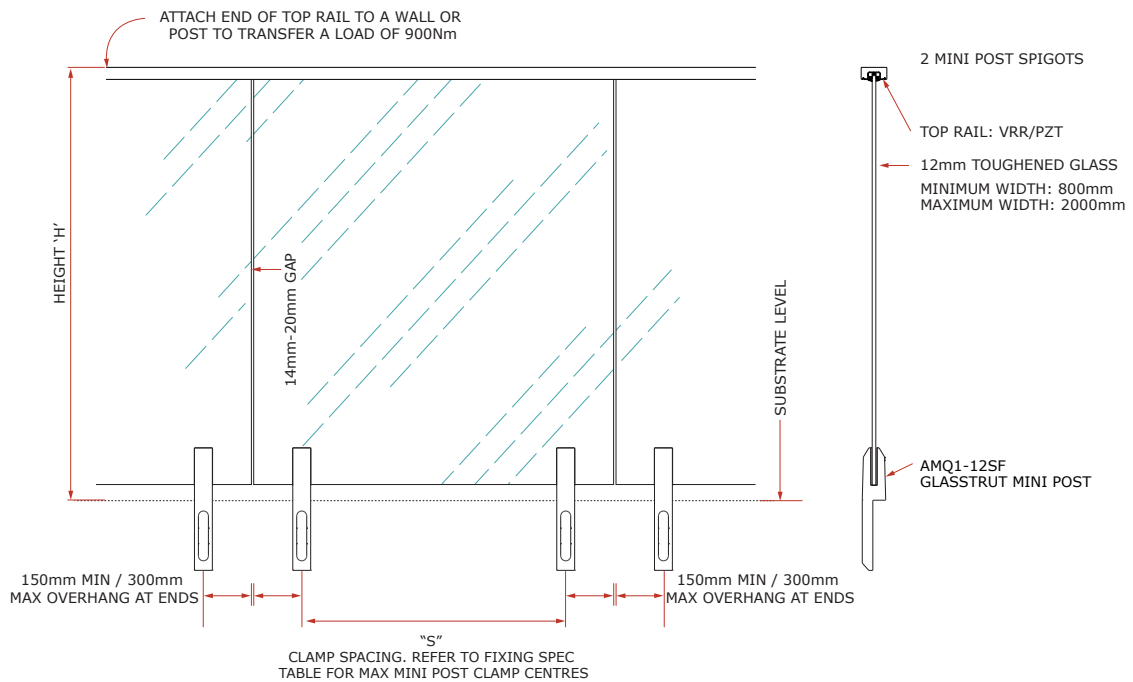

This specification is based on the fixing of the balustrade to the substrate, being as per one of the standard GlasStrut Fixing Specifications in Chapter 3. Refer to the relevant Fixing Specifications in Chapter 3 for minimum glass thickness, and the maximum horizontal spacings allowed for the clamp fittings.

Specifications subject to change without notice

'GLASSTRUT - SIDE FIXED' (Q25 STAINLESS STEEL TOP RAIL)

This is a Style Specification for the GlasStrut Balustrade system. It must only be used in conjunction with a Fixing Specification from pages 99-101, and the Assembly Specification AS.67.18S on Page 126. Installation must be completed in accordance with the Installation Guide in Chapter 5 and all other relevant portions of this manual.

1. Glass shall be **GRADE A SAFETY GLASS, TOUGHENED** in accordance with AS/NZS 2208, with a minimum thickness as determined from Table below. Glass shall be supported and glazed in accordance with NZS 4223, **and shall be a minimum of 100MPa**. All exposed edges to be flat polished.
2. The top rail shall be attached to the top edge of the glass with structural silicone, for the full length of the rail and for the full width of the glass. The top rail ends shall be structurally attached to a building element to transfer a load of 900 Newtons in any direction. At any joins or corners, the top rail shall be structurally gusseted to transfer a load of 900 Newtons in any direction.
3. A Top Rail is not required on the Frameless Glass styles if not preventing a fall of 1.0m or more.

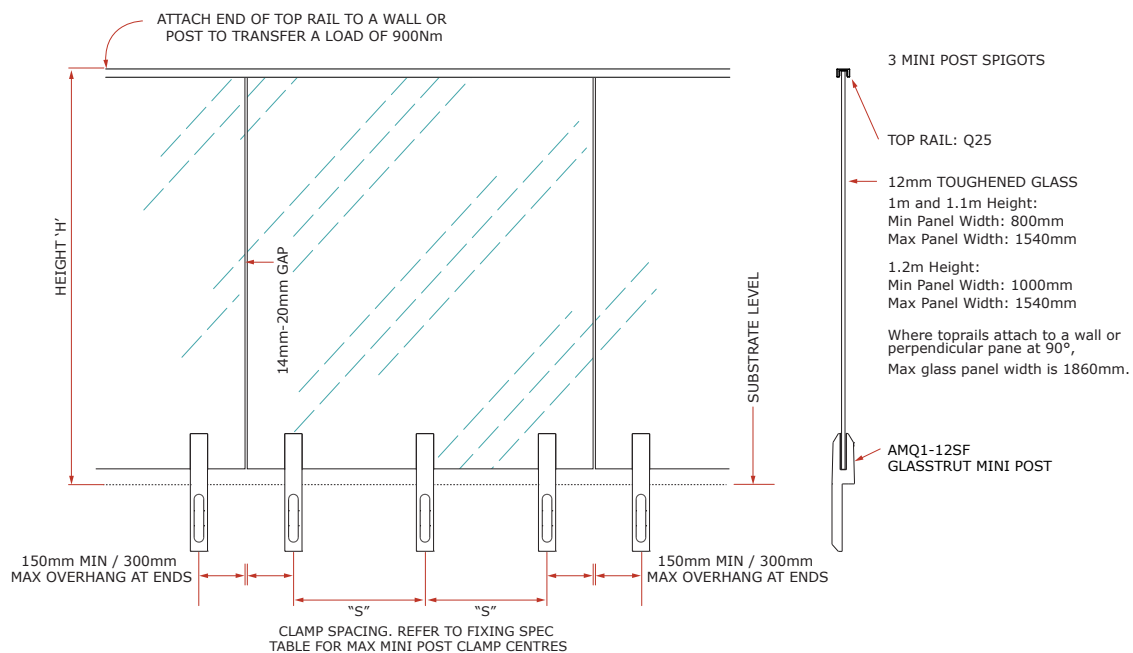
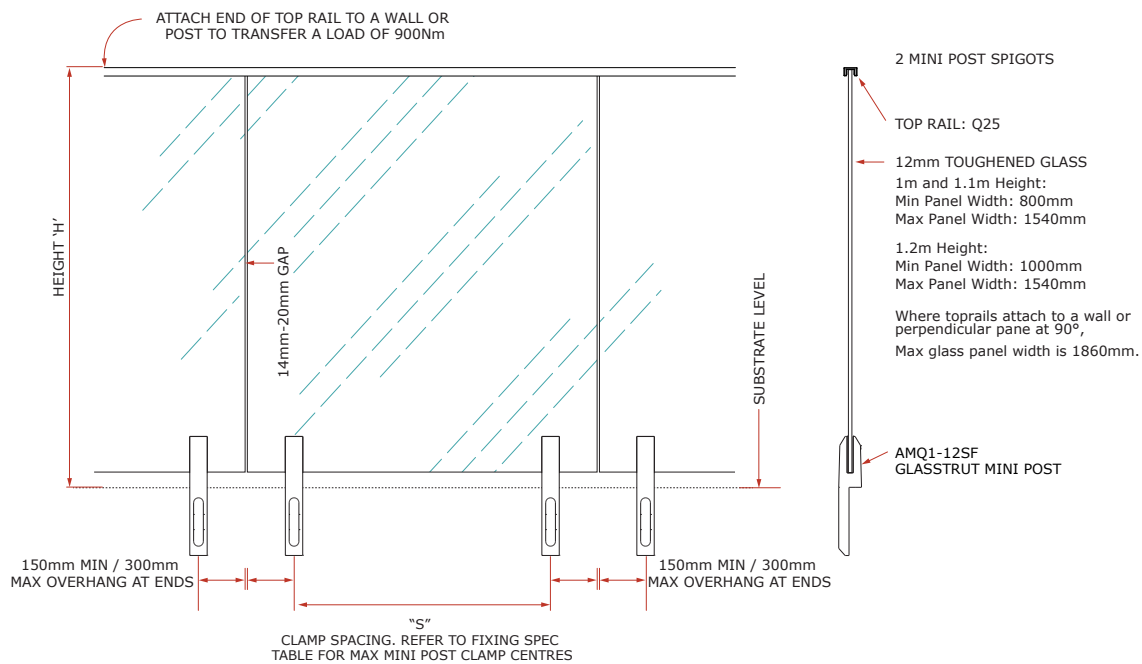

This specification is based on the fixing of the balustrade to the substrate, being as per one of the standard GlasStrut Fixing Specifications in Chapter 3. Refer to the relevant Fixing Specifications in Chapter 3 for minimum glass thickness, and the maximum horizontal spacings allowed for the clamp fittings.

STYLE SPECIFICATIONS

NZBAL-D14.0 | SPEC ID **SS.67.19S**

'GLASSTRUT - SIDE FIXED' (Q40 STAINLESS STEEL TOP RAIL)

This is a Style Specification for the GlasStrut Balustrade system. It must only be used in conjunction with a Fixing Specification from pages 99-101, and the Assembly Specification AS.67.19S on Page 127. Installation must be completed in accordance with the Installation Guide in Chapter 5 and all other relevant portions of this manual.

1. Glass shall be **GRADE A SAFETY GLASS, TOUGHENED** in accordance with AS/NZS 2208, with a minimum thickness as determined from Table below. Glass shall be supported and glazed in accordance with NZS 4223, **and shall be a minimum of 100MPa**. All exposed edges to be flat polished.
2. The top rail shall be attached to the top edge of the glass with structural silicone, for the full length of the rail and for the full width of the glass. The top rail ends shall be structurally attached to a building element to transfer a load of 900 Newtons in any direction. At any joins or corners, the top rail shall be structurally gusseted to transfer a load of 900 Newtons in any direction.
3. A Top Rail is not required on the Frameless Glass styles if not preventing a fall of 1.0m or more.

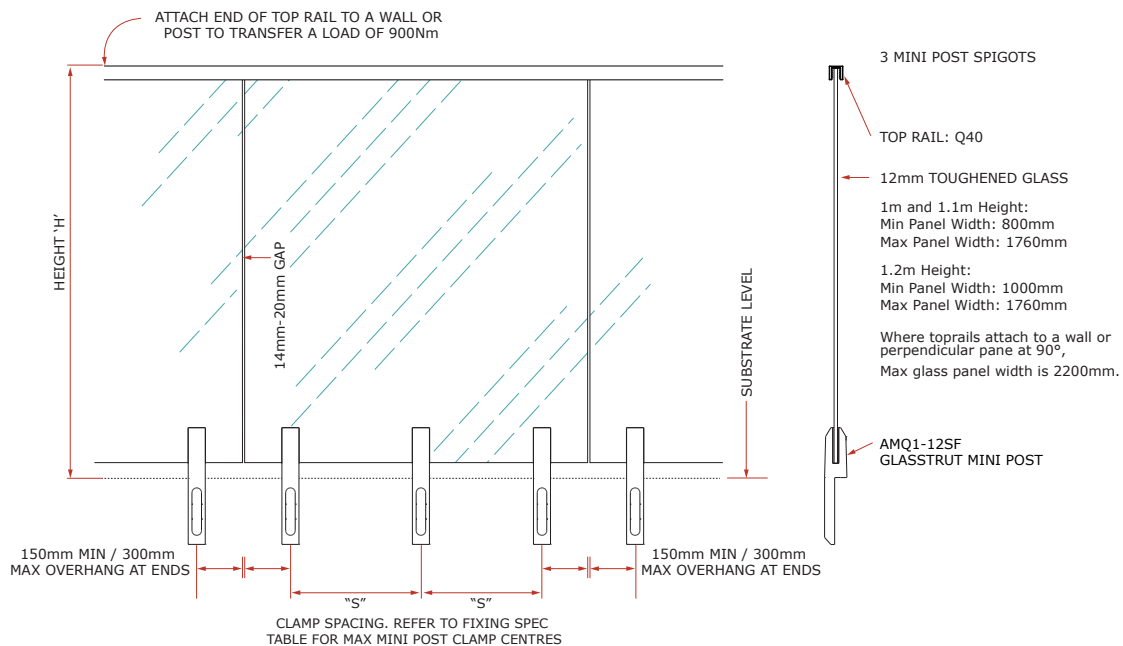
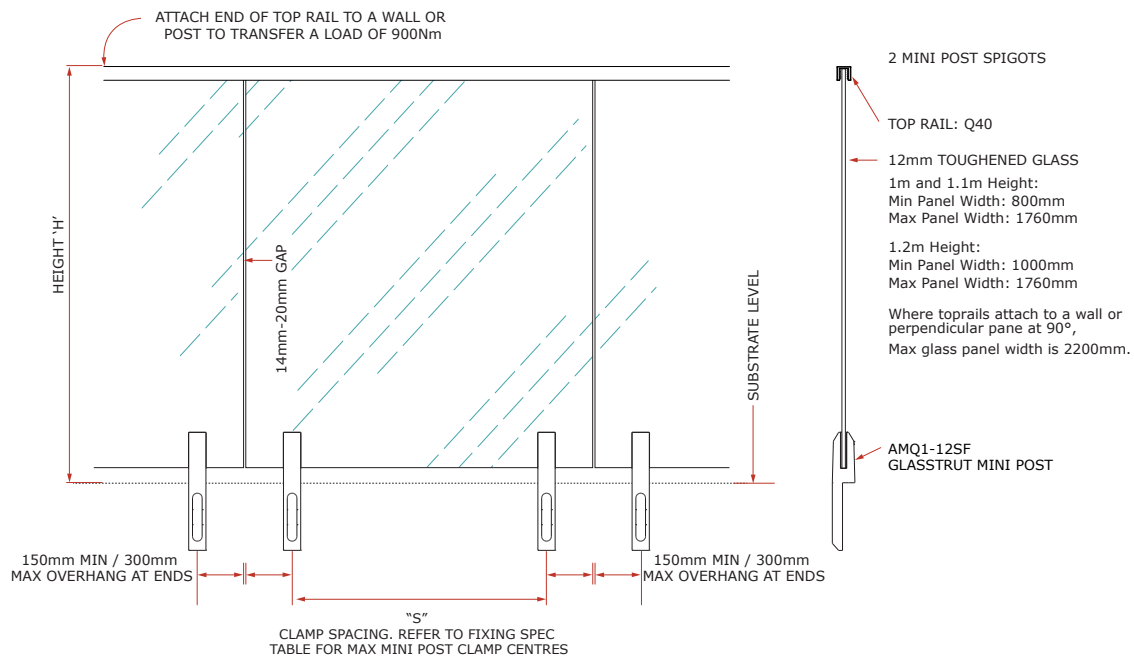

This specification is based on the fixing of the balustrade to the substrate, being as per one of the standard GlasStrut Fixing Specifications in Chapter 3. Refer to the relevant Fixing Specifications in Chapter 3 for minimum glass thickness, and the maximum horizontal spacings allowed for the clamp fittings.

Specifications subject to change without notice

CHAPTER 3 - FRAMELESS GLASS FIXING SPECIFICATIONS

General Notes for Fixing to Timber Substrates	78-79
General Notes for Fixing to Concrete and Masonry Substrates	80-81
General Notes for Fixing to Steel Substrates.....	82

SPEC ID	FIXING METHOD	
FS.1T.05.60	'Metropolis' - Dry Timber, 135mm Edge Joist, Screws	83
FS.1T.22.60	'Metropolis' - Dry Timber, LVL Beam, Screws	84
FS.2T.22.60	'Metropolis' - Wet Timber, 90mm Joist, Screws	85
FS.2T.05.60	'Metropolis' - Wet Timber, 135mm Joist, Screws	86
FS.3T.05.60	'Metropolis' - Concrete	87
FS.5T.22.60	'Metropolis' - Steel	88
FS.1S.04.61	'Panorama' - Dry Timber, 90mm Joist.....	89
FS.2S.05.61	'Panorama' - Wet Timber, 135mm Joist.....	90
FS.3S.19.61	'Panorama' - Concrete, Central Epoxy Anchors	91
FS.5S.06.61	'Panorama' - Steel PFC, Central Fixing Bolts.....	92
FS.1S.04.65	'Arena-Points' - Standard Timber Fixing	93
FS.3S.19.65	'Arena-Points' - Standard Concrete Fixing	94
FS.5S.06.65	'Arena-Points' - Standard Steel PFC Fixing	95
FS.2T.02.66	'GlasStrut Top Fixed' - Wet Timber Fixing.....	96
FS.3T.02.66	'GlasStrut Top Fixed' - Concrete Fixing	97
FS.5T.02.66	'GlasStrut Top Fixed' - Steel Fixing.....	98
FS.2S.05.67	'GlasStrut Side Fixed' - Wet Timber Fixing	99
FS.3S.02.67	'GlasStrut Side Fixed' - Concrete Fixing	100
FS.5S.02.67	'GlasStrut Side Fixed' - Steel Fixing	101

GENERAL NOTES FOR FIXING TO TIMBER SUBSTRATES

The following notes refer to construction details for Top Fixing and Side Fixing channel systems to timber structures.

1. GENERAL

Tables in Chapter 2 (Style Specifications) gives the glass type, thickness and the maximum clamp assembly centres permitted, with or without a Top Rail, as a system. (Except for the Arena-Points refer to the tables in the Chapter 3 Fixing Specification pages).

Fixing Specifications in Chapter 3 indicate the fixing type and quantity of substrate fasteners within each clamp assembly unit. The clamp assembly unit centres are determined by the Style Specifications.

2. LOADING CLASS

Refer to Page 175 for a description of the various Loading Class designations.

3. APPROVED FASTENERS

All fasteners shall be manufactured from 316 stainless steel and be supplied by UNEX.

Coach screws shall be manufactured to DIN 571 and are identified in the tables by their part number. e.g. FCP8-165 : FC = Coach screw stainless steel ; 8 = 8mm diameter ; 165 = length in mm.

Bolts shall be Class 70 stainless steel and be fitted with stainless steel nyloc nuts and washers. Alternatively use 316 S/S threaded rods with nuts and washers. Use S/S dome nuts in lieu of standard nut heads where visible. All washers must be 50mm square stainless steel when bearing against timber structures.

4. HEIGHT

Height 'H' is the overall height of the balustrade above the substrate level shown. Interpolate for heights between those shown.

5. DESIGN WIND SPEED

Design Wind Speeds are ultimate limit state wind speeds. Guidance on how this may be determined for any site is given on Pages 48-49. M, H, VH, and EH indicate Medium, High, Very High, and Extremely High Wind Zones from NZS 3604:2011. Interpolate between wind speeds shown. For Loading Class N07C/N07R and N03R refer to AS/NZS 1170 for determining Wind Speeds.

6. FABRICATION AND INSTALLATION

Fabrication and Installation are to be in accordance with Section 5 of this Manual and where applicable, comply with the relevant requirements of the NZ Building Code.

7. SUBSTRATE DESIGN

Substrate Design including waterproofing and structural design of the timber members and their connections is beyond the scope of these specifications and must be carried out by others. Structural timber shall have a minimum thickness of 45mm.

8. TIMBER

Screw strength is based on structural timber being Pinus Radiata VSG8 or MSG8, or higher.

DRY TIMBER is timber with a maximum in-service moisture content of 18%.

WET TIMBER is timber where the in-service moisture content could be greater than 18% eg. exposed decks.

(continued on following Page)

Specifications subject to change without notice

GENERAL NOTES FOR FIXING TO TIMBER SUBSTRATES - (CONT'D)

9. INSERTING COACH SCREWS

For 8mm and 10mm coach screws, pre-drill the entire screw embedment to the following diameters.

5.5mm diameter for 8mm coach screws. (TDT5.5 Drill bits available from UNEX).

8mm diameter for 10mm coach screws. (TDT8.0 Drill bits available from UNEX).

Where the unthreaded shaft of the screw will penetrate the structural timber, it will also be necessary to predrill the depth of the hole that will be occupied by the unthreaded shank to the nominal shank diameter taking great care not to extend this drilling into the threaded portion.

In some situations, the screws may penetrate beyond the structural timber. Check for suitability.

10. DURABILITY

Instructions relating to durability issues outlined on Pages 165-166 of this manual must be carried out in conjunction with these Fixing Specifications. These instructions cover a number of areas including; post drainage slots and separation of the aluminium from the stainless steel fasteners and/or the substrate. Detailed instructions are given throughout this manual, particularly in Chapter 5.

11. PACKING CAVITIES

For side fixed posts or channels, the full area between the post or channel and the supporting substrate must be packed solid with No 1 Pinus Radiata or material having an equivalent bearing strength.

12. DEFLECTION

Please note that some of the following fixing specifications may exceed the non-mandatory recommended balustrade deflection guide, refer to page 45 for more information.

13. SUBSTRATE FASTENER BONDING

Where required all substrate coach screws, must have fully engaged threads to structural wet timber and be embedded with **"Sika Supergrip 2 Hour"** Adhesive. The adhesive is available from UNEX code: #TASG and must not be substituted with other adhesives. Insert some adhesive into the pre-drilled hole and liberally apply to the coach screws before insertion. Ensure you always follow all the manufacturers safety procedures and usage instructions.

GENERAL NOTES FOR FIXING TO CONCRETE & MASONRY SUBSTRATES

The following notes refer to specifications for Top Fixing and Side Fixing channels to Concrete and Masonry substrates.

1. GENERAL

Tables in Chapter 2 (Style Specifications) gives the glass type, thickness and the maximum clamp assembly centres permitted, with or without a Top Rail, as a system. (Except for the Arena-Points refer to the tables in the Chapter 3 Fixing Specification pages).

Fixing Specifications in Chapter 3 indicate the fixing type and quantity of substrate fasteners within each clamp assembly unit. The clamp assembly unit centres are determined by the Style Specifications.

2. LOADING CLASS

Refer to Page 175 for a description of the various Loading Class designations.

3. FASTENERS

Fasteners shall be manufactured from 316 stainless steel and be supplied by UNEX. They are identified in the tables by their UNEX Part Number. Refer to Chapter 1 eg. FE12-140 (AZM2) or FE12-150 (AZS3): FE = Threaded Stud Stainless Steel; 12 = 12mm diameter; 140 = length in mm.

All studs shall be threaded 316 stainless steel (S/S) with an ultimate tensile stress of not less than 560 MPa and all bolts shall be strength Class 70 with an ultimate tensile stress of not less than 700 MPa.

4. HEIGHT

Height 'H' is the overall height of the balustrade above the substrate level shown. Interpolate for heights between those shown.

5. DESIGN WIND SPEED

Design Wind Speeds are ultimate limit state wind speeds. Guidance on how this may be determined for any site is given on Pages 48-49. M, H, VH, and EH indicate Medium, High, Very High, and Extremely High Wind Zones from NZS 3604:2011. Interpolate between wind speeds shown. For Loading Class N07C/N07R and N03R refer to AS/NZS 1170 for determining Wind Speeds.

6. EPOXY ANCHORING

FE studs as described in Note 3 above, shall be installed and anchored into concrete using the Epoxy C6 Plus system in accordance with the manufacturer's instructions. Refer to page 167 for further details of these instructions.

7. FABRICATION & INSTALLATION

Fabrication and Installation are to be in accordance with Section 5 of this Manual and where applicable, comply with the relevant requirements of the NZ Building Code.

8. SUBSTRATE DESIGN

Substrate Design including waterproofing and structural design of the concrete and masonry supporting substrate including reinforcement is beyond the scope of this specification and must be carried out by others.

9. CONCRETE

Concrete shall have a minimum 28 day crushing strength of 20MPa.

(continued on following Page)

Specifications subject to change without notice

GENERAL NOTES FOR FIXING TO CONCRETE & MASONRY SUBSTRATES (CONT.)

10. CONCRETE MASONRY

Masonry units shall comply with AS/NZS 4455 with a typical concrete strength of 12 MPa. All masonry units supporting balustrades shall be filled completely with 20MPa concrete infill and be adequately reinforced to resist the balustrade loads.

All fixing must be anchored into the infill concrete for the depths shown. Fixings that pass partly through the web of the masonry unit must pass right through the masonry unit and be anchored with a 50 x 50 x 3mm S/S washer and nut on the far side.

Top fixing is not allowed on walls less than 190mm wide.

Concrete specification DO NOT apply to AAC (Autoclaved Aerated Concrete) cladding panels. Contact UNEX for a Site-Specific PS1 in this instance.

GENERAL NOTES FOR FIXING TO STEEL SUBSTRATES

The following notes refer to specifications for Top Fixing and Side Fixing channels to Steel substrates.

1. GENERAL

Tables in Chapter 2 (Style Specifications) gives the glass type, thickness and the maximum clamp assembly centres permitted, with or without a Top Rail, as a system. (Except for the Arena-Points refer to the tables in the Chapter 3 Fixing Specification pages).

Fixing Specifications in Chapter 3 indicate the fixing type and quantity of substrate fasteners within each clamp assembly unit. The clamp assembly unit centres are determined by the Style Specifications.

2. LOADING CLASS

Refer to Page 175 for a description of the various Loading Class designations.

3. FASTENERS

Fasteners shall be manufactured from 316 stainless steel and be supplied by UNEX. They are identified in the drawings by their UNEX Part Number. Refer to Chapter 1 further, eg. FB12-50 (AZM2) or FB12-40 (AZS3): FB = Threaded Bolt Stainless Steel; 12 = 12mm diameter; 50 = length in mm.

All bolts shall be 316 stainless steel (S/S), strength Class 70, with an ultimate tensile stress of not less than 700 MPa.

4. HEIGHT

Height 'H' is the overall height of the balustrade above the substrate level shown. Interpolate for heights between those shown.

5. DESIGN WIND SPEED

Design Wind Speeds are ultimate limit state wind speeds. Guidance on how this may be determined for any site is given on Pages 48-49. M, H, VH, and EH indicate Medium, High, Very High, and Extremely High Wind Zones from NZS 3604:2011. Interpolate between wind speeds shown. For Loading Class N07C/N07R and N03R refer to AS/NZS 1170 for determining Wind Speeds.

6. FABRICATION AND INSTALLATION

Fabrication and Installation are to be in accordance with Section 5 of this Manual and where applicable, comply with the relevant requirements of the NZ Building Code.

7. SUBSTRATE DESIGN

Substrate Design including waterproofing and structural design of the steel supporting substrate including reinforcement is beyond the scope of this specification and must be carried out by others.

8. STEEL

Any holes drilled into steel shall have a protective coating applied to prevent corrosion. Consult a specialist for advice on the type of coating required.

Any and all aluminium shall be separated from steel using TSS90 tape, or neoprene gaskets, for the entire area in contact.

'METROPOLIS' - DRY TIMBER, 135MM EDGE JOIST, SCREWS

This is a Standard Fixing Specification for the 'Metropolis' Styles to the timber substrates using the AZM2 channel. It must only be used in conjunction with the relevant Style Specifications in Chapter 2. Installation must be completed in accordance with the Installation Guide in Chapter 5 and all other relevant portions of this manual.

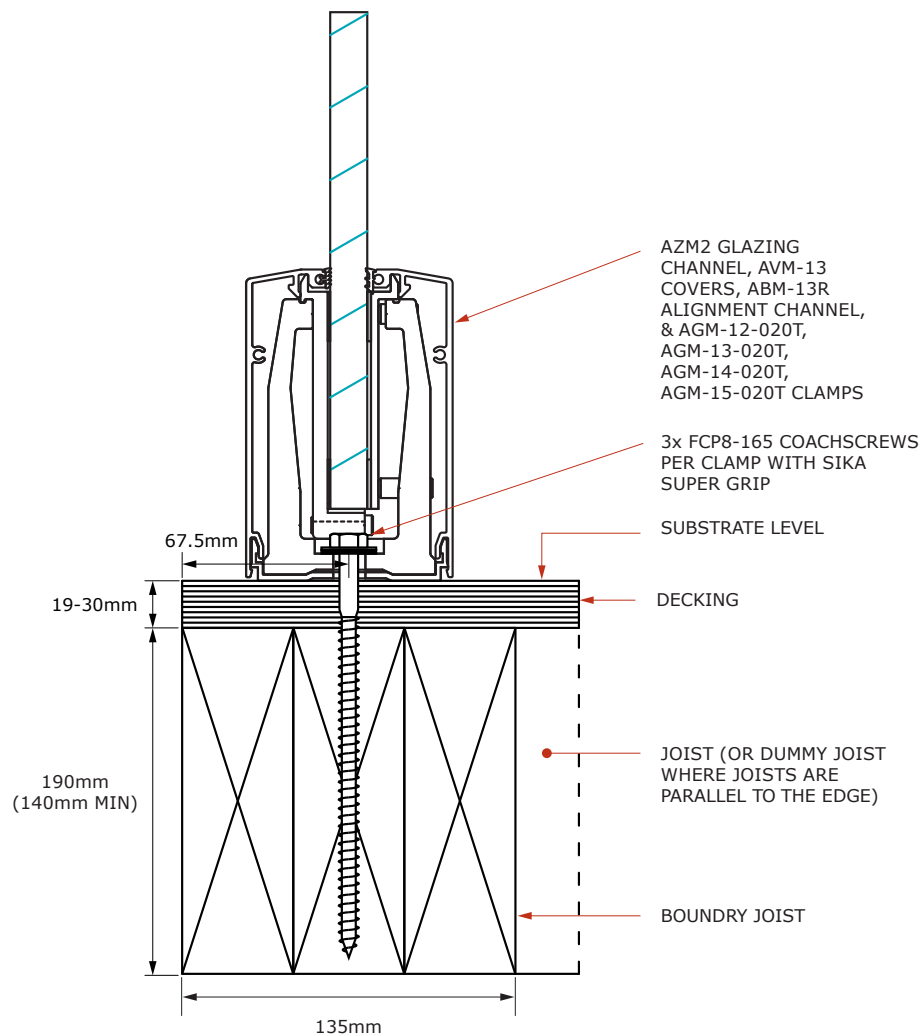

NOTES RELATING TO THIS SPECIFICATION

1. Structural timber must be Pinus Radiata VSG8 or MSG8, or higher, see General Notes on Page 78.
2. For details of fasteners refer to General Notes on Page 78 note 3. Fasteners shall be positioned on the center groove line.
3. Washers to be fitted under coachscrews shall be stainless steel & polymer washers.
4. A level and uniform surface must be provided beneath the Glazing Channel. The Glazing Channel is not recommended to be installed over tiles.
5. Fabrication and Installation are to be in accordance with the relevant requirements of the Assembly Specifications in Chapter 4, the Installation Guides in Chapter 5, and other applicable portions of this Frameless Glass Manual.
6. Substrate design including waterproofing and the structural design of the timber substrate and its connections are not included in this specification and must be carried out by others.
7. The 3x coachscrews illustrated may be replaced with 2x M8 threaded rod extending and bolting right through the joists. Washer to be stainless steel & EPDM with FN8 nut on top, 50mm square stainless steel washers, stainless steel washers, and nyloc nut (FN8N) on the underside.

FIXING SPECIFICATIONS

NZBAL-D13.1 | SPEC ID **FS.1T.22.60**

'METROPOLIS' - DRY TIMBER, LVL BEAM, SCREWS

This is a Standard Fixing Specification for the 'Metropolis' Styles to the timber substrates using the AZM2 channel. It must only be used in conjunction with the relevant Style Specifications in Chapter 2. Installation must be completed in accordance with the Installation Guide in Chapter 5 and all other relevant portions of this manual.

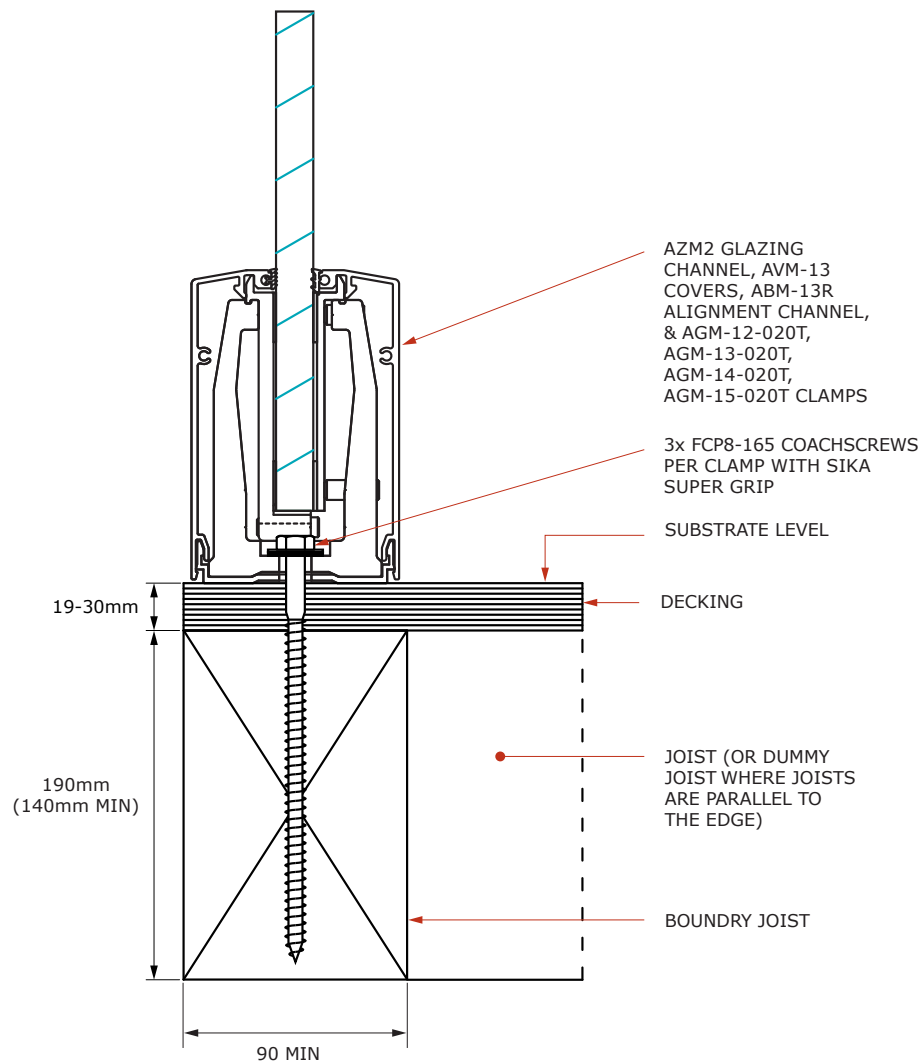

NOTES RELATING TO THIS SPECIFICATION

1. Structural timber must be Pinus Radiata VSG8 or MSG8, or higher, see General Notes on Page 78.
2. For details of fasteners refer to General Notes on Page 78 note 3. Fasteners shall be positioned on the center groove line.
3. Washers to be fitted under coachscrews shall be stainless steel & polymer washers.
4. A level and uniform surface must be provided beneath the Glazing Channel. The Glazing Channel is not recommended to be installed over tiles.
5. Fabrication and Installation are to be in accordance with the relevant requirements of the Assembly Specifications in Chapter 4, the Installation Guides in Chapter 5, and other applicable portions of this Frameless Glass Manual.
6. Substrate design including waterproofing and the structural design of the timber substrate and its connections are not included in this specification and must be carried out by others.
7. The 3x coachscrews illustrated may be replaced with 2x M8 threaded rod extending and bolting right through the joists. Washer to be stainless steel & EPDM with FN8 nut on top, 50mm square stainless steel washers, stainless steel washers, and nyloc nut (FN8N) on the underside.

Specifications subject to change without notice

'METROPOLIS' - WET TIMBER, 90MM JOIST, SCREWS

This is a Standard Fixing Specification for the 'Metropolis' Styles to the timber substrates using the AZM2 channel. It must only be used in conjunction with the relevant Style Specifications in Chapter 2. Installation must be completed in accordance with the Installation Guide in Chapter 5 and all other relevant portions of this manual.

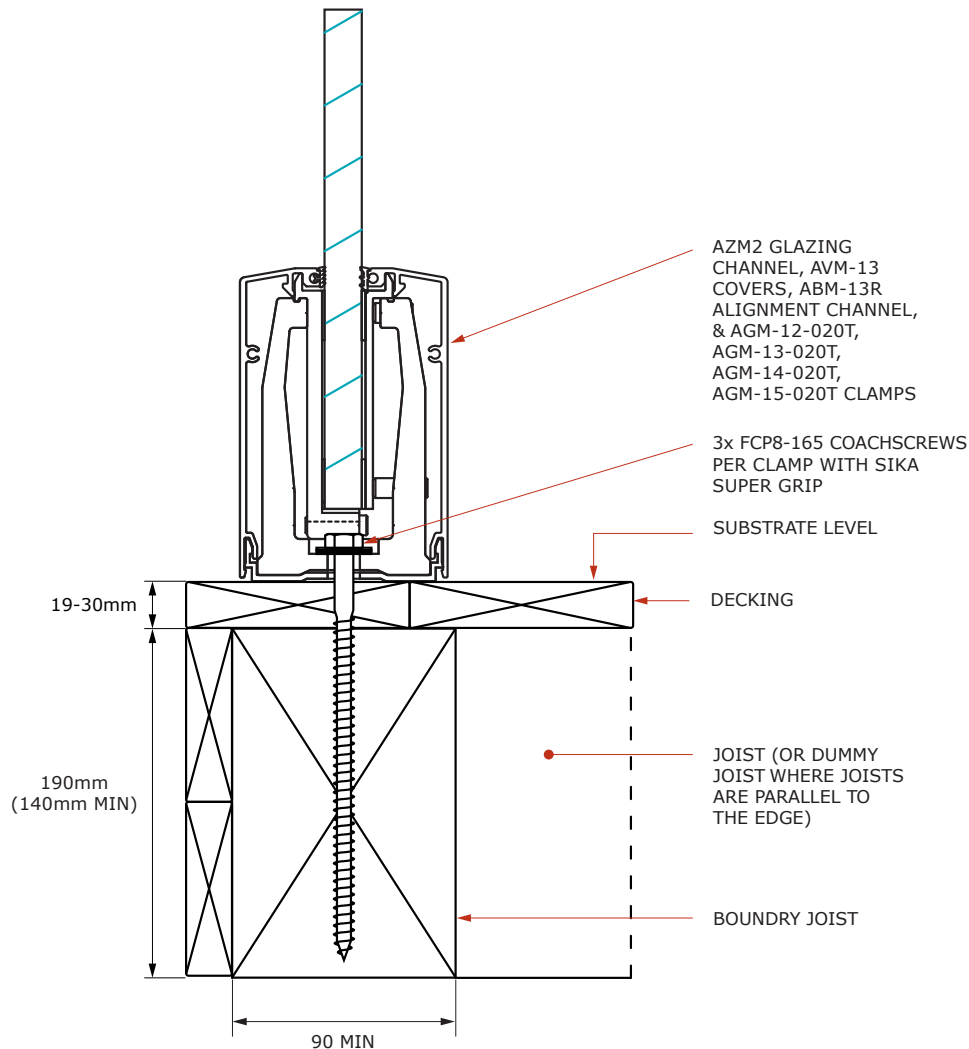

NOTES RELATING TO THIS SPECIFICATION

1. Structural timber must be Pinus Radiata VSG8 or MSG8, or higher, see General Notes on Page 78.
2. Fasteners shall be positioned on the center groove line. The 90mm wide timber joist, can be a structurally laminated timber beam, but it **cannot** consist of two x 45mm wide timber joists.
3. Washers to be fitted under coachscrews shall be stainless steel & polymer washers.
4. A level and uniform surface must be provided beneath the Glazing Channel. The Glazing Channel is not recommended to be installed over tiles.
5. Fabrication and Installation are to be in accordance with the relevant requirements of the Assembly Specifications in Chapter 4, the Installation Guides in Chapter 5, and other applicable portions of this Frameless Glass Manual.
6. Substrate design including waterproofing and the structural design of the timber substrate and its connections are not included in this specification and must be carried out by others.
7. The 3x coachscrews illustrated may be replaced with 2x M8 threaded rod extending and bolting right through the joists. Washer to be stainless steel & EPDM with FN8 nut on top, 50mm square stainless steel washers, stainless steel washers, and nyloc nut (FN8N) on the underside.

FIXING SPECIFICATIONS

NZBAL-D13.1 | SPEC ID FS.2T.05.60

'METROPOLIS' - WET TIMBER, 135MM JOIST, SCREWS

This is a Standard Fixing Specification for the 'Metropolis' Styles to the timber substrates using the AZM2 channel. It must only be used in conjunction with the relevant Style Specifications in Chapter 2. Installation must be completed in accordance with the Installation Guide in Chapter 5 and all other relevant portions of this manual.

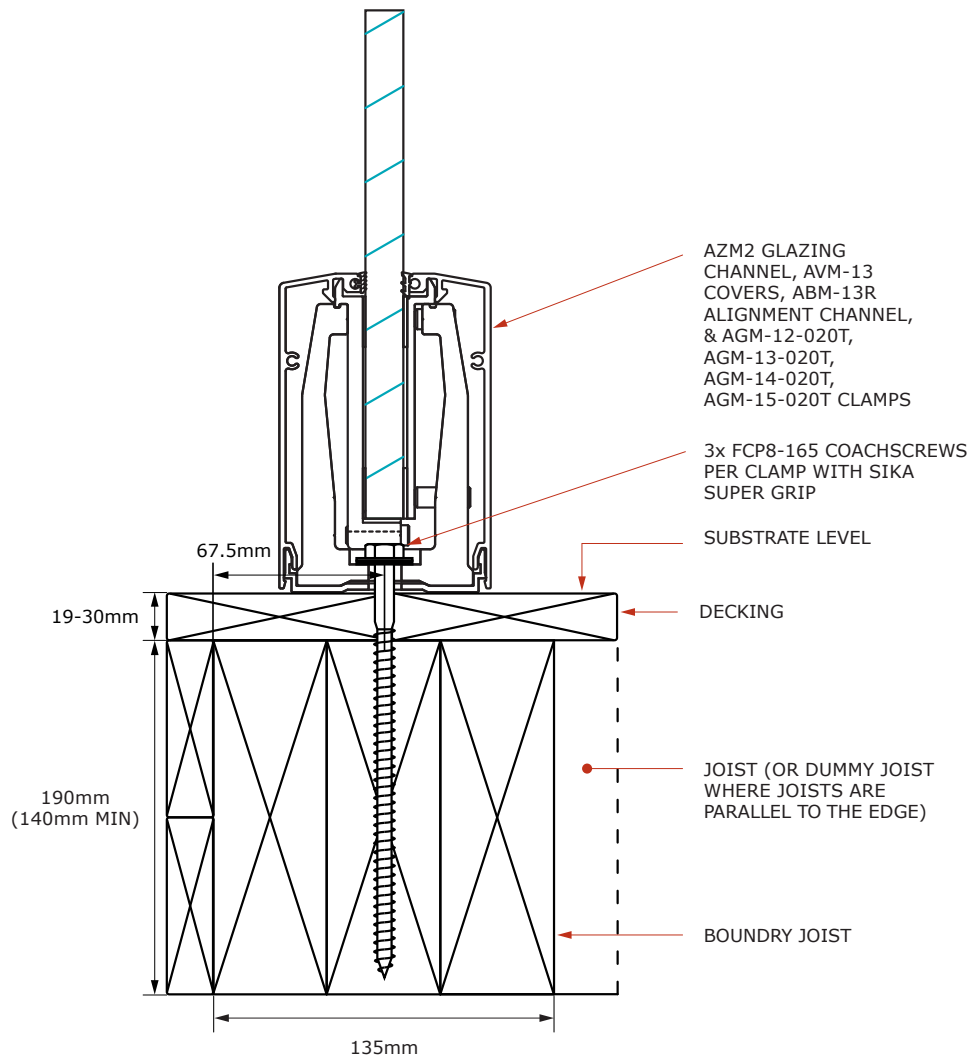

NOTES RELATING TO THIS SPECIFICATION

1. Structural timber must be Pinus Radiata VSG8 or MSG8, or higher, see General Notes on Page 78.
2. For details of fasteners refer to General Notes on Page 78 note 3. Fasteners shall be positioned on the center groove line.
3. Washers to be fitted under coachscrews shall be stainless steel & polymer washers.
4. A level and uniform surface must be provided beneath the Glazing Channel. The Glazing Channel is not recommended to be installed over tiles.
5. Fabrication and Installation are to be in accordance with the relevant requirements of the Assembly Specifications in Chapter 4, the Installation Guides in Chapter 5, and other applicable portions of this Frameless Glass Manual.
6. Substrate design including waterproofing and the structural design of the timber substrate and its connections are not included in this specification and must be carried out by others.
7. The 3x coachscrews illustrated may be replaced with 2x M8 threaded rod extending and bolting right through the joists. Washer to be stainless steel & EPDM with FN8 nut on top, 50mm square stainless steel washers, stainless steel washers, and nyloc nut (FN8N) on the underside.

Specifications subject to change without notice

'METROPOLIS' - CONCRETE

This is a Standard Fixing Specification for the 'Metropolis' Styles to the concrete substrates using the AZM2 channel. It must only be used in conjunction with the relevant Style Specifications in Chapter 2. Installation must be completed in accordance with the Installation Guide in Chapter 5 and all other relevant portions of this manual.

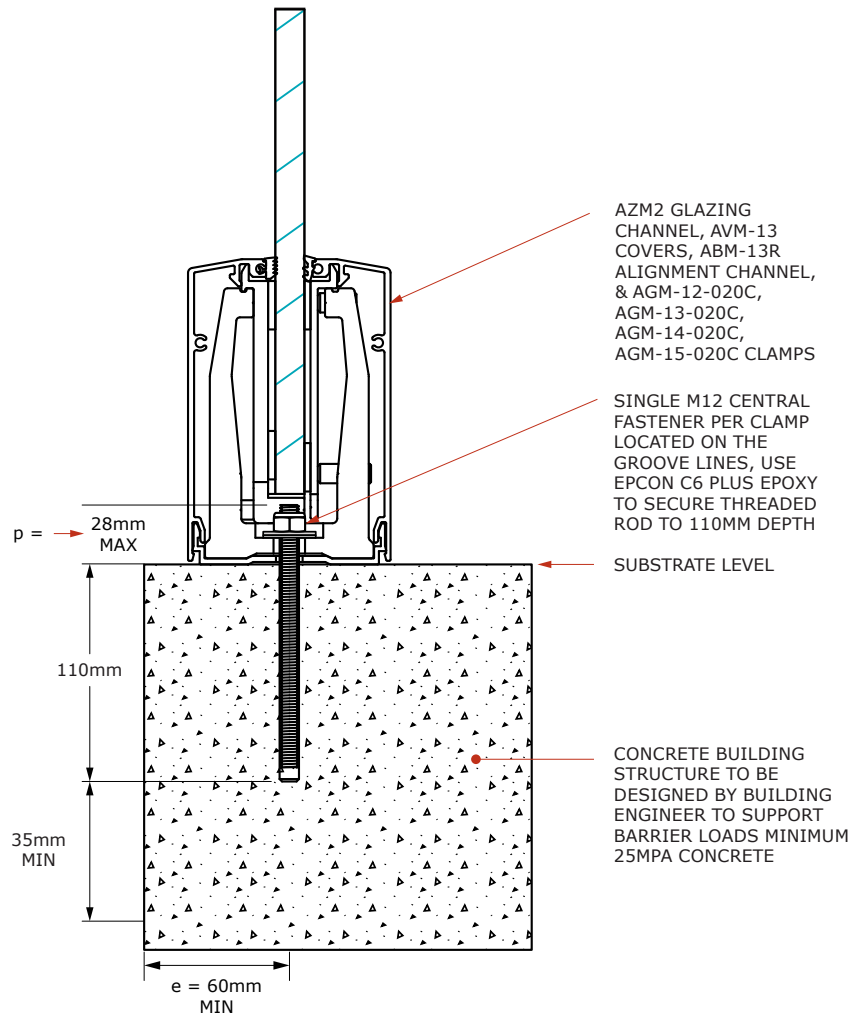

NOTES RELATING TO THIS SPECIFICATION

1. For details of approved fasteners refer to General Notes on Page 80 note 3 and note 6.
2. Washers to be fitted under M12 studs shall be either a stainless steel 'neoprene bonded type' washer or a stainless steel washer & EPDM washer, NOT polymer washers.
3. The surface must be level and uniform beneath the Glazing Channel is not recommended to be installed over tiles.
4. For fixing AZM2 channel to infill concrete in masonry bond beams, increase minimum edge distance (e) to 70mm and increase stud embedment depth (d) by 15mm per fixing.
5. Fabrication and Installation are to be in accordance with the relevant requirements of the NZ Building Code, the Assembly Specifications in Chapter 4, the Installation Guides in Chapter 5, and other applicable portions of this Frameless Manual.
6. Substrate design, including waterproofing, structural adequacy of the slab and reinforcing, is beyond the scope of this specification. A minimum 28 day Compressive Strength of 25MPa (as required for substrate design).

FIXING SPECIFICATIONS

NZBAL-D13.1 | SPEC ID FS.5T.22.60

'METROPOLIS' - STEEL

This is a Standard Fixing Specification for the 'Metropolis' Style to the steel substrates using the AZM2 channel. It must only be used in conjunction with the relevant Style Specifications in Chapter 2. Installation must be completed in accordance with the Installation Guide in Chapter 5 and all other relevant portions of this manual.

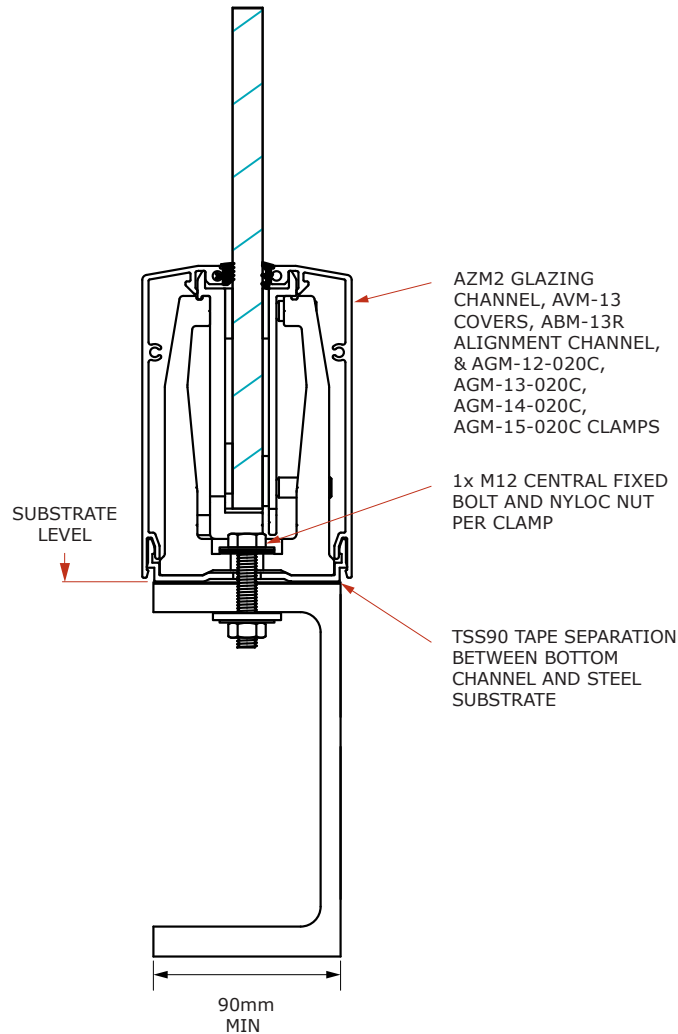

NOTES RELATING TO THIS SPECIFICATION

1. For details of approved fasteners, refer to General Notes for Steel Substrates on Page 82.
2. M12 bolts shall be Class 70 stainless steel and supplied by UNEX (M12 Bolts are UNEX code FB12-XX where XX is replaced by the length in mm of the bolt e.g. FB12-50 is a 50mm M12 bolt, typically used).
3. Washers to be fitted under M12 studs shall be either a stainless steel 'neoprene bonded type' washer or a stainless steel washer & EPDM washer, NOT polymer washers.
4. Holes drilled in steel shall be given an appropriate coating to avoid corrosion.
5. Substrate design, including waterproofing, is beyond the scope of this specification and shall be carried out by others.

'PANORAMA' - DRY TIMBER, 90mm EDGE JOIST

This is a Standard Fixing Specification for the 'Panorama' AZS3® Balustrade system. It must only be used in conjunction with the relevant Style Specification in Chapter 2. Installation must be completed in accordance with the Installation Guide in Chapter 5 and all other relevant portions of this manual.

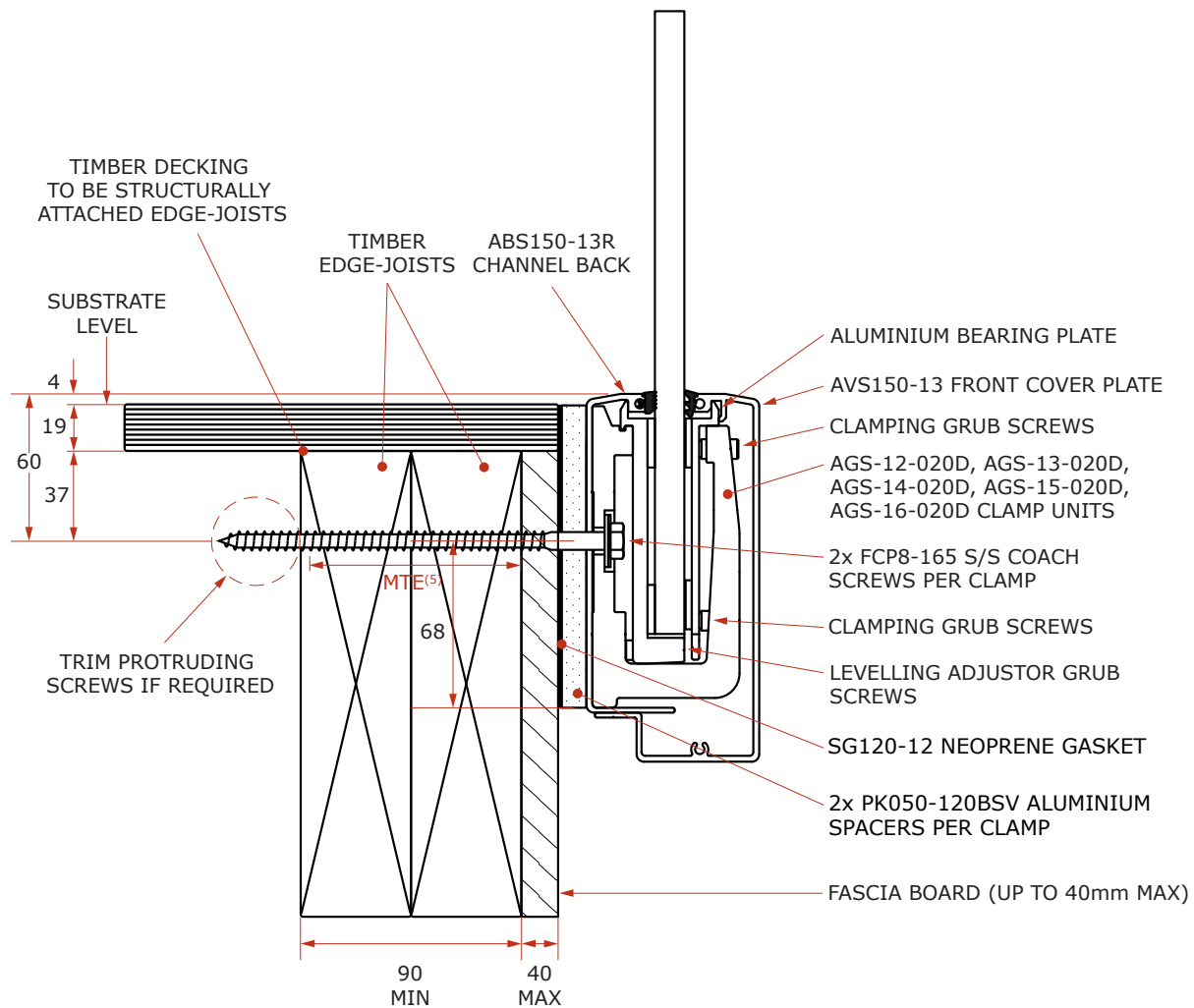

NOTES RELATING TO THIS SPECIFICATION

1. Structural timber must be Pinus Radiata VSG8 or MSG8, or higher, see General Notes on Page 78.
2. Cavities between the ABS150-13R back alignment channel and the supporting substrate must be packed solid with No 1 Pinus Radiata or material having an equivalent bearing strength and durability.
3. All FCP8-165 coach screws used in this specification, must be supplied by UNEX (includes washers).
4. Substrate design including waterproofing and structural design of the timber substrate and its connections are not included in this specification and must be carried out by others.
5. MTE denotes 'Minimum Thread Engagement'. This specification is based on an MTE of 86mm.
6. The 2x coachscrews illustrated may be replaced with 2x M8 threaded rod extending and bolting right through the joists. Washer to be stainless steel & EPDM or neo-bonded washers (UNEX code FW8-20N) with FN8 nut within the clamp and 50mm square stainless steel washers, stainless steel washers, and nyloc nut (FN8N) on the inside.

FIXING SPECIFICATIONS

NZBAL-D13.1 | SPEC ID **FS.2S.05.61**

'PANORAMA' - WET TIMBER, 135mm EDGE JOIST

This is a Standard Fixing Specification for the 'Panorama' AZS3® Balustrade system. It must only be used in conjunction with the relevant Style Specification in Chapter 2. Installation must be completed in accordance with the Installation Guide in Chapter 5 and all other relevant portions of this manual.

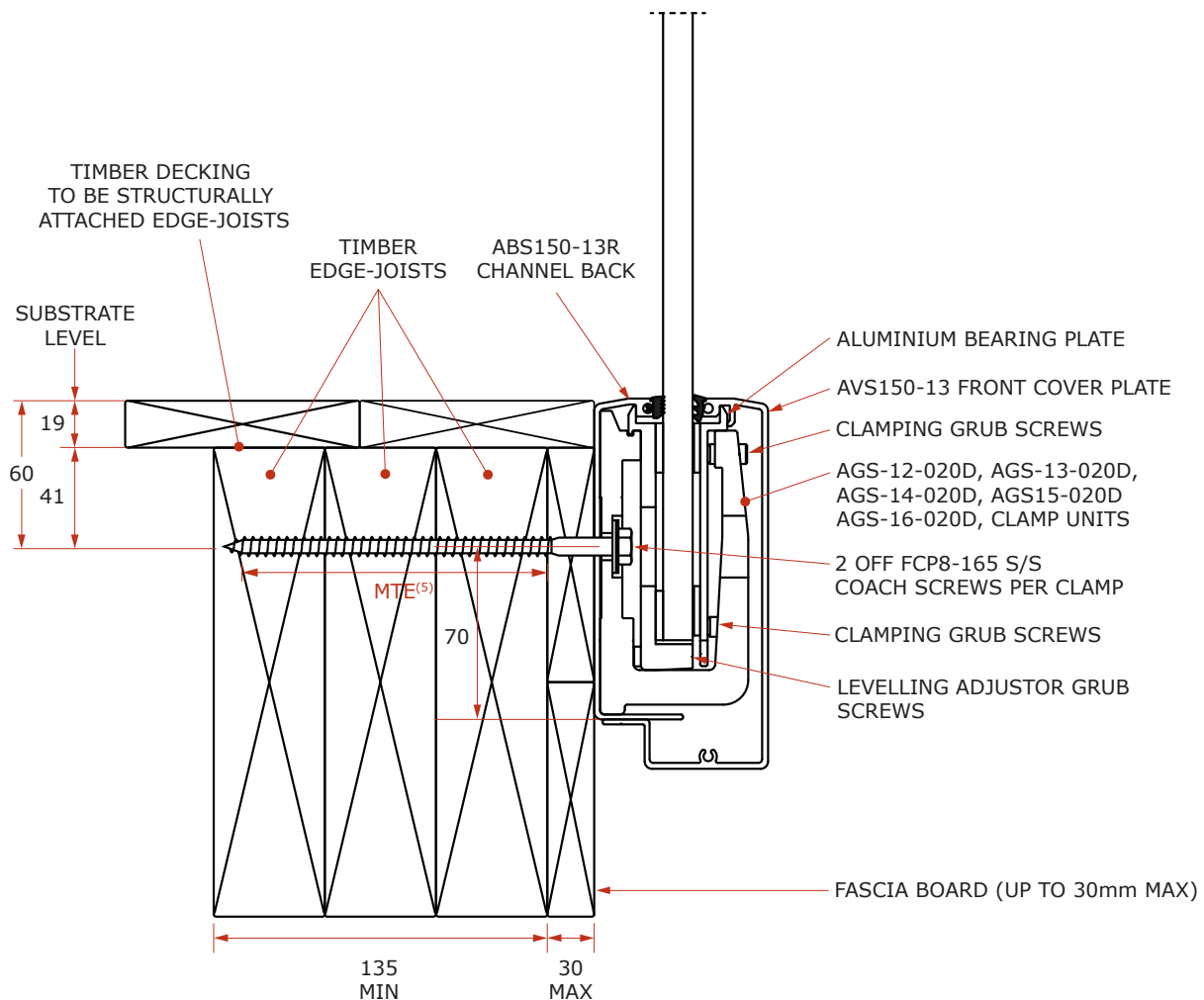

NOTES RELATING TO THIS SPECIFICATION

1. Structural timber must be Pinus Radiata VSG8 or MSG8, or higher, see General Notes on Page 78.
2. Cavities between the ABS150-13R back alignment channel and the supporting substrate must be packed solid with No 1 Pinus Radiata or material having an equivalent bearing strength and durability.
3. All FCP8-165 coach screws used in this specification, must be supplied by UNEX (includes washers).
4. Substrate design including waterproofing and structural design of the timber substrate and its connections are not included in this specification and must be carried out by others.
5. MTE denotes 'Minimum Thread Engagement'. This specification is based on an MTE of 115mm when used with **Sika Supergrip 2 hour**.
6. The 2x coachscrews illustrated may be replaced with 2x M8 threaded rod extending and bolting right through the joists. Washer to be stainless steel & EPDM or neo-bonded washers (UNEX code FW8-20N) with FN8 nut within the clamp and 50mm square stainless steel washers, stainless steel washers, and nyloc nut (FN8N) on the inside.

Specifications subject to change without notice

'PANORAMA' - CONCRETE, CENTRAL EPOXY ANCHORS

This is a Standard Fixing Specification for the 'Panorama' AZS3® Balustrade system. It must only be used in conjunction with the relevant Style Specification in Chapter 2. Installation must be completed in accordance with the Installation Guide in Chapter 5 and all other relevant portions of this manual.

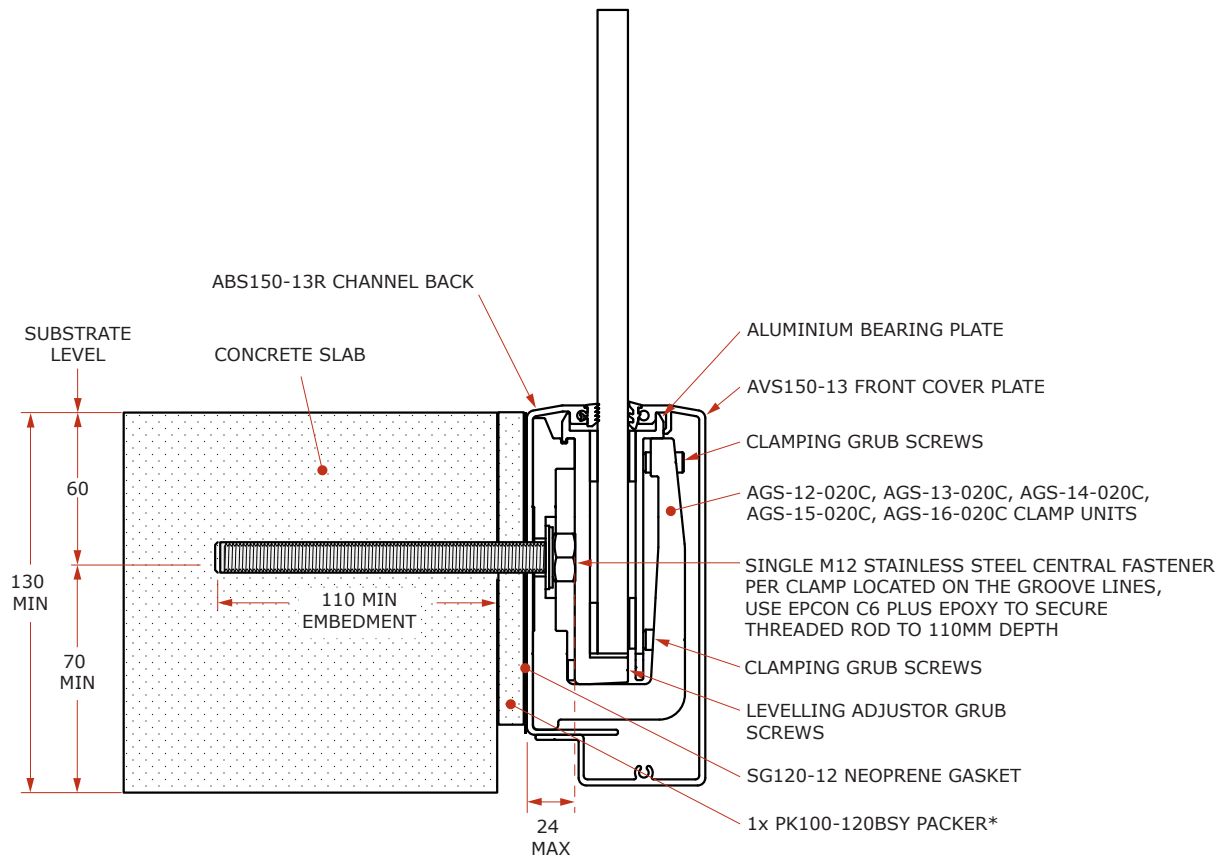

NOTES RELATING TO THIS SPECIFICATION

1. Concrete shall have a 28 day Compressive Strength of 20 MPa, or higher, see General Notes on Page 80.
2. M12 threaded rods/studs are manufactured from 316 S/S with a minimum ultimate tensile stress of 700 MPa and supplied by UNEX (M12 threaded rods are UNEX code FE12-XXX where XXX is replaced by the length in mm of the rod, e.g. FE12-150 is a 150mm M12 rod, typically used). Where a plaster finish, fascia, or other such element is positioned between the channel and the substrate, the length of the threaded rod needs to be increased by the same amount to maintain the specified embedment in the structural concrete. Studs shall protrude 24mm MAX to ensure a 1mm minimum gap to glass, excluding any allowance for packers or leveling.
3. For washer fitted under all S/S stud nuts (Part No. FN12) use EPDM between the stainless steel washer and the clamp unit.
4. FE12-XXX studs as described above shall be installed and anchored into concrete using the Epoxy Epcon C6 Plus system (UNEX Code TEC2) in accordance with the manufacturer's instructions.
5. Substrate design, including waterproofing, is beyond the scope of this specification and shall be carried out by others.
6. *Packer required for water egress on external applications, not required for internal applications.

FIXING SPECIFICATIONS

NZBAL-D13.1 | FS.5S.06.61

'PANORAMA' - STEEL PFC, CENTRAL BOLTS

This is a Standard Fixing Specification for the 'Panorama' AZS3® Balustrade system. It must only be used in conjunction with the relevant Style Specification in Chapter 2. Installation must be completed in accordance with the Installation Guide in Chapter 5 and all other relevant portions of this manual.

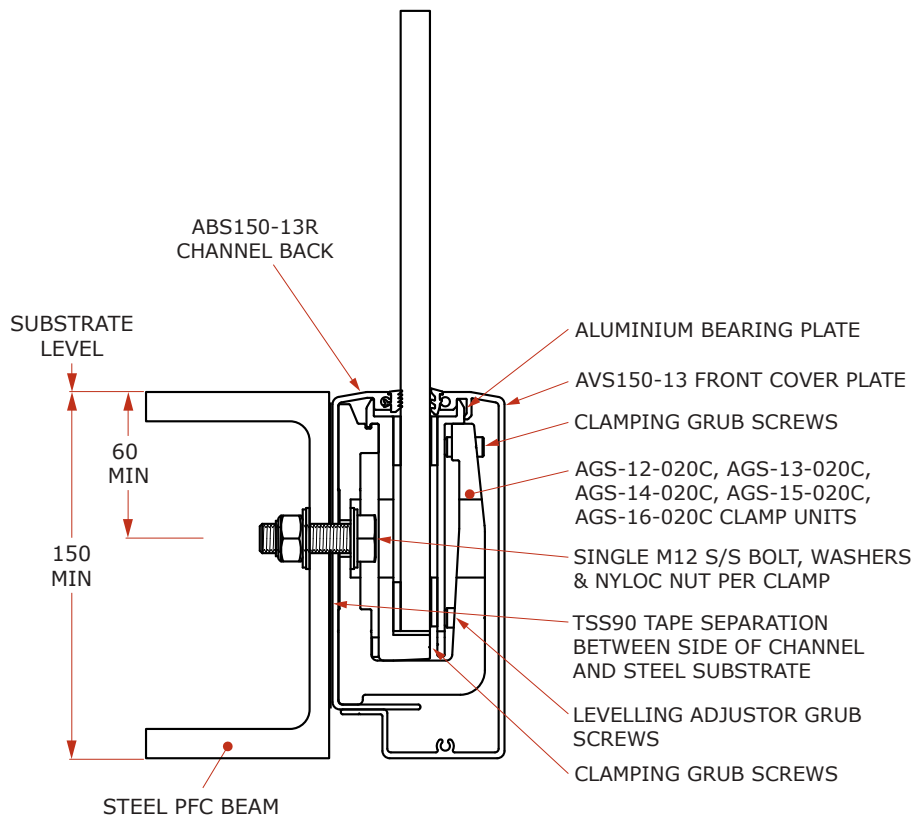

NOTES RELATING TO THIS SPECIFICATION

1. For details of approved fasteners, refer to General Notes for Steel Substrates on Page 82.
2. M12 bolts shall be Class 70 stainless steel and supplied by UNEX (M12 Bolts are UNEX code FB12-XX where XX is replaced by the length in mm of the bolt e.g. FB12-40 is a 40mm M12 bolt, typically used). Where any element is positioned between the channel and the substrate, the length of the bolt needs to be increased by the same amount to maintain enough protrusion to attach the nyloc nut.
3. Washers to be fitted under M12 bolts shall be either a stainless steel 'neoprene bonded type' washer or a stainless steel washer & EPDM washer.
4. Holes drilled in steel shall be given an appropriate coating to avoid corrosion.
5. Substrate design, including waterproofing, is beyond the scope of this specification and shall be carried out by others.
6. Minimum edge distance to steel 40mm.

'ARENA-POINTS' ADJUSTABLE - STANDARD TIMBER FIXING

This is a Standard Fixing Specification for the use of Arena-Points style, and must only be used in conjunction with the Style Specification in Chapter 2. Installation must be completed in accordance with the Installation Instructions in Chapter 5. Contact UNEX for alternative Style Specifications and non-standard Fixing Methods.

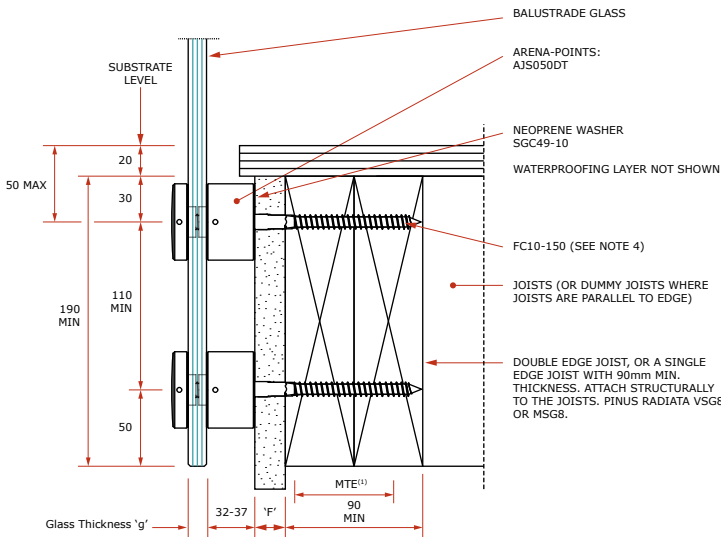

*ALL MEASUREMENTS ARE IN MILLIMETRES (MM)

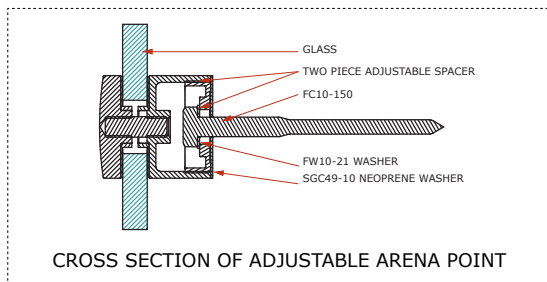

1. MTE denotes 'Minimum Thread Engagement'. This specification is based on an MTE of 75mm including the 6mm point.
2. The dimension "F" must include the thickness of the fascia plus any cavities between the fascia and the supporting substrate. This cavity must be packed solid with No 1 Pinus Radiata or material having an equivalent bearing strength and durability for a depth of 190mm and a width of 90mm centered on the points.
3. Structural design of the timber substrate and its connections including the waterproofing design, are not included in this specification and must be carried out by others.
4. F = 38mm - 53mm. The combination of fastener length and the 'F' distance, may vary to that shown in this specification, as long as the 'MTE' dimension (refer to note 1) is a minimum of 75mm.
5. The circular holes in the glass for the Arena-Points shall be 26mm Ø.
6. The Arena-Point spacer (between the glass and the substrate) is made up of two stainless steel parts, that are engaged together with an internal thread. These two parts shall not be disengaged by more than 5mm of thread.
7. For exterior installations where the timber joists could have a moisture content greater than 18%, coat the lag screws liberally with "Sika Supergrip 2 hour" adhesive before inserting them into the pilot hole.

MINIMUM GLASS THICKNESS (MILLIMETRES) & POINT SET CENTRES

HEIGHT ⁽²⁾	Description ⁽⁴⁾	Line No.	LOADING CLASS ⁽¹⁾																	
			N07C/N07R							N03R	Not Preventing Falls									
			Design Wind Speed ⁽³⁾								Design Wind Speed ⁽³⁾									
			VH		EH						M	H		VH				EH		
50	52	54	56	58	60	62	64	N/A	38	40	42	44	46	48	50	52	54	56		
1.0	Minimum Glass Thickness	1	12	12	12	15	15	15	-	-	12	10	10	10	10	10	12	12	12	15
	Maximum Horizontal distance between Points Set Centres	2	400	400	380	350	330	310	-	-	400	400	400	400	400	400	400	400	380	350
1.1	Minimum Glass Thickness	3	15	15	15	15	-	-	-	-	15	15	15	15	15	15	15	15	15	15
	Maximum Horizontal distance between Points Set Centres	4	370	340	320	300	-	-	-	-	400	400	400	400	400	400	370	340	320	300
1.2	Minimum Glass Thickness	5	15	-	-	-	-	-	-	-	15	15	15	15	15	15	15	-	-	-
	Maximum Horizontal distance between Points Set Centres	6	310	-	-	-	-	-	-	-	400	400	400	400	370	340	310	-	-	-

1. LOADING CLASS: Refer to Page 175 for the scope of the Loading Class designations.
2. HEIGHT 'H': is the overall height of the balustrade above the substrate level shown. Interpolate for Heights between those shown.
3. DESIGN WIND SPEED: in m/s, Refer to Pages 34-38 for details of applicable wind codes and the methods for determining the Design Wind Speed.
4. ARENA-POINT SET CENTRES: Figures given are the maximum spacing in mm.

FIXING SPECIFICATIONS

NZBAL-D14.0 | SPEC ID FS.35.19.65

'ARENA-POINTS' ADJUSTABLE - STANDARD CONCRETE FIXING

This is a Standard Fixing Specification for the use of Arena-Points style, and must only be used in conjunction with the Style Specification in Chapter 2. Installation must be completed in accordance with the Installation Instructions in Chapter 5. Contact UNEX for alternative Style Specifications and non-standard Fixing Methods

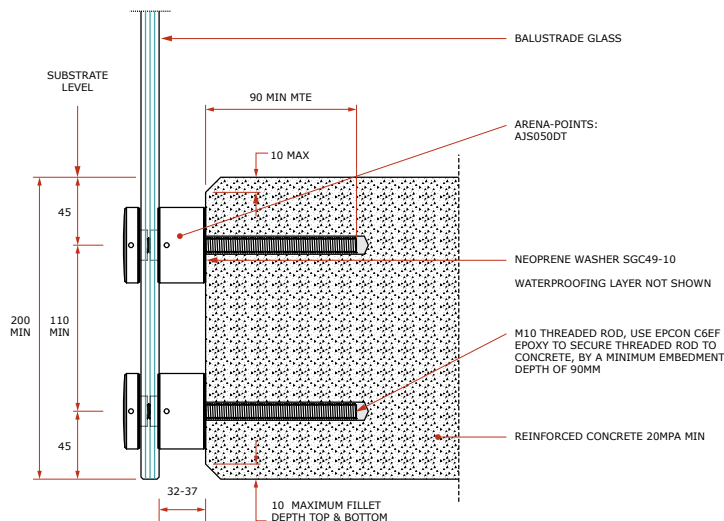

*ALL MEASUREMENTS ARE IN MILLIMETRES (MM)

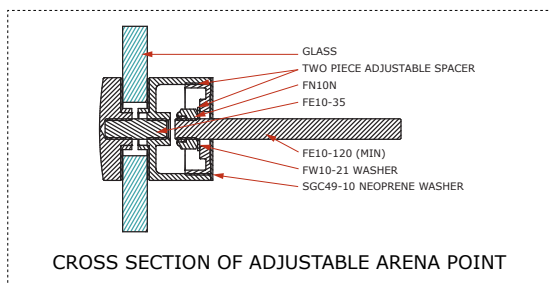

CROSS SECTION OF ADJUSTABLE ARENA POINT

1. Fixing shall be M10 threaded rods manufactured from 316 S/S as supplied by UNEX.
2. The studs as described above shall be installed and anchored into concrete using the Epoxy C6 Plus system (UNEX Code TEC2) in accordance with the manufacturer's instructions.
3. Substrate design including waterproofing and structural design of the concrete substrate and its connections are not included in this specification and must be carried out by others.
4. The circular holes in the glass for the Arena-Points shall be 26mm Ø.
5. The Arena-Point spacer (between the glass and the substrate) is made up of two stainless steel parts, that are engaged together with an internal thread. These two parts shall not be disengaged by more than 5mm of thread.

MINIMUM GLASS THICKNESS (MILLIMETRES) & POINT SET CENTRES

HEIGHT ⁽²⁾	Description ⁽⁴⁾	Line No.	LOADING CLASS ⁽¹⁾																	
			N07C/N07R							N03R	Not Preventing Falls									
			Design Wind Speed ⁽³⁾								Design Wind Speed ⁽³⁾									
			VH		EH		VH		EH		M		H		VH		EH			
50	52	54	56	58	60	62	64	N/A	38	40	42	44	46	48	50	52	54	56		
1.0	Minimum Glass Thickness	1	12	12	12	15	15	15	15	15	12	10	10	10	10	10	12	12	12	15
	Maximum Horizontal distance between Points Set Centres	2	400	400	400	400	400	400	400	400	400	400	400	400	400	400	400	400	400	400
1.1	Minimum Glass Thickness	3	15	15	15	15	15	-	-	15	15	15	15	15	15	15	15	15	15	
	Maximum Horizontal distance between Points Set Centres	4	400	400	400	400	400	380	-	-	400	400	400	400	400	400	400	400	400	400
1.2	Minimum Glass Thickness	5	15	15	15	-	-	-	-	15	15	15	15	15	15	15	15	15	15	
	Maximum Horizontal distance between Points Set Centres	6	400	400	400	-	-	-	-	400	400	400	400	400	400	400	400	400	400	-

1. LOADING CLASS: Refer to Page 175 for the scope of the Loading Class designations.
2. HEIGHT 'H': is the overall height of the balustrade above the substrate level shown. Interpolate for Heights between those shown.
3. DESIGN WIND SPEED: in m/s, Refer to Pages 34-38 for details of applicable wind codes and the methods for determining the Design Wind Speed.
4. ARENA-POINT SET CENTRES: Figures given are the maximum spacing in mm.

Specifications subject to change without notice

'ARENA-POINTS' ADJUSTABLE - STANDARD STEEL PFC FIXING

This is a Standard Fixing Specification for the use of Arena-Points style, and must only be used in conjunction with the Style Specification in Chapter 2. Installation must be completed in accordance with the Installation Instructions in Chapter 5. Contact UNEX for alternative Style Specifications and non-standard Fixing Methods

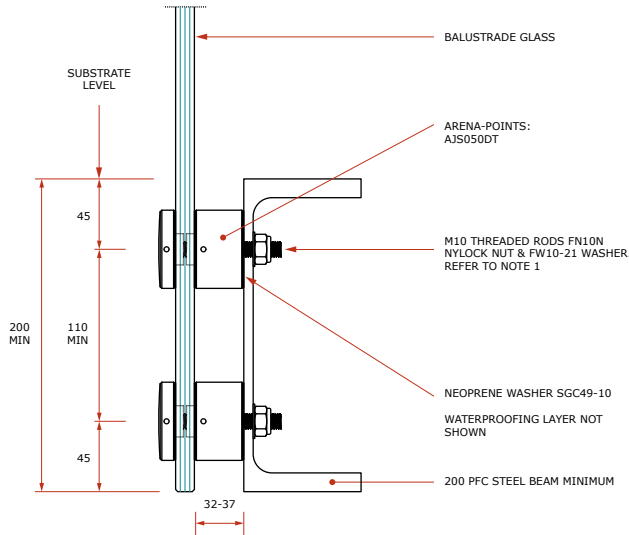

*ALL MEASUREMENTS ARE IN MILLIMETRES (MM)

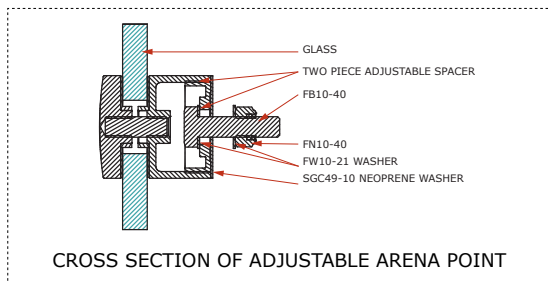

1. Fixing shall be M10 threaded rods manufactured from 316 S/S as supplied by UNEX.
2. The Arena-Point must be bearing directly and firmly on the supporting substrate. Any element in between must have an equivalent bearing strength and durability as the Arena-Point spacer.
3. Substrate design including waterproofing and structural design of the steel substrate and its connections are not included in this specification and must be carried out by others.
4. The circular holes in the glass for the Arena-Points shall be 26mm Ø.
5. The Arena-Point spacer (between the glass and the substrate) is made up of two stainless steel parts, that are engaged together with an internal thread. These two parts shall not be disengaged by more than 5mm of thread.

MINIMUM GLASS THICKNESS (MILLIMETRES) & POINT SET CENTRES

HEIGHT ⁽²⁾	Description ⁽⁴⁾	Line No.	LOADING CLASS ⁽¹⁾																		
			N07C/N07R									N03R	Not Preventing Falls								
			Design Wind Speed ⁽³⁾										Design Wind Speed ⁽³⁾								
			VH			EH							M		H		VH		EH		
50	52	54	56	58	60	62	64	64	N/A	38	40	42	44	46	48	50	52	54	56		
1.0	Minimum Glass Thickness	1	12	12	12	15	15	15	15	15	12	10	10	10	10	10	12	12	12	12	15
	Maximum Horizontal distance between Points Set Centres	2	400	400	400	400	400	400	400	400	400	400	400	400	400	400	400	400	400	400	400
1.1	Minimum Glass Thickness	3	15	15	15	15	15	15	-	-	15	15	15	15	15	15	15	15	15	15	15
	Maximum Horizontal distance between Points Set Centres	4	400	400	400	400	400	380	-	-	400	400	400	400	400	400	400	400	400	400	400
1.2	Minimum Glass Thickness	5	15	15	15	-	-	-	-	-	15	15	15	15	15	15	15	15	15	15	-
	Maximum Horizontal distance between Points Set Centres	6	400	400	380	-	-	-	-	-	400	400	400	400	400	400	400	400	400	400	-

1. LOADING CLASS: Refer to Page 175 for the scope of the Loading Class designations.
2. HEIGHT 'H': is the overall height of the balustrade above the substrate level shown. Interpolate for Heights between those shown.
3. DESIGN WIND SPEED: in m/s, Refer to Pages 34-38 for details of applicable wind codes and the methods for determining the Design Wind Speed.
4. ARENA-POINT CENTRES: Figures given are the maximum spacing in mm.

FIXING SPECIFICATIONS

NZBAL-D14.0 | SPEC ID **FS.2T.02.66**

'GLASSTRUT - TOP FIXED' - WET TIMBER

This is a Standard Fixing Specification for the 'GlasStrut' Styles to the timber substrates. It must only be used in conjunction with the relevant Style Specifications in Chapter 2. Installation must be completed in accordance with the Installation Guide in Chapter 5 all other relevant portions of this manual.

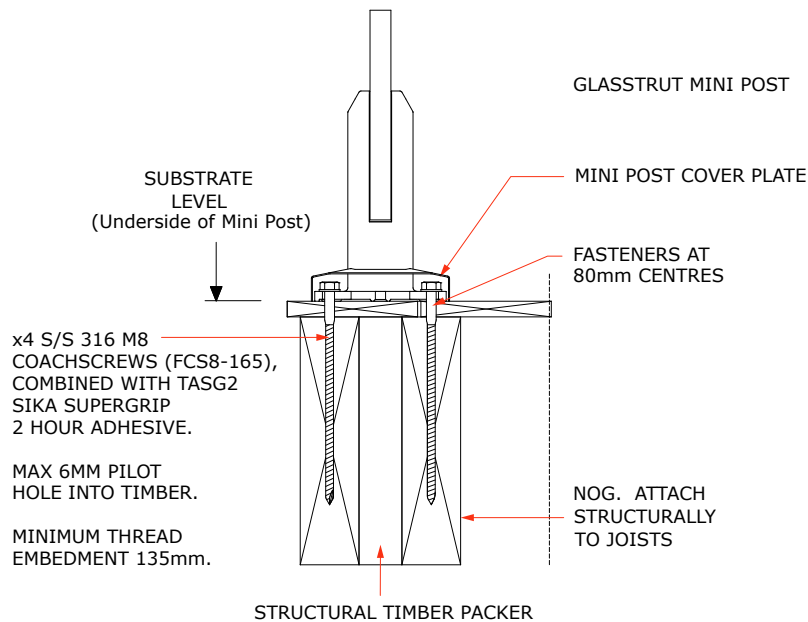

1. Structural timber must be Pinus Radiata VSG8 or MSG8, or higher, see General Notes on Page 78.
2. For details of fasteners refer to General Notes on Page 78 note 3.
3. Washers to be fitted under screw and bolt heads shall be as follows; For 8mm coachscrews - 22mm O.D. S/S washer (Part No. FW822)
4. A level and uniform surface must be provided beneath the mini post. The Mini Post is not recommended to be installed over tiles.
5. Substrate design including waterproofing and the structural design of the timber substrate and its connections are not included in this specification and must be carried out by others.
6. Important, the FC8-165 coachscrews in this specification are to be used with the "Sika Supergrip 30 Minute" adhesive system (TASG).

MAXIMUM MINI POST CENTRES 'S max' (metres)

HEIGHT ⁽²⁾	Description ⁽⁴⁾	No of Mini Posts	LOADING CLASS ⁽¹⁾																		
			N07C/N07R									N03R	Not Preventing Falls								
			Design Wind Speed ⁽³⁾										Design Wind Speed ⁽³⁾								
			VH			EH							M		H		VH		EH		
50	52	54	56	58	60	62	64	64	N/A	38	40	42	44	46	48	50	52	54	56		
1.0	Max Horizontal distance between Mini Post Centres 12mm Toughened Glass	2	0.64	0.64	0.64	0.64	0.56	0.48	0.41	0.35	1.0	1.0	1.0	1.0	1.0	1.0	1.0	1.0	1.0	1.0	1.0
		3	0.63	0.63	0.63	0.63	0.57	0.51	0.46	0.41	1.0	1.0	1.0	1.0	1.0	1.0	1.0	1.0	1.0	1.0	1.0
1.1	Max Horizontal distance between Mini Post Centres 12mm Toughened Glass	2	0.53	0.53	0.50	0.42	0.36	-	-	-	1.0	1.0	1.0	1.0	1.0	1.0	1.0	0.98	0.87	0.76	
		3	0.55	0.55	0.53	0.47	0.42	0.37	0.33	-	1.0	1.0	1.0	1.0	1.0	1.0	1.0	0.98	0.87	0.76	
1.2	Max Horizontal distance between Mini Post Centres 12mm Toughened Glass	2	0.44	0.40	0.33	-	-	-	-	-	1.0	1.0	1.0	1.0	1.0	0.96	0.84	0.73	0.63	0.55	
		3	0.48	0.45	0.39	0.35	0.30	-	-	-	1.0	1.0	1.0	1.0	1.0	0.96	0.84	0.73	0.63	0.55	

1. LOADING CLASS: Refer to Page 175 for the scope of the Loading Class designations.
2. HEIGHT 'H': is the overall height of the balustrade above the substrate level shown. Interpolate for Heights between those shown.
3. DESIGN WIND SPEED: in m/s, Refer to Pages 34-38 for details of applicable wind codes and the methods for determining the Design Wind Speed.
4. GLASSTRUT MINI POST CENTRES: The figures in the table represent maximum spacing (in metres).

Specifications subject to change without notice

‘GLASSTRUT - TOP FIXED’ - CONCRETE

This is a Standard Fixing Specification for the ‘GlasStrut’ Styles to the concrete substrates. It must only be used in conjunction with the relevant Style Specifications in Chapter 2. Installation must be completed in accordance with the Installation Guide in Chapter 5 and all other relevant portions of this manual.

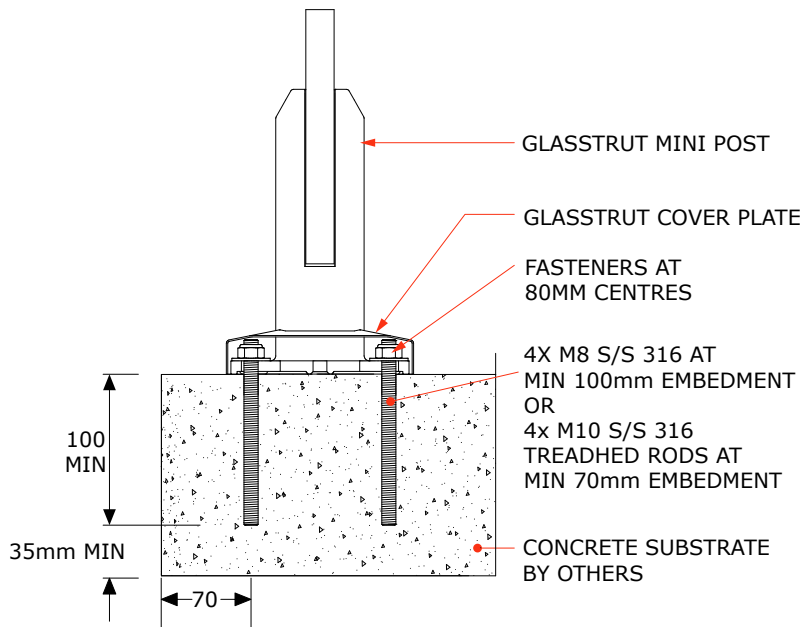

1. Fixings shall be epoxied into the concrete substrate as shown using Ramset C6 Plus Epoxy in accordance with manufacturer specifications.
2. For details of approved fasteners refer to General Notes on Page 80 note 3 and note 6.
3. Hex nut and stainless steel washer to be used for each bolt head.
4. For details of anchoring studs to the substrate refer to General Notes Page 112 note 6.
5. Substrate design, including waterproofing, structural adequacy of the slab and reinforcing, is beyond the scope of this specification. A minimum 28 day Compressive Strength of 20MPa (as required for substrate design).

MAXIMUM MINI POST CENTRES 'S max' (metres)																					
HEIGHT ⁽²⁾	Description ⁽⁴⁾	No of Mini Posts	LOADING CLASS ⁽¹⁾																		
			N07C/N07R								N03R	Not Preventing Falls									
			Design Wind Speed ⁽³⁾									Design Wind Speed ⁽³⁾									
			VH		EH		VH		EH			M		H		VH		EH			
50	52	54	56	58	60	62	64	N/A	38	40	42	44	46	48	50	52	54	56			
1.0	Max Horizontal distance between Mini Post Centres 12mm Toughened Glass	2	0.72	0.72	0.72	0.71	0.62	0.54	0.47	0.40	1.10	1.10	1.10	1.10	1.10	1.10	1.10	1.10	1.10	1.01	
		3	0.78	0.78	0.78	0.78	0.70	0.64	0.58	0.52	1.10	1.10	1.10	1.10	1.10	1.10	1.10	1.10	1.10	1.01	
1.1	Max Horizontal distance between Mini Post Centres 12mm Toughened Glass	2	0.55	0.55	0.52	0.44	0.37	0.31	-	-	1.10	1.10	1.10	1.10	1.10	1.10	1.10	1.10	1.05	0.93	0.82
		3	0.65	0.65	0.62	0.56	0.50	0.45	0.40	0.36	1.10	1.10	1.10	1.10	1.10	1.10	0.99	0.89	0.81	0.73	
1.2	Max Horizontal distance between Mini Post Centres 12mm Toughened Glass	2	0.40	0.36	-	-	-	-	-	-	1.10	1.10	1.10	1.10	1.10	0.98	0.86	0.75	0.65	0.56	
		3	0.65	0.61	0.55	0.49	0.44	0.39	0.34	0.30	1.10	1.10	1.10	1.10	1.05	0.94	0.84	0.75	0.68	0.61	

1. LOADING CLASS: Refer to Page 175 for the scope of the Loading Class designations.
 2. HEIGHT 'H': is the overall height of the balustrade above the substrate level shown. Interpolate for Heights between those shown.
 3. DESIGN WIND SPEED: in m/s, Refer to Pages 34-38 for details of applicable wind codes and the methods for determining the Design Wind Speed.
 4. GLASSTRUT MINI POST CENTRES: The figures in the table represent maximum spacing (in metres).

FIXING SPECIFICATIONS

NZBAL-D14.0 | SPEC ID **FS.5T.02.66**

'GLASSTRUT - TOP FIXED' - STEEL

This is a Standard Fixing Specification for the 'GlasStrut' Style to the steel substrates. It must only be used in conjunction with the relevant Style Specifications in Chapter 2. Installation must be completed in accordance with the Installation Guide in Chapter 5 and all other relevant portions of this manual.

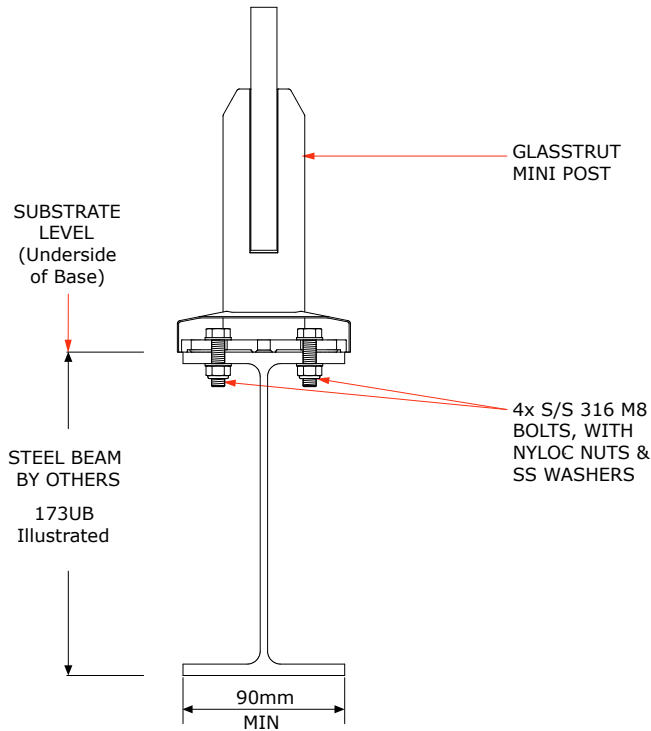

1. For details of approved fasteners, refer to General Notes for Steel Substrates on Page 82.
2. All bolts, washers and nyloc nuts fixings shall be Class 70 316 stainless steel.
3. Nyloc Hex nut and stainless steel washers to be fitted under each bolt head. Polymer washer to be used between the steel beam and nyloc nut.
4. Holes drilled in steel shall be given an appropriate coating to avoid corrosion.
5. The steel beam shall be painted with a good quality paint system consisting of a primer and top coat.
6. Substrate design, including waterproofing, is beyond the scope of this specification and shall be carried out by others.

MAXIMUM MINI POST CENTRES 'S max' (metres)

HEIGHT ⁽²⁾	Description ⁽⁴⁾	No of Mini Posts	LOADING CLASS ⁽¹⁾																		
			N07C/N07R									N/A	Not Preventing Falls								
			Design Wind Speed ⁽³⁾										Design Wind Speed ⁽³⁾								
			VH			EH							M			H					
50	52	54	56	58	60	62	64	66	38	40	42	44	46	48	50	52	54	56			
1.0	Max Horizontal distance between Mini Post Centres 12mm Toughened Glass	2	0.72	0.72	0.72	0.71	0.62	0.54	0.47	0.40	1.10	1.10	1.10	1.10	1.10	1.10	1.10	1.10	1.10	1.10	1.01
		3	0.78	0.78	0.78	0.78	0.70	0.64	0.58	0.52	1.10	1.10	1.10	1.10	1.10	1.10	1.10	1.10	1.10	1.10	1.01
1.1	Max Horizontal distance between Mini Post Centres 12mm Toughened Glass	2	0.55	0.55	0.52	0.44	0.37	0.31	-	-	1.10	1.10	1.10	1.10	1.10	1.10	1.10	1.10	1.05	0.93	0.82
		3	0.65	0.65	0.62	0.56	0.50	0.45	0.40	0.36	1.10	1.10	1.10	1.10	1.10	1.10	0.99	0.89	0.81	0.73	
1.2	Max Horizontal distance between Mini Post Centres 12mm Toughened Glass	2	0.40	0.36	-	-	-	-	-	-	1.10	1.10	1.10	1.10	1.10	0.98	0.86	0.75	0.65	0.56	
		3	0.65	0.61	0.55	0.49	0.44	0.39	0.34	0.30	1.10	1.10	1.10	1.10	1.05	0.94	0.84	0.75	0.68	0.61	

1. LOADING CLASS: Refer to Page 175 for the scope of the Loading Class designations.
2. HEIGHT 'H': is the overall height of the balustrade above the substrate level shown. Interpolate for Heights between those shown.
3. DESIGN WIND SPEED: in m/s, Refer to Pages 34-38 for details of applicable wind codes and the methods for determining the Design Wind Speed.
4. GLASSTRUT MINI POST CENTRES: The figures in the table represent maximum spacing (in metres).

'GLASSTRUT - SIDE FIXED'- WET TIMBER, 90mm EDGE JOIST

This is a Standard Fixing Specification for the 'GlasStrut' Balustrade system. It must only be used in conjunction with the relevant Style Specification in Chapter 2. Installation must be completed in accordance with the Installation Guide in Chapter 5 and all other relevant portions of this manual.

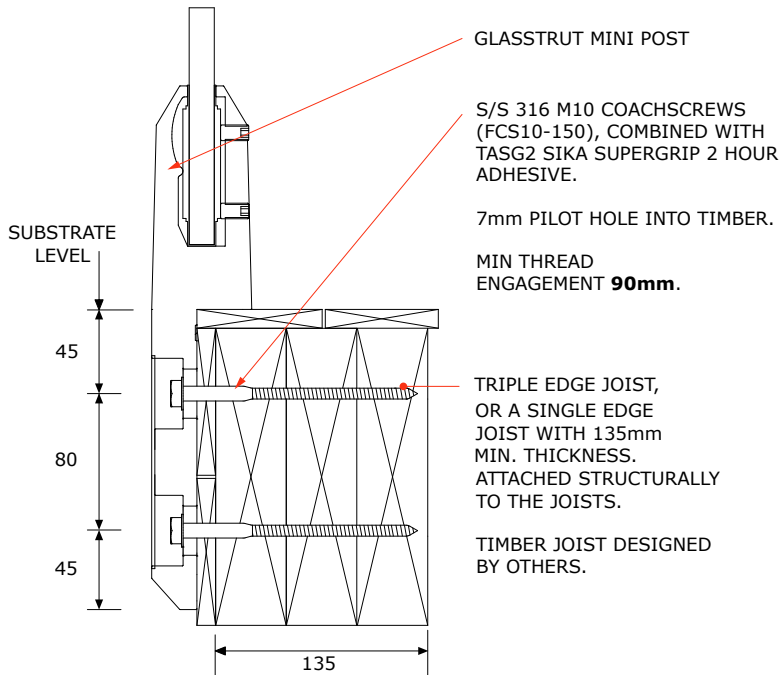

Substrate supplied by Unex Systems

1. Structural timber must be Pinus Radiata VSG8 or MSG8, or higher, see
2. Stainless steel washer (FW10-21) and Nyloc Nut (FN10N) to be used for each bolt head.
3. Substrate design including waterproofing and structural design of the timber substrate and its connections are not included in this specification and must be carried out by others.
4. Important, the coachscrews in this specification are to be used with the "Sika SuperGrip 30 Minute" adhesive system (TASG).
5. The coachscrews illustrated may be replaced with M10 bolts extending and bolting right through the joists. Washer fitted under nut to be 50mm square S/S (FW10-50SQ) S/S316 with nyloc nut (FN10N)

MAXIMUM MINI POST CENTRES 'S max' (metres)

HEIGHT ⁽²⁾	Description ⁽⁴⁾	No of Mini Posts	LOADING CLASS ⁽¹⁾																	
			N07C/N07R									N/A	Not Preventing Falls							
			Design Wind Speed ⁽³⁾										Design Wind Speed ⁽³⁾							
			VH			EH							M		H		VH		EH	
50	52	54	56	58	60	62	64	66	38	40	42	44	46	48	50	52	54	56		
1.0	Max Horizontal distance between Mini Post Centres 12mm Toughened Glass	2	0.64	0.64	0.64	0.64	0.56	0.48	0.41	0.35	0.75	0.75	0.75	0.75	0.75	0.75	0.75	0.75	0.75	0.75
		3	0.63	0.63	0.63	0.63	0.57	0.51	0.46	0.41	0.75	0.75	0.75	0.75	0.75	0.75	0.75	0.75	0.70	0.63
1.1	Max Horizontal distance between Mini Post Centres 12mm Toughened Glass	2	0.53	0.53	0.50	0.42	0.36	-	-	-	0.75	0.75	0.75	0.75	0.75	0.75	0.75	0.75	0.72	0.63
		3	0.55	0.55	0.53	0.47	0.42	0.37	0.33	-	0.75	0.75	0.75	0.75	0.75	0.75	0.66	0.59	0.53	0.47
1.2	Max Horizontal distance between Mini Post Centres 12mm Toughened Glass	2	0.44	0.40	0.33	-	-	-	-	-	0.75	0.75	0.75	0.75	0.75	0.75	0.70	0.60	0.51	0.43
		3	0.48	0.45	0.39	0.35	0.30	-	-	-	0.75	0.75	0.75	0.75	0.66	0.58	0.51	0.45	0.39	0.35

1. LOADING CLASS: Refer to Page 175 for the scope of the Loading Class designations.
2. HEIGHT 'H': is the overall height of the balustrade above the substrate level shown. Interpolate for Heights between those shown.
3. DESIGN WIND SPEED: in m/s, Refer to Pages 34-38 for details of applicable wind codes and the methods for determining the Design Wind Speed.
4. GLASSTRUT MINI POST CENTRES: The figures in the table represent maximum spacing (in metres)..

FIXING SPECIFICATIONS

NZBAL-D14.0 | SPEC ID **FS.3S.02.67**

'GLASSTRUT - SIDE FIXED' - CONCRETE, CENTRAL EPOXY ANCHORS

This is a Standard Fixing Specification for the 'GlasStrut' Balustrade system. It must only be used in conjunction with the relevant Style Specification in Chapter 2. Installation must be completed in accordance with the Installation Guide in Chapter 5 and all other relevant portions of this manual.

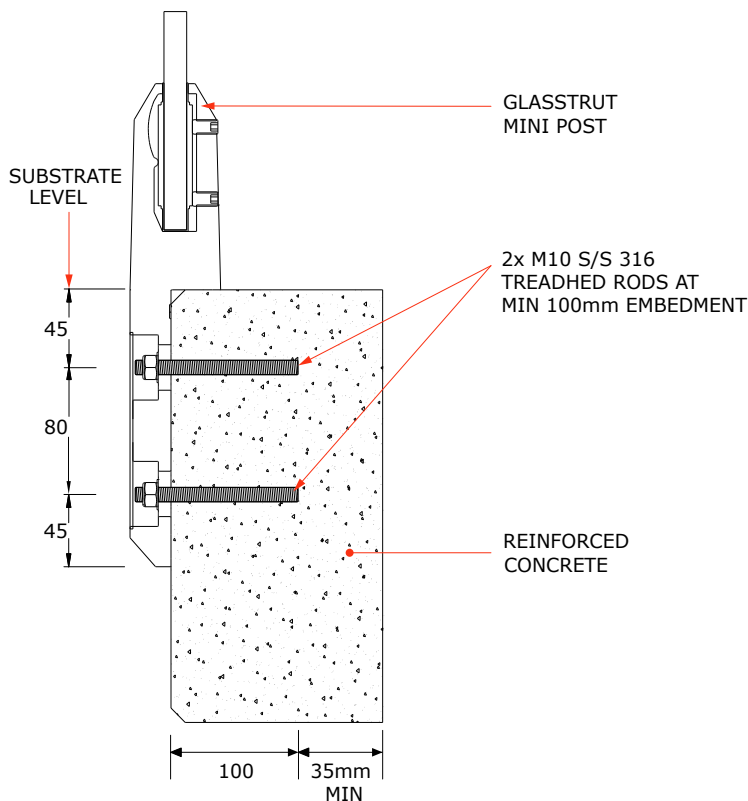

1. Fixings shall be 10 mm diameter SS 316 threaded rods, epoxied into the concrete substrate as shown using HILTI HIT-HY 200 RV3 Epoxy Chemset, or equivalent, in accordance with the manufacturer's specifications.
2. Washers to be fitted under all stud dome nuts as follows;
 - For 10mm studs - 21mm O.D. S/S washer (Part No. FW10-21) with FN10N Nyloc Nut.
3. Fabrication and installation are to be in accordance with the relevant requirements of the NZ Building Code, the Assembly Specifications in Chapter 4, the Installation Guides in Chapter 5, and other applicable portions of this Frameless Manual.
4. Substrate design, including waterproofing, is beyond the scope of this specification and shall be carried out by others. Concrete shall have a 28 day Compressive Strength of 20MPa or more (as required for substrate design) and be adequately reinforced.

MAXIMUM MINI POST CENTRES 'S max' (metres)

HEIGHT ⁽²⁾	Description ⁽⁴⁾	No of Mini Posts	LOADING CLASS ⁽¹⁾																		
			N07C/N07R									N/A	Not Preventing Falls								
			Design Wind Speed ⁽³⁾										Design Wind Speed ⁽³⁾								
			VH			EH							M			H			EH		
50	52	54	56	58	60	62	64	64	38	40	42	44	46	48	50	52	54	56			
1.0	Max Horizontal distance between Mini Post Centres 12mm Toughened Glass	2	0.72	0.72	0.72	0.71	0.62	0.54	0.47	0.40	1.10	1.10	1.10	1.10	1.10	1.10	1.10	1.10	1.10	1.10	1.01
		3	0.78	0.78	0.78	0.78	0.70	0.64	0.58	0.52	1.10	1.10	1.10	1.10	1.10	1.10	1.10	1.10	1.10	1.10	1.01
1.1	Max Horizontal distance between Mini Post Centres 12mm Toughened Glass	2	0.55	0.55	0.52	0.44	0.37	0.31	-	-	1.10	1.10	1.10	1.10	1.10	1.10	1.10	1.10	1.05	0.93	0.82
		3	0.65	0.65	0.62	0.56	0.50	0.45	0.40	0.36	1.10	1.10	1.10	1.10	1.10	1.10	0.99	0.89	0.81	0.73	
1.2	Max Horizontal distance between Mini Post Centres 12mm Toughened Glass	2	0.40	0.36	-	-	-	-	-	-	1.10	1.10	1.10	1.10	1.10	0.98	0.86	0.75	0.65	0.56	
		3	0.65	0.61	0.55	0.49	0.44	0.39	0.34	0.30	1.10	1.10	1.10	1.10	1.05	0.94	0.84	0.75	0.68	0.61	

1. LOADING CLASS: Refer to Page 175 for the scope of the Loading Class designations.
 2. HEIGHT 'H': is the overall height of the balustrade above the substrate level shown. Interpolate for Heights between those shown.
 3. DESIGN WIND SPEED: in m/s, Refer to Pages 34-38 for details of applicable wind codes and the methods for determining the Design Wind Speed.
 4. GLASSTRUT MINI POST CENTRES: The figures in the table represent maximum spacing (in metres).

'GLASSTRUT - SIDE FIXED' - STEEL PFC

This is a Standard Fixing Specification for the 'GlasStrut' Balustrade system. It must only be used in conjunction with the relevant Style Specification in Chapter 2. Installation must be completed in accordance with the Installation Guide in Chapter 5 and all other relevant portions of this manual.

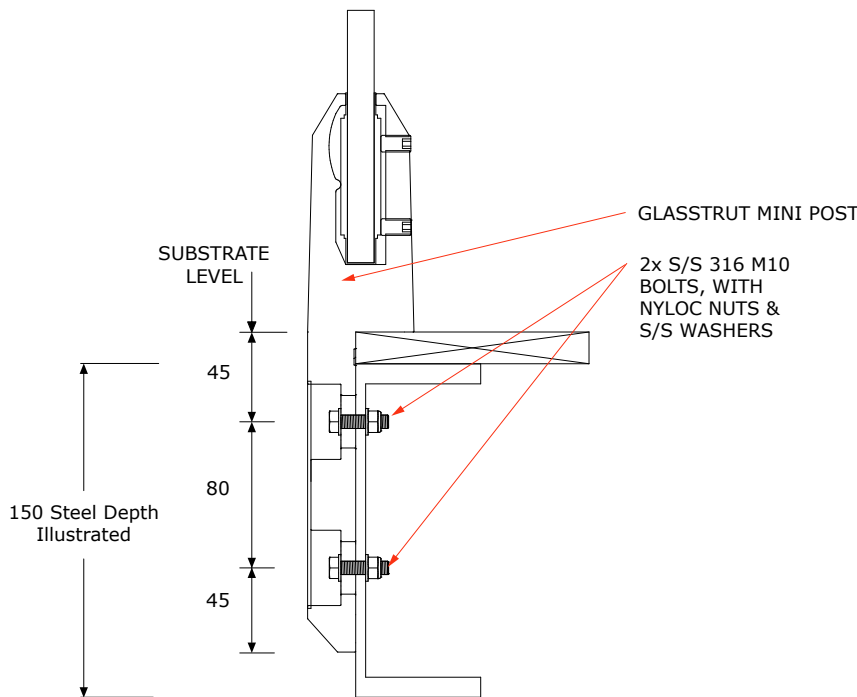

- For details of approved fasteners, refer to General Notes for Steel Substrates on Page 82.
- Washers to be fitted under all bolts as follows;
 - For 10mm bolted - 21mm O.D. S/S washer (Part No. FW10-21) with a polymer washer (Part No. FWP10-22G) between the S/S washer and the steel.
- Holes drilled in steel shall be given an appropriate coating to avoid corrosion.
- The steel beam shall be painted with a good quality paint system consisting of a primer and top coat.
- Substrate design, including waterproofing, is beyond the scope of this specification and shall be carried out by others.

MAXIMUM MINI POST CENTRES 'S max' (metres)

HEIGHT ⁽²⁾	Description ⁽⁴⁾	No of Mini Posts	LOADING CLASS ⁽¹⁾																	
			N07C/N07R									N03R	Not Preventing Falls							
			Design Wind Speed ⁽³⁾										Design Wind Speed ⁽³⁾							
			VH			EH							M			H			VH	
50	52	54	56	58	60	62	64	66	N/A	38	40	42	44	46	48	50	52	54	56	
1.0	Max Horizontal distance between Mini Post Centres 12mm Toughened Glass	2	0.72	0.72	0.72	0.71	0.62	0.54	0.47	0.40	1.10	1.10	1.10	1.10	1.10	1.10	1.10	1.10	1.10	1.10
		3	0.78	0.78	0.78	0.78	0.70	0.64	0.58	0.52	1.10	1.10	1.10	1.10	1.10	1.10	1.10	1.10	1.10	1.10
1.1	Max Horizontal distance between Mini Post Centres 12mm Toughened Glass	2	0.55	0.55	0.52	0.44	0.37	0.31	-	-	1.10	1.10	1.10	1.10	1.10	1.10	1.10	1.05	0.93	0.82
		3	0.65	0.65	0.62	0.56	0.50	0.45	0.40	0.36	1.10	1.10	1.10	1.10	1.10	1.10	0.99	0.89	0.81	0.73
1.2	Max Horizontal distance between Mini Post Centres 12mm Toughened Glass	2	0.40	0.36	-	-	-	-	-	-	1.10	1.10	1.10	1.10	1.10	0.98	0.86	0.75	0.65	0.56
		3	0.65	0.61	0.55	0.49	0.44	0.39	0.34	0.30	1.10	1.10	1.10	1.10	1.05	0.94	0.84	0.75	0.68	0.61

- LOADING CLASS: Refer to Page 175 for the scope of the Loading Class designations.
- HEIGHT 'H': is the overall height of the balustrade above the substrate level shown. Interpolate for Heights between those shown.
- DESIGN WIND SPEED: in m/s, Refer to Pages 34-38 for details of applicable wind codes and the methods for determining the Design Wind Speed.
- GLASSTRUT MINI POST CENTRES: The figures in the table represent maximum spacing (in metres).

CHAPTER 3 - FRAMELESS GLASS ASSEMBLY SPECIFICATIONS

SPEC ID	STYLE (RAIL TYPE)	
AS.60.00	`Metropolis' (NO Rail)	103
AS.60.12T	`Metropolis' (VRR Top Rail)	104
AS.60.18T	`Metropolis' (Q25 Top Rail)	105
AS.60.19T	`Metropolis' (Q40 Top Rail)	106
AS.60.14S	`Metropolis' (LRR Side Rail)	107
AS.61.00	`Panorama' (NO Rail)	108
AS.61.12T	`Panorama' (VRR Top Rail)	109
AS.61.18T	`Panorama' (Q25 Top Rail)	110
AS.61.19T	`Panorama' (Q40 Top Rail)	111
AS.	`Panorama' (Stainless Steel Side Rail)	112
AS.61.14S	`Panorama' (LRR Side Rail)	113
AS.65.00	`Arena-Points' (No Top Rail)	114
AS.65.12T	`Arena-Points' (VRR Top Rail)	115
AS.65.18T	`Arena-Points' (Q25 Top Rail)	116
AS.65.19T	`Arena-Points' (Q40 Top Rail)	117
AS.65.12S	`Arena-Points' (VRR Side Rail)	118
AS.65.14S	`Arena-Points' (LRR Side Rail)	119
AS.66.00T	`GlasStrut Top Fixed' (No Top Rail)	120
AS.66.12T	`GlasStrut Top Fixed' (VRR Top Rail)	121
AS.66.18T	`GlasStrut Top Fixed' (Q25 Top Rail)	122
AS.66.19T	`GlasStrut Top Fixed' (Q40 Top Rail)	123
AS.67.00S	`GlasStrut Side Fixed' (No Top Rail)	124
AS.67.12S	`GlasStrut Side Fixed' (VRR Top Rail)	125
AS.67.18S	`GlasStrut Side Fixed' (Q25 Top Rail)	126
AS.67.19S	`GlasStrut Side Fixed' (Q40 Top Rail)	127

Extrusions & Components

Style Specifications

Fixing Specifications

Assembly Specifications

Fabrication & Installation

'METROPOLIS' (NO RAIL)

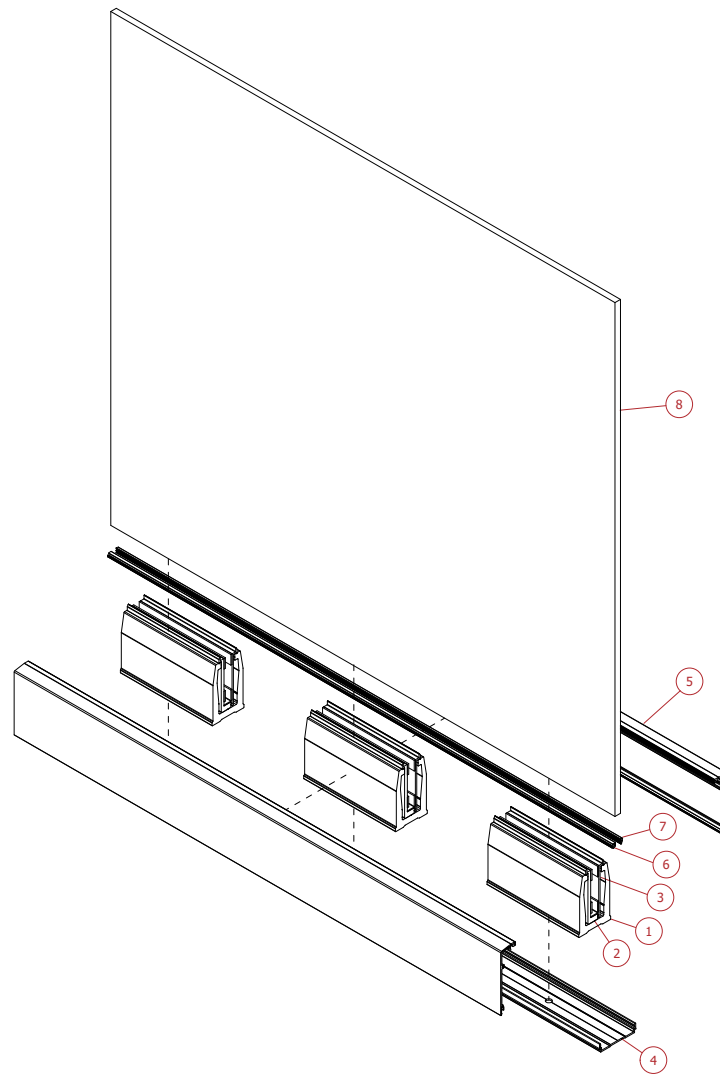

ITEM	Part Number	Description
1	AGM-00-020X	Structural block assembly for AZM2 system. Clamps glass to ABM-13R channel to vertically adjust when leveling
2	ABB	Bearing block. Part of AGM-00-020X
3	ABP	Bearing plate. Part of AGM-00-020X
4	ABM-13R	Pre-drilled alignment channel
5	AVM-13	Cover extrusion for on both sides
6	SRG40	Retained gasket, SRG40(12mm) - SRG30 (13.5mm & 14.28mm)/SRG20 (15mm)
7	SWE35	Wedge, SWE35(12mm) - SWE30 (13.5mm)/SWE25 (14.28mm & 15mm)
8	[Glass Infill]	Toughened-Laminated Safety Glass with "SentryGlas" interlayer, Refer to the Style Specification for appropriate thickness. All exposed edges to be Flat Polished.

ASSEMBLY SPECIFICATIONS

NZBAL-D13.1 | SPEC ID AS.60.12T

'METROPOLIS' (VRR TOP RAIL)

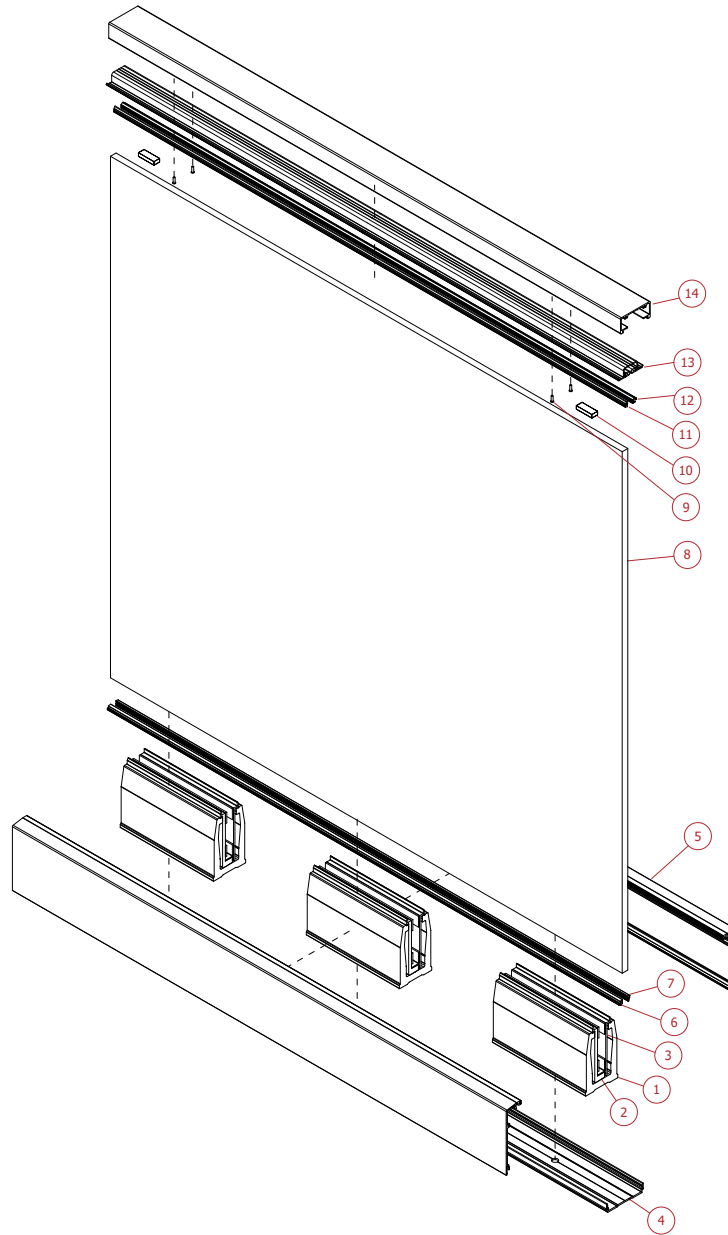

ITEM	Part Number	Description
1	AGM-00-020X	Structural block assembly for AZM2 system. Clamps glass to ABM-13R channel to vertically adjust when leveling
2	ABB	Bearing block. Part of AGM-00-020X
3	ABP	Bearing plate. Part of AGM-00-020X
4	ABM-13R	Pre-drilled alignment channel
5	AVM-13	Cover extrusion for on both sides
6	SRG40	Retained gasket, SRG40(12mm) - SRG30 (13.5mm & 14.28mm)/SRG20 (15mm)
7	SWE35	Wedge, SWE35(12mm) - SWE30 (13.5mm)/SWE25 (14.28mm & 15mm)
8	[Glass Infill]	Monolithic Toughened Safety Glass, Refer to Style Specification for appropriate thickness. Exposed edges Flat Polished.
9	FS4-4	Inner Rail rivets, 1 pair 150mm from ends and then 1000mm maximum centres between. Drill size = Ø3.3mm.
10	SBC	Setting blocks at 500mm centres to prevent over-compression of bonding silicone and protect glass during rail placement
11	SRG40	Retained gasket, SRG40(12mm) - SRG30 (13.5mm & 14.28mm)/SRG20 (15mm)
12	SWE35	Wedge, SWE35(12mm) - SWE30 (13.5mm)/SWE25 (14.28mm & 15mm)
13	PZT	Inner Top Rail, Structural silicone bond to top edge of glass
14	VRR	Top Rail

Specifications subject to change without notice

'METROPOLIS' (Q25 STAINLESS STEEL TOP RAIL)

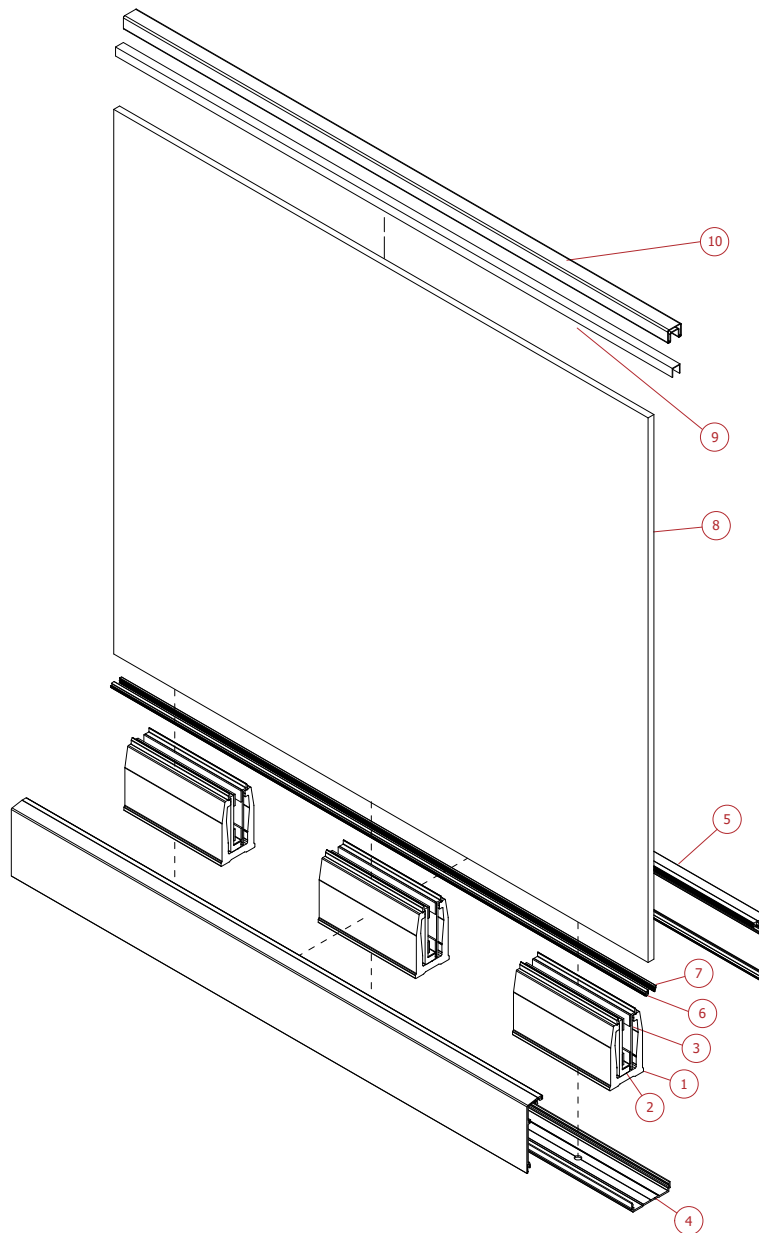

ITEM	Part Number	Description
1	AGM-00-020X	Structural block assembly for AZM2 system. Clamps glass to ABM-13R channel to vertically adjust when leveling
2	ABB	Bearing block. Part of AGM-00-020X
3	ABP	Bearing plate. Part of AGM-00-020X
4	ABM-13R	Pre-drilled alignment channel
5	AVM-13	Cover extrusion for on both sides
6	SRG40	Retained gasket, SRG40(12mm) - SRG30 (13.5mm & 14.28mm)/SRG20 (15mm)
7	SWE35	Wedge, SWE35(12mm) - SWE30 (13.5mm)/SWE25 (14.28mm & 15mm)
8	[Glass Infill]	Monolithic Toughened Safety Glass, Refer to Style Specification for appropriate thickness. Exposed edges Flat Polished.
9	ASG25-12	Polymer Gasket for Q25, suitable for 12mm glass
10	ARSQ25	Q25 Stainless Steel Top Rail 25 x 21mm

ASSEMBLY SPECIFICATIONS

NZBAL-D13.1 | SPEC ID **AS.60.19T**

'METROPOLIS' (Q40 STAINLESS STEEL TOP RAIL)

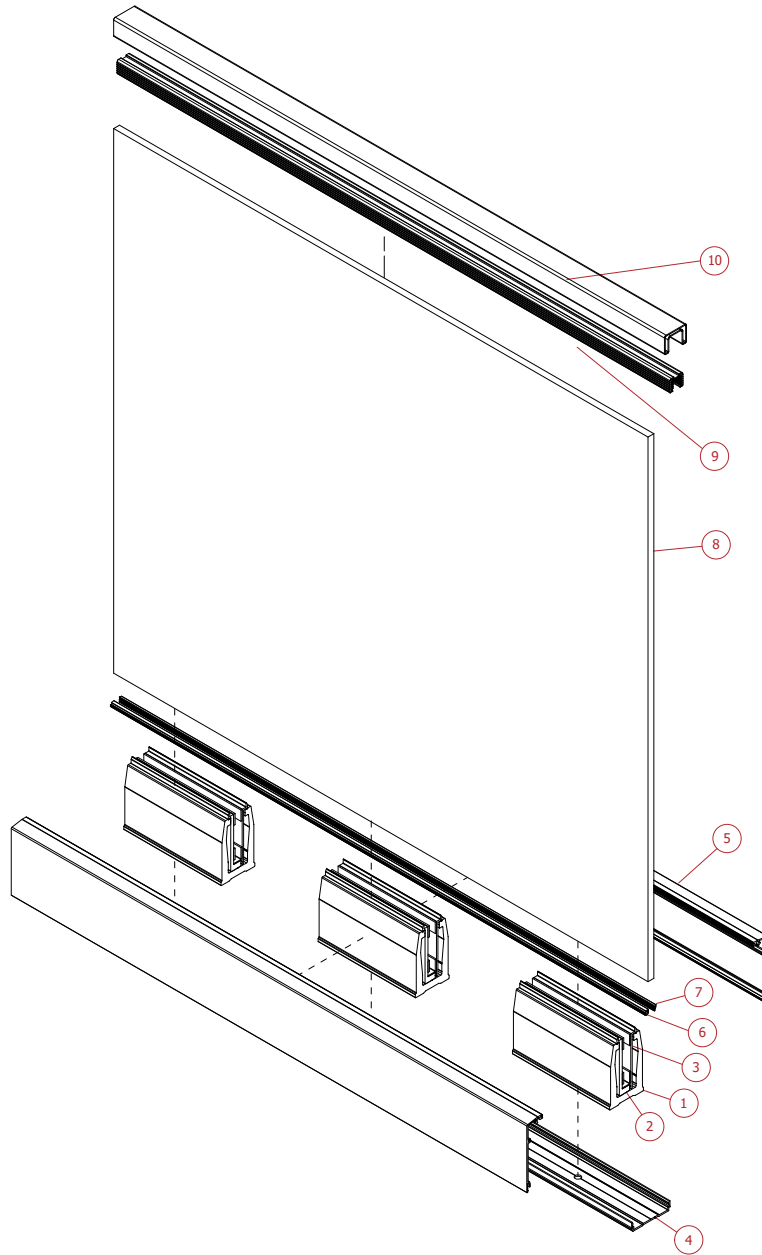

ITEM	Part Number	Description
1	AGM-00-020X	Structural block assembly for AZM2 system. Clamps glass to ABM-13R channel to vertically adjust when leveling
2	ABB	Bearing block. Part of AGM-00-020X
3	ABP	Bearing plate. Part of AGM-00-020X
4	ABM-13R	Pre-drilled alignment channel
5	AVM-13	Cover extrusion for on both sides
6	SRG40	Retained gasket, SRG40(12mm) - SRG30 (13.5mm & 14.28mm)/SRG20 (15mm)
7	SWE35	Wedge, SWE35(12mm) - SWE30 (13.5mm)/SWE25 (14.28mm & 15mm)
8	[Glass Infill]	Monolithic Toughened Safety Glass, Refer to Style Specification for appropriate thickness. Exposed edges Flat Polished.
9	ASG40-00-58	Rubber gasket for Q40.
10	ARSQ40	Q40 Stainless Steel Top Rail 40 x 30mm.

Specifications subject to change without notice

'METROPOLIS' (LRR SIDE RAIL)

Note: Side rail height shall not be less than the minimum barrier height, as required in F4/AS1.

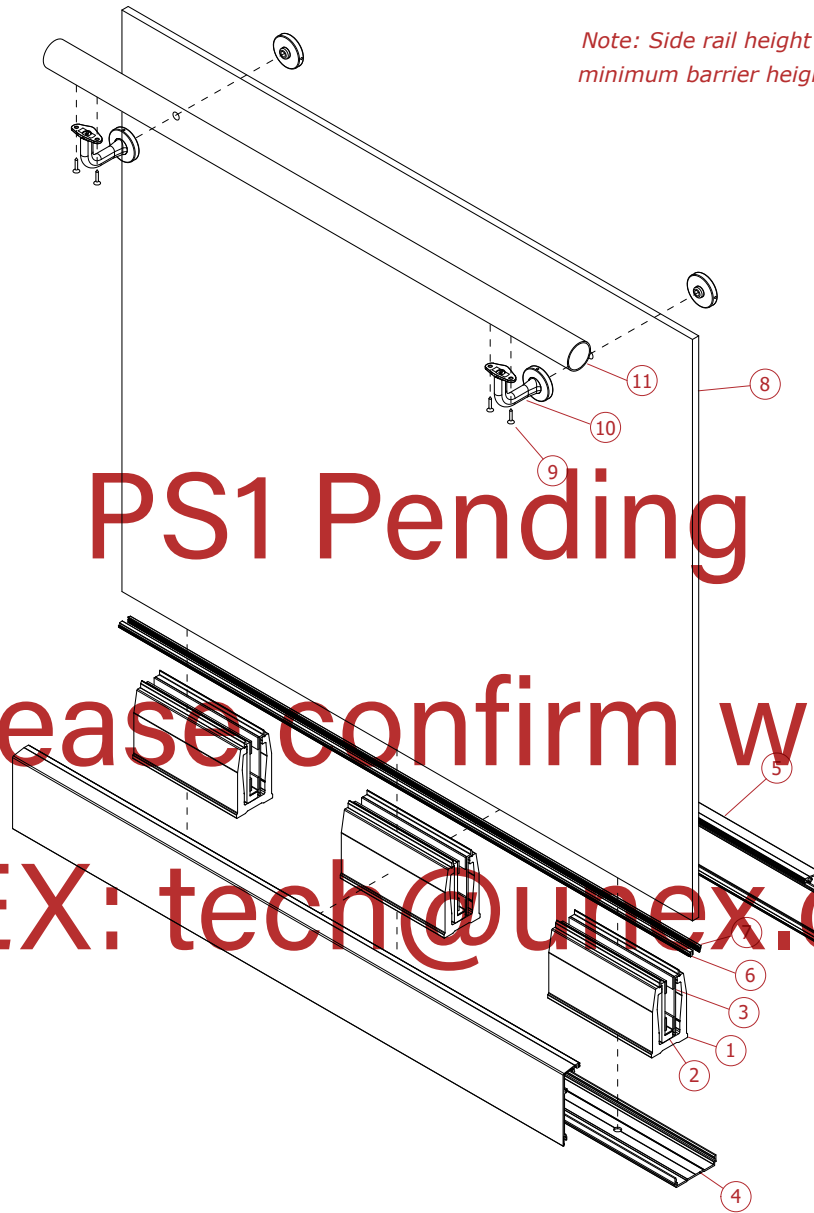

ITEM	Part Number	Description
1	AGM-00-020X	Structural block assembly for AZM2 system. Clamps glass to ABM-13R channel to vertically adjust when leveling
2	ABB	Bearing block. Part of AGM-00-020X
3	ABP	Bearing plate. Part of AGM-00-020X
4	ABM-13R	Pre-drilled alignment channel
5	AVM-13	Cover extrusion for on both sides
6	SRG40	Retained gasket, SRG40(12mm) - SRG30 (13.5mm & 14.28mm)/SRG20 (15mm)
7	SWE35	Wedge, SWE35(12mm) - SWE30 (13.5mm)/SWE25 (14.28mm & 15mm)
8	[Glass Infill]	Monolithic Toughened Safety Glass, Refer to Style Specification for appropriate thickness. Exposed edges Flat Polished.
9	FV10-19TR.T1	Self tapper screws. Drill size in DRH = Ø4.1mm.
10	LRWG	Side Rail bracket
11	LRR	Side Rail

ASSEMBLY SPECIFICATIONS

NZBAL-D13.1 | SPEC ID AS.61.00

'PANORAMA' (NO RAIL)

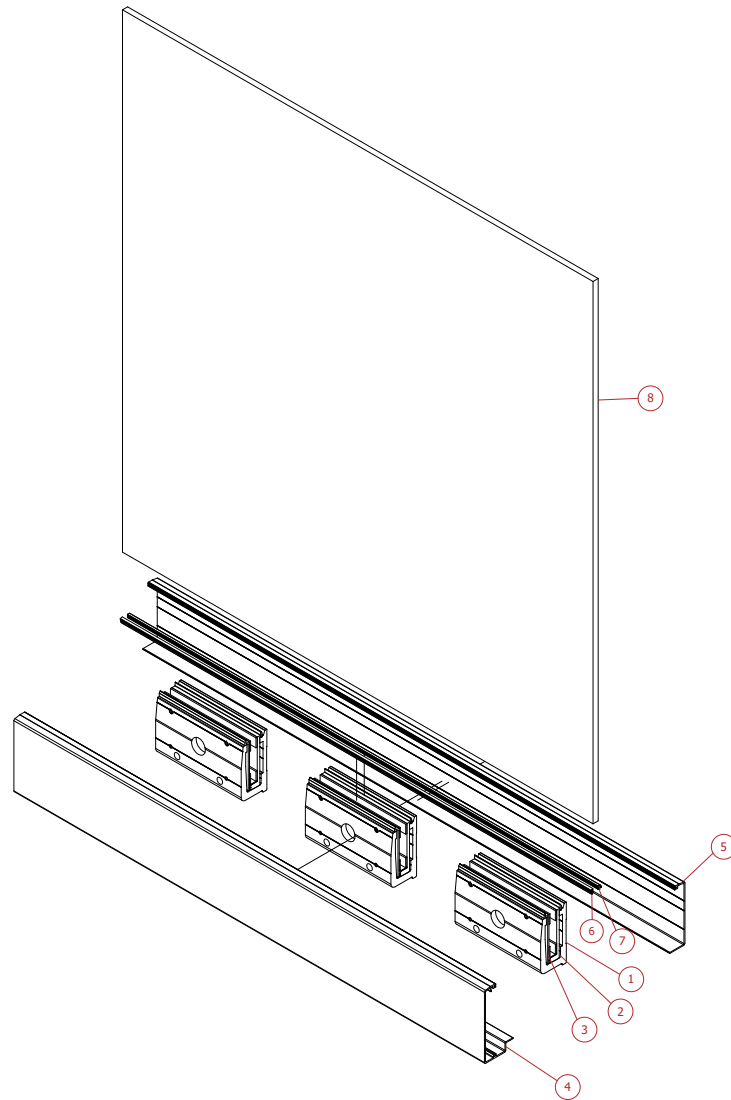

ITEM	Part Number	Description
1	AGS-00-020X	Structural block assembly for AZS3 system. Clamps glass to ABS150-13R channel to vertically adjust when leveling
2	ABB	Bearing block, part of AGS-00-020X
3	ABP	Bearing plate, part of AGS-00-020X
4	AVS150-13	Pre-drilled alignment backing channel/cover.
5	ABS150-13R	Cover extrusion, clips onto outside of AGS clamps.
6	SWE35	Wedge, SWE35(12mm) - SWE30 (13.5mm)/SWE25 (14.28mm & 15mm)/SWE20 (16.28mm)
7	SRG40	Retained gasket, SRG40(12mm) - SRG30 (13.5mm & 14.28mm)/SRG20 (15mm & 16.28mm)
8	[Glass Infill]	Toughened-Laminated Safety Glass with "SentryGlas" interlayer, Refer to the Style Specification for appropriate thickness. All exposed edges to be Flat Polished.

Specifications subject to change without notice

'PANORAMA' (VRR TOP RAIL)

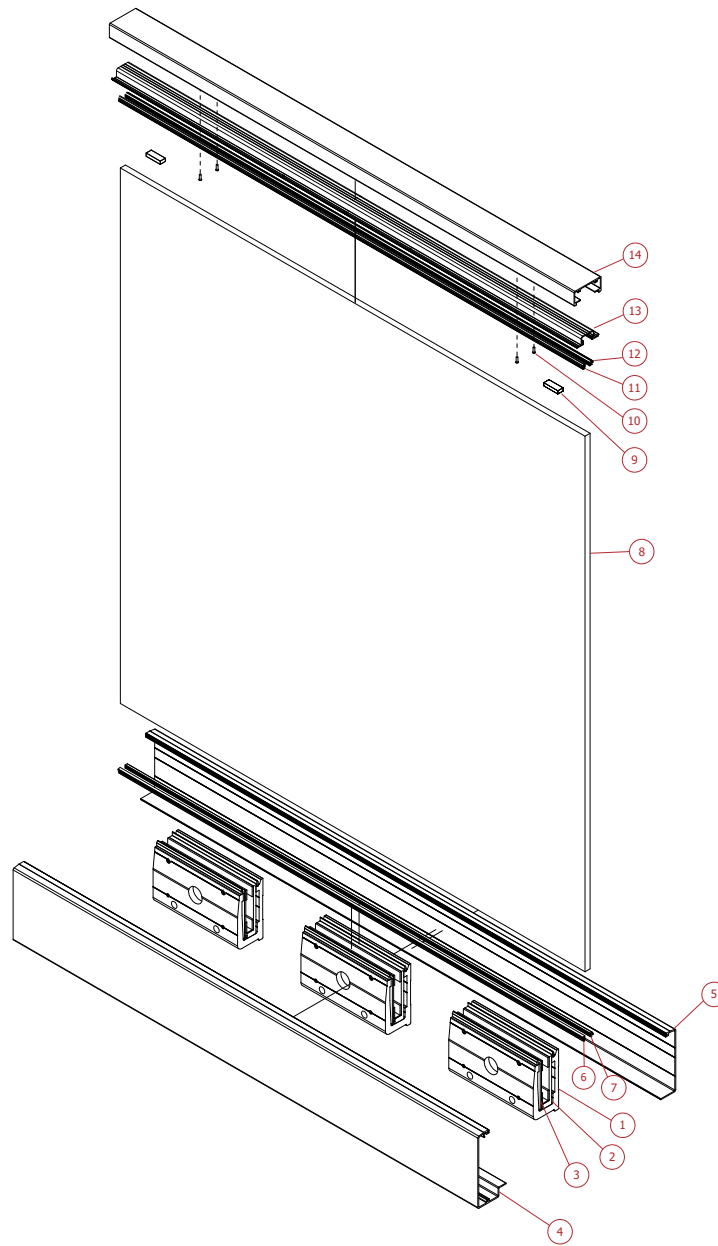

ITEM	Part Number	Description
1	AGS-00-020X	Structural block assembly for AZS3 system. Clamps glass to ABS150-13R channel to vertically adjust when leveling
2	ABB	Bearing block, part of AGS-00-020X
3	ABP	Bearing plate, part of AGS-00-020X
4	AVS150-13	Cover extrusion, clips onto outside of AGS clamps.
5	ABS150-13R	Pre-drilled alignment backing channel/cover.
6	SWE35	Wedge, SWE35(12mm) - SWE30 (13.5mm)/SWE25 (14.28mm & 15mm)/SWE20 (16.28mm)
7	SRG40	Retained gasket, SRG40(12mm) - SRG30 (13.5mm & 14.28mm)/SRG20 (15mm & 16.28mm)
8	[Glass Infill]	Monolithic Toughened Safety Glass. Refer to Style Specification for appropriate thickness. Exposed edges Flat Polished.
9	SBC	Setting blocks at 500mm centres to prevent over-compression of bonding silicone and protect glass during rail placement
10	FS4-4	Inner Rail rivets, 1 pair 150mm from ends and then 1000mm maximum centres between. Drill size = Ø3.3mm.
11	SRG40	Retained gasket, SRG40(12mm) - SRG30 (13.5mm & 14.28mm)/SRG20 (15mm & 16.28mm)
12	SWE35	Wedge, SWE35(12mm) - SWE30 (13.5mm)/SWE25 (14.28mm & 15mm)/SWE20 (16.28mm)
13	PZT	Inner Top Rail, Structural silicone bond to top edge of glass
14	VRR	Top Rail

ASSEMBLY SPECIFICATIONS

NZBAL-D13.1 | SPEC ID **AS.61.18T**

'PANORAMA' (Q25 STAINLESS STEEL TOP RAIL)

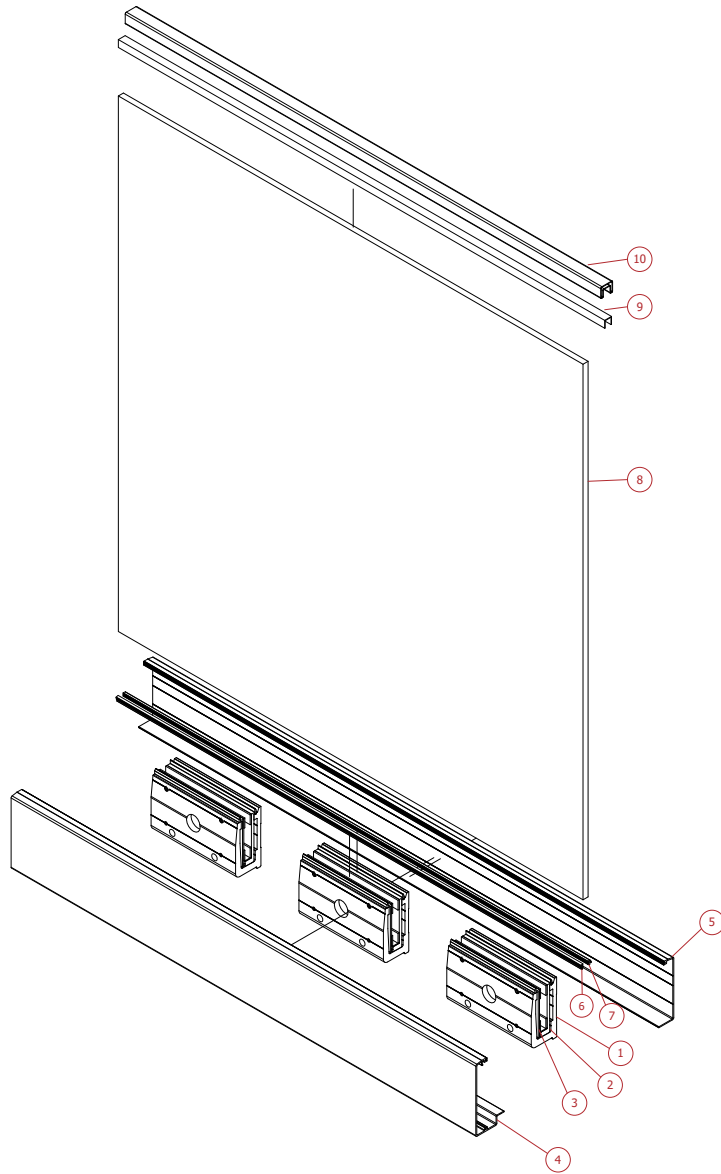

ITEM	Part Number	Description
1	AGS-00-020X	Structural block assembly for AZS3 system. Clamps glass to ABS150-13R channel to vertically adjust when leveling
2	ABB	Bearing block, part of AGS-00-020X
3	ABP	Bearing plate, part of AGS-00-020X
4	AVS150-13	Cover extrusion, clips onto outside of AGS clamps.
5	ABS150-13R	Pre-drilled alignment backing channel/cover.
6	SWE35	Wedge, SWE35(12mm) - SWE30 (13.5mm)/SWE25 (14.28mm & 15mm)/SWE20 (16.28mm)
7	SRG40	Retained gasket, SRG40(12mm) - SRG30 (13.5mm & 14.28mm)/SRG20 (15mm & 16.28mm)
8	[Glass Infill]	Monolithic Toughened Safety Glass, Refer to Style Specification for appropriate thickness. Exposed edges Flat Polished.
9	ASG25-12	Polymer Gasket for Q25, suitable for 12mm glass
10	ARSQ25	Q25 Stainless Steel Top Rail 25 x 21mm

Specifications subject to change without notice

'PANORAMA' (Q40 STAINLESS STEEL TOP RAIL)

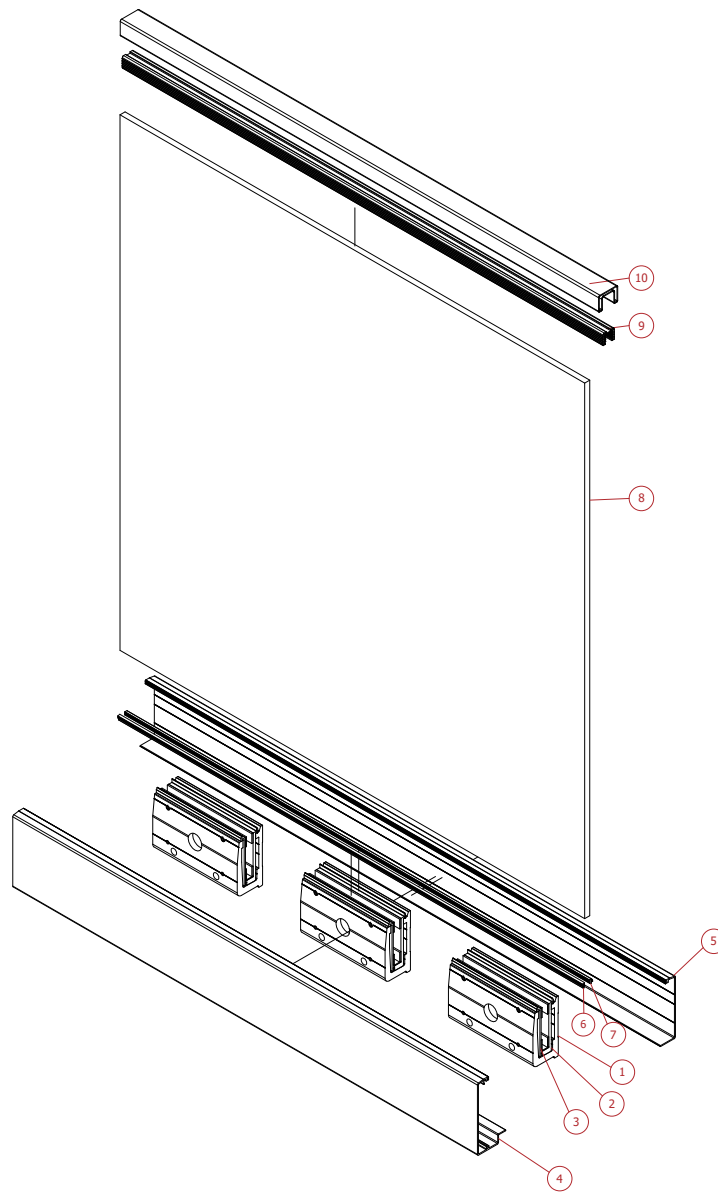

ITEM	Part Number	Description
1	AGS-00-020X	Structural block assembly for AZS3 system. Clamps glass to ABS150-13R channel to vertically adjust when leveling
2	ABB	Bearing block, part of AGS-00-020X
3	ABP	Bearing plate, part of AGS-00-020X
4	AVS150-13	Cover extrusion, clips onto outside of AGS clamps.
5	ABS150-13R	Pre-drilled alignment backing channel/cover.
6	SWE35	Wedge, SWE35(12mm) - SWE30 (13.5mm)/SWE25 (14.28mm & 15mm)/SWE20 (16.28mm)
7	SRG40	Retained gasket, SRG40(12mm) - SRG30 (13.5mm & 14.28mm)/SRG20 (15mm & 16.28mm)
8	[Glass Infill]	Monolithic Toughened Safety Glass, Refer to Style Specification for appropriate thickness. Exposed edges Flat Polished.
9	ASG40-00-58	Rubber gasket for Q40.
10	ARSQ40	Q40 Stainless Steel Top Rail 40 x 30mm.

ASSEMBLY SPECIFICATIONS

NZBAL-D13.1 | SPEC ID AS.61.20S

'PANORAMA' (STAINLESS STEEL SIDE RAIL*)

*44.5mm Ø x 1.5mm Wall Thickness Stainless Steel Circular Tube (Grade 316)

Note: Side rail height shall not be less than the minimum barrier height, as required in F4/AS1.

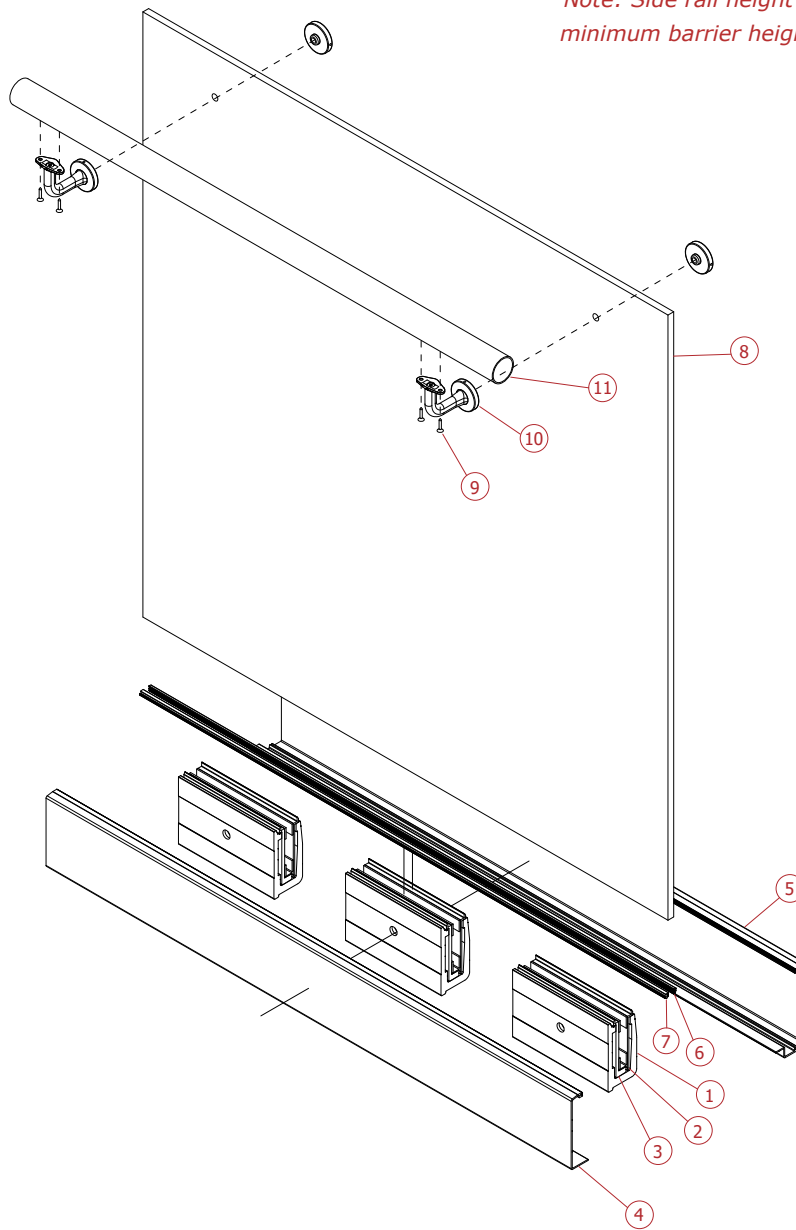

ITEM	Part Number	Description
1	AGS-00-020X	Structural block assembly for AZS3 system. Clamps glass to ABS150-13R channel to vertically adjust when leveling
2	ABP	Bearing plate, part of AGS-00-020X
3	ABB	Bearing block, part of AGS-00-020X
4	ABS150-13R	Pre-drilled alignment backing channel.
5	AVS150-13	Cover extrusion, clips onto outside of AGS clamps
6	SWE35	Wedge, SWE35(12mm) - SWE30 (13.5mm)/SWE25 (14.28mm & 15mm)/SWE20 (16.28mm)
7	SRG40	Retained gasket, SRG40(12mm) - SRG30 (13.5mm & 14.28mm)/SRG20 (15mm & 16.28mm)
8	[Glass Infill]	Monolithic Toughened Safety Glass, Refer to Style Specification for appropriate thickness. Exposed edges Flat Polished.
9	FV10-19TR.T1	Self tapper screws. Drill size in DRH = Ø4.1mm.
10	LRWG	Side Rail bracket
11	Side Rail	44.5mm Ø X 1.5mm Wall Thickness Stainless Steel Circular Tube (Grade 316)

Specifications subject to change without notice

'PANORAMA' (LRR SIDE RAIL)

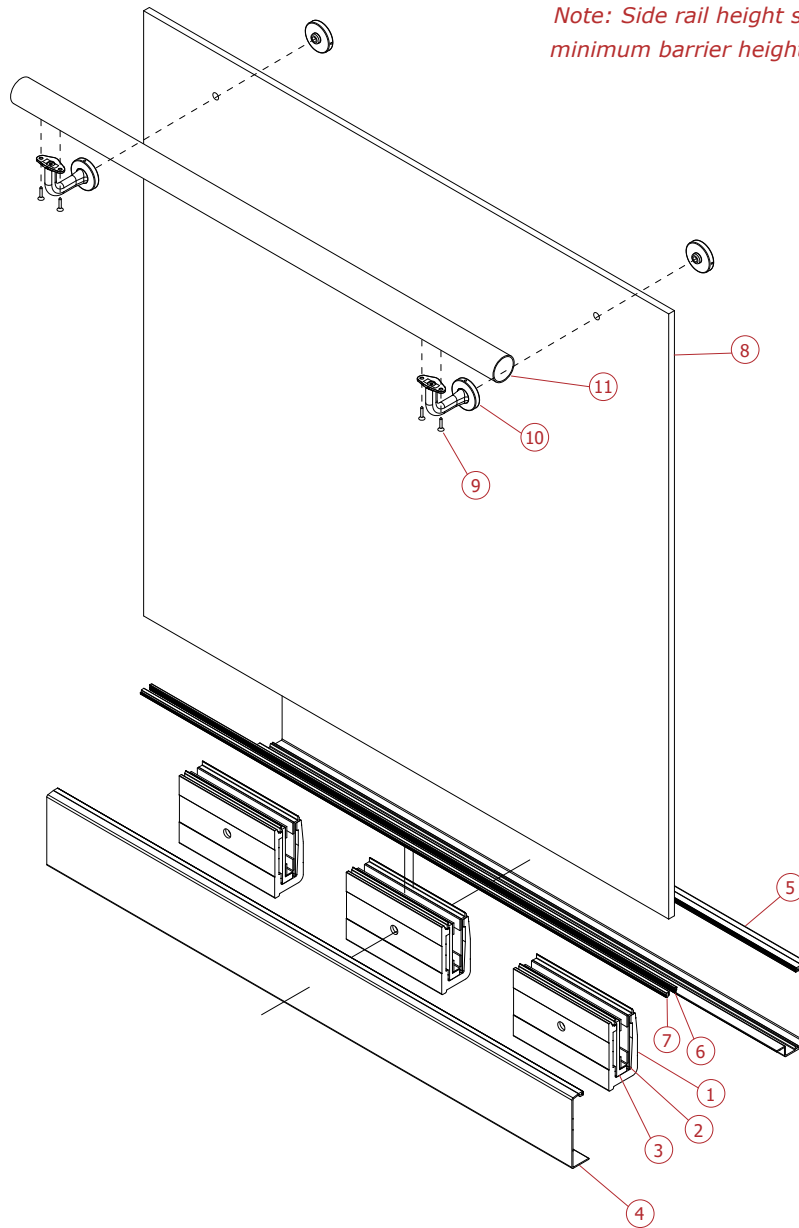

Note: Side rail height shall not be less than the minimum barrier height, as required in F4/AS1.

ITEM	Part Number	Description
1	AGS-00-020X	Structural block assembly for AZS3 system. Clamps glass to ABS150-13R channel to vertically adjust when leveling
2	ABP	Bearing plate, part of AGS-00-020X
3	ABB	Bearing block, part of AGS-00-020X
4	ABS150-13R	Pre-drilled alignment backing channel.
5	AVS150-13	Cover extrusion, clips onto outside of AGS clamps
6	SWE35	Wedge, SWE35(12mm) - SWE30 (13.5mm)/SWE25 (14.28mm & 15mm)/SWE20 (16.28mm)
7	SRG40	Retained gasket, SRG40(12mm) - SRG30 (13.5mm & 14.28mm)/SRG20 (15mm & 16.28mm)
8	[Glass Infill]	Monolithic Toughened Safety Glass, Refer to Style Specification for appropriate thickness. Exposed edges Flat Polished.
9	FV10-19TR.T1	Self tapper screws. Drill size in DRH = Ø4.1mm.
10	LRWG	Side Rail bracket
11	LRR	Side Rail

'ARENA-POINTS' (NO TOP RAIL)

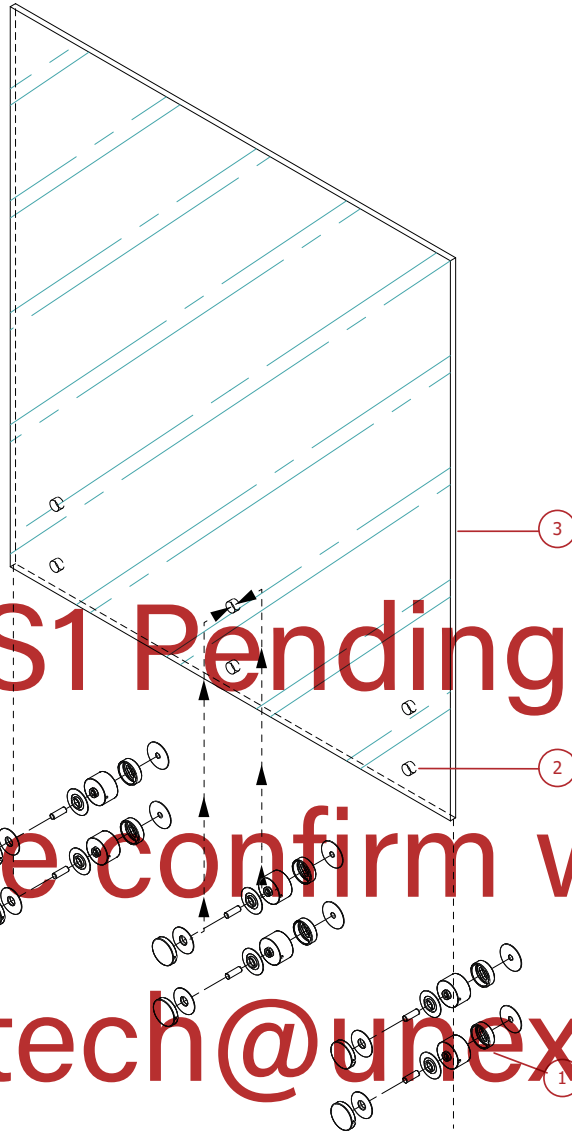

PS1 Pending

Please confirm with

UNEX: tech@unex.co.nz

ITEM	Part Number	Description
1	AJS5050DT	Aluminium or Stainless Steel Cap, FWBP49-16 Bushings, Spacer, and SGC49-10N Gasket Kits
2	[Hole Cutout]	Ø26mm hole
3	[Glass Infill]	Glass Panel, Refer to the Style Specification for appropriate thickness. All exposed edges to be Flat Polished.

'ARENA-POINTS' (VRR TOP RAIL)

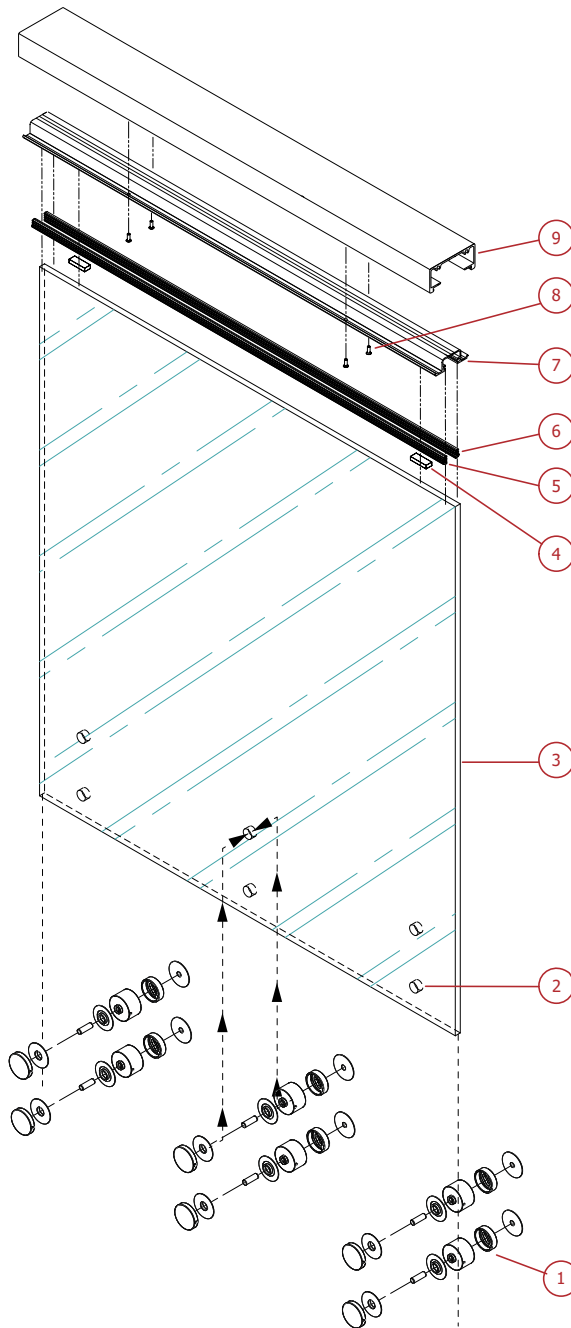

ITEM	Part Number	Description
1	AJS5050DT	Aluminium or Stainless Steel Cap, FWBP49-16 Bushings, Spacer, and SGC49-10N Gasket Kits
2	[Hole Cutout]	Ø26mm hole
3	[Glass Infill]	Glass Panel, Refer to the Style Specification for appropriate thickness. All exposed edges to be Flat Polished.
4	SBC	Setting blocks at 500mm centres to prevent over-compression of bonding silicone and protect glass during rail placement
5	SRG40	Retained gasket, SRG40(12mm) - SRG30 (13.5mm & 14.28mm)/SRG20 (15mm & 16.28mm)
6	SWE35	Wedge, SWE35(12mm) - SWE30 (13.5mm)/SWE25 (14.28mm & 15mm)/SWE20 (16.28mm)
7	PZT	Inner Top Rail, Structural silicone bond to top edge of glass
8	FS4-4	Inner Rail rivets, 1 pair 150mm from ends and then 1000mm maximum centres between. Drill size = Ø3.3mm.
9	VRR	Top Rail

ASSEMBLY SPECIFICATIONS

NZBAL-D14.0 | SPEC ID **AS.65.18T**

'ARENA-POINTS' (Q25 STAINLESS STEEL TOP RAIL)

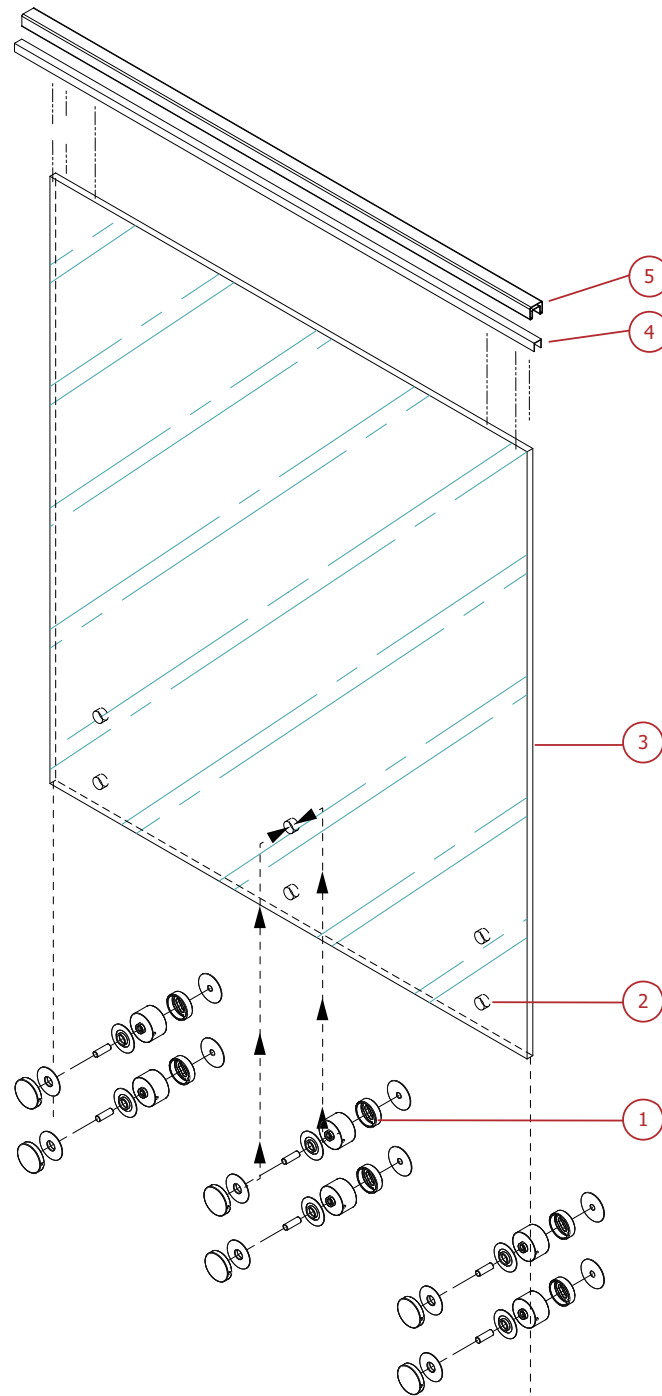

ITEM	Part Number	Description
1	AJS5050DT	Aluminium or Stainless Steel Cap, FWBP49-16 Bushings, Spacer, and SGC49-10N Gasket Kits
2	[Hole Cutout]	Ø26mm hole
3	[Glass Infill]	Glass Panel, Refer to the Style Specification for appropriate thickness. All exposed edges to be Flat Polished.
4	ASG25-12	Polymer Gasket for Q25, suitable for 12mm glass
5	ARSQ25	Q25 Stainless Steel Top Rail 25 x 21mm

Specifications subject to change without notice

'ARENA-POINTS' (Q40 STAINLESS STEEL TOP RAIL)

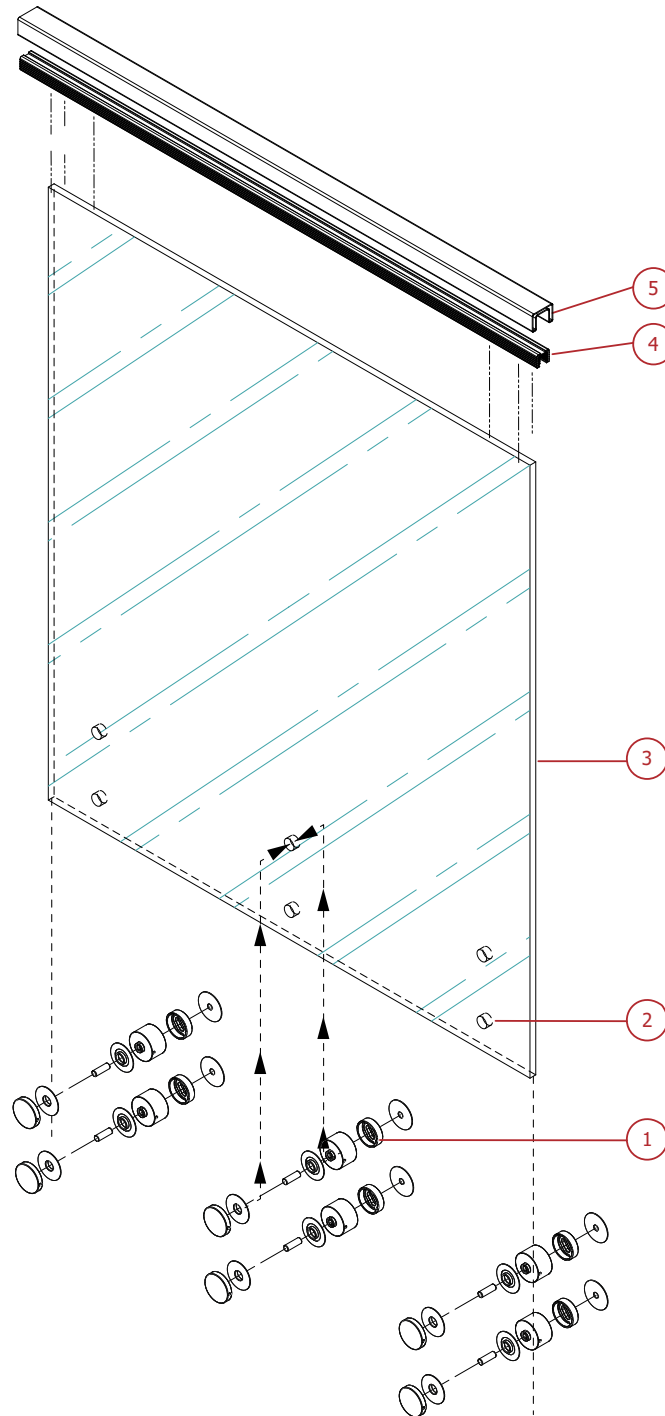

ITEM	Part Number	Description
1	AJS5050DT	Aluminium or Stainless Steel Cap, FWBP49-16 Bushings, Spacer, and SGC49-10N Gasket Kits
2	[Hole Cutout]	Ø26mm hole
3	[Glass Infill]	Glass Panel, Refer to the Style Specification for appropriate thickness. All exposed edges to be Flat Polished.
4	ASG40-00-58	Rubber gasket for Q40.
5	ARSQ40	Q40 Stainless Steel Top Rail 40 x 30mm.

ASSEMBLY SPECIFICATIONS

NZBAL-D14.0 | SPEC ID AS.65.12S

'ARENA-POINTS' (VRR SIDE RAIL)

Note: Side rail height shall not be less than the minimum barrier height, as required in F4/AS1.

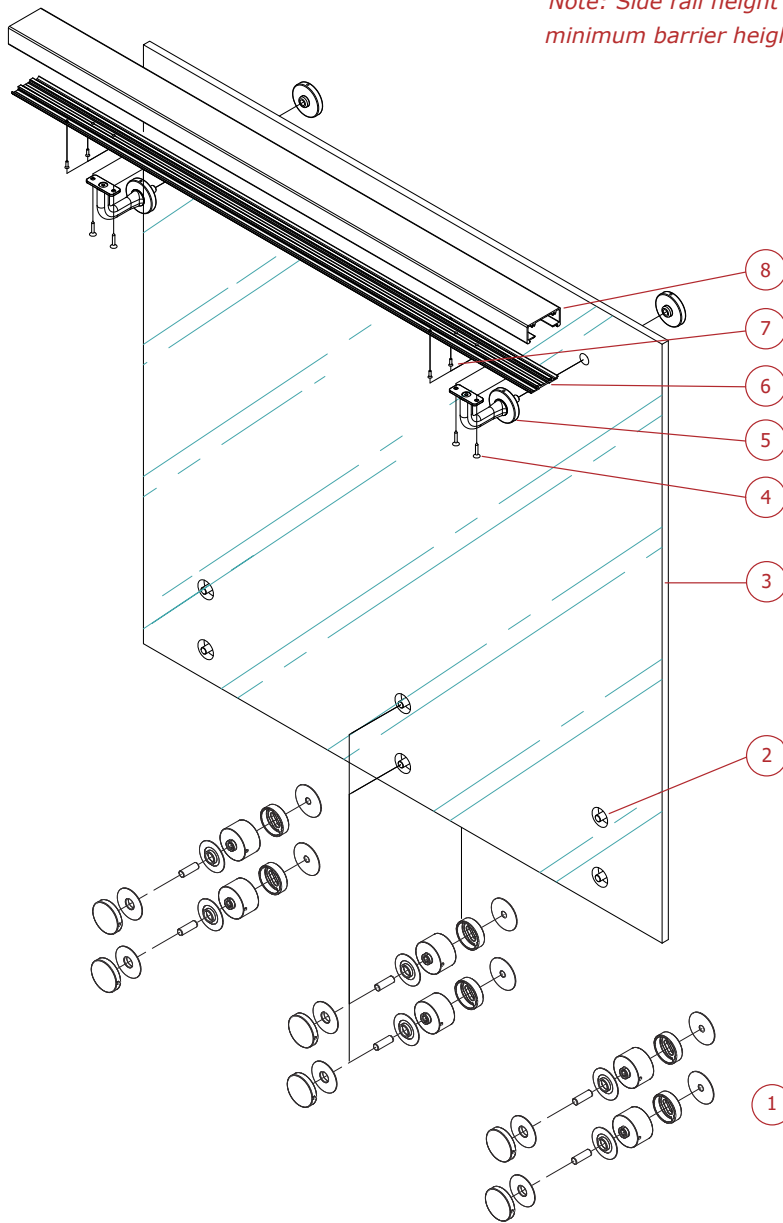

ITEM	Part Number	Description
1	AJS5050DT	Aluminium or Stainless Steel Cap, FWBP49-16 Bushing, Spacer, and SGC49-10N Gasket Kits
2	[Hole Cutout]	Ø26mm hole
3	[Glass Infill]	Glass Panel, Refer to the Style Specification for appropriate thickness. All exposed edges to be Flat Polished.
4	FV10-19TR.T1	Self tapper screw. Drill size = Ø4.1mm.
5	LBWG	Side Rail bracket
6	DRH	Inner Top Rail
7	FS4-4	Inner Rail rivets, 1 pair 150mm from ends and then 1000mm maximum centres between. Drill size = Ø3.3mm.
8	VRR	Side Rail

Specifications subject to change without notice

'ARENA-POINTS' (LRR SIDE RAIL)

Note: Side rail height shall not be less than the minimum barrier height, as required in F4/AS1.

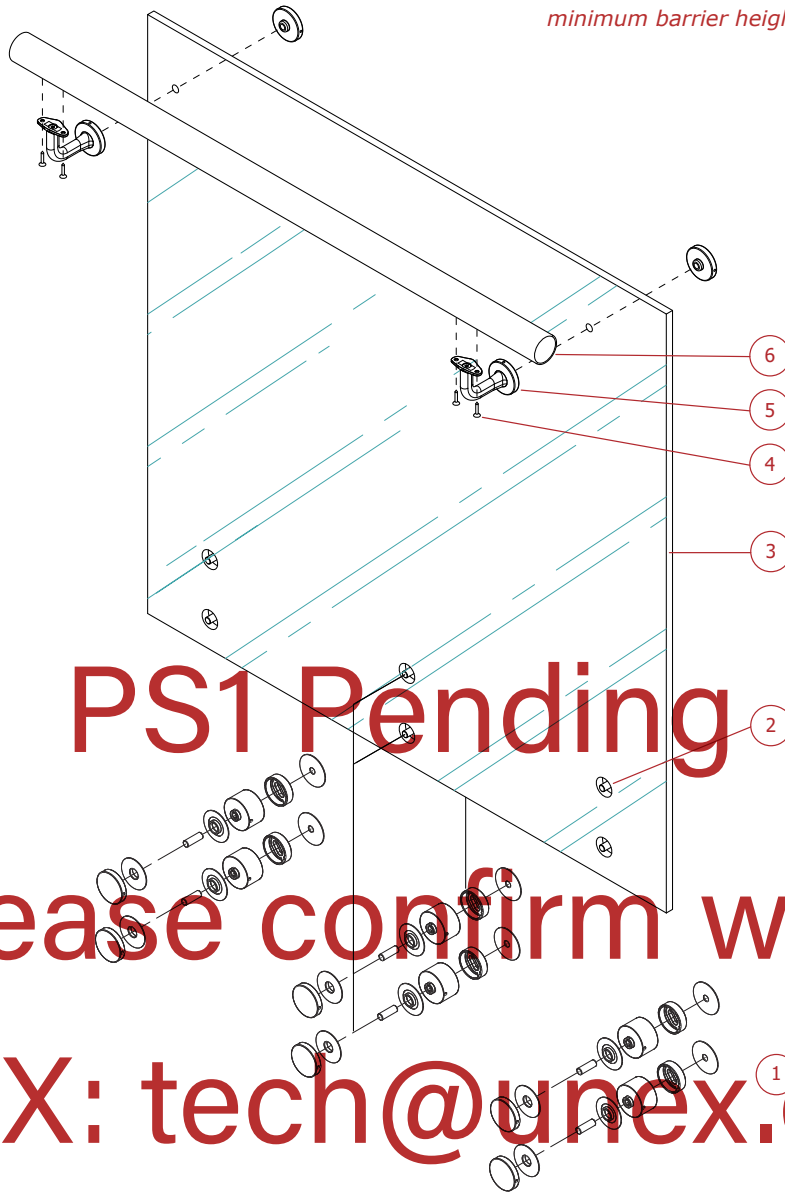

ITEM	Part Number	Description
1	AJS5050DT	Aluminium or Stainless Steel Cap, FWBP49-16 Bushing, Spacer, and SGC49-10N Gasket Kits
2	[Hole Cutout]	Ø26mm hole
3	[Glass Infill]	Glass Panel, Refer to the Style Specification for appropriate thickness. All exposed edges to be Flat Polished.
4	FV10-19TR.T1	Self tapper screw. Drill size = Ø4.1mm.
5	LRWG	Side Rail bracket
6	LRR	Side Rail

ASSEMBLY SPECIFICATIONS

NZBAL-D14.0 | SPEC ID **AS.66.00T**

'GLASSTRUT - TOP FIXED' (NO RAIL)

*Only applicable if NOT preventing a fall of 1.0m or more

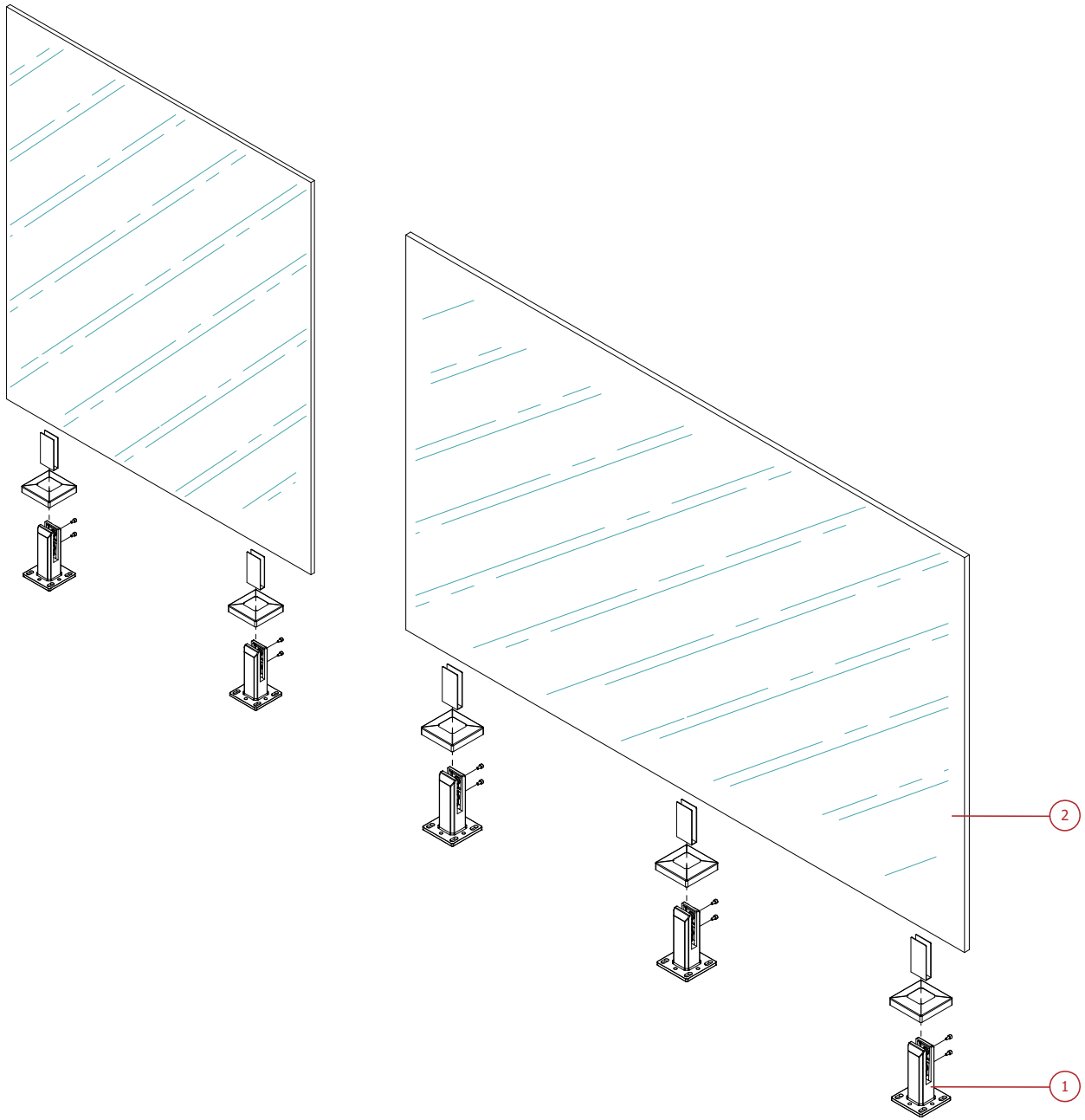

ITEM	Part Number	Description
1	AMQ1-12TJ.XX	Stainless Steel GlasStrut Top Mount Mini Post Kit
2	[Glass Infill]	Glass Panel, Refer to the Style Specification for appropriate thickness. All exposed edges to be Flat Polished.

Extrusions & Components

Style Specifications

Fixing Specifications

Assembly Specifications

Fabrication & Installation

'GLASSTRUT - TOP FIXED' (VRR TOP RAIL)

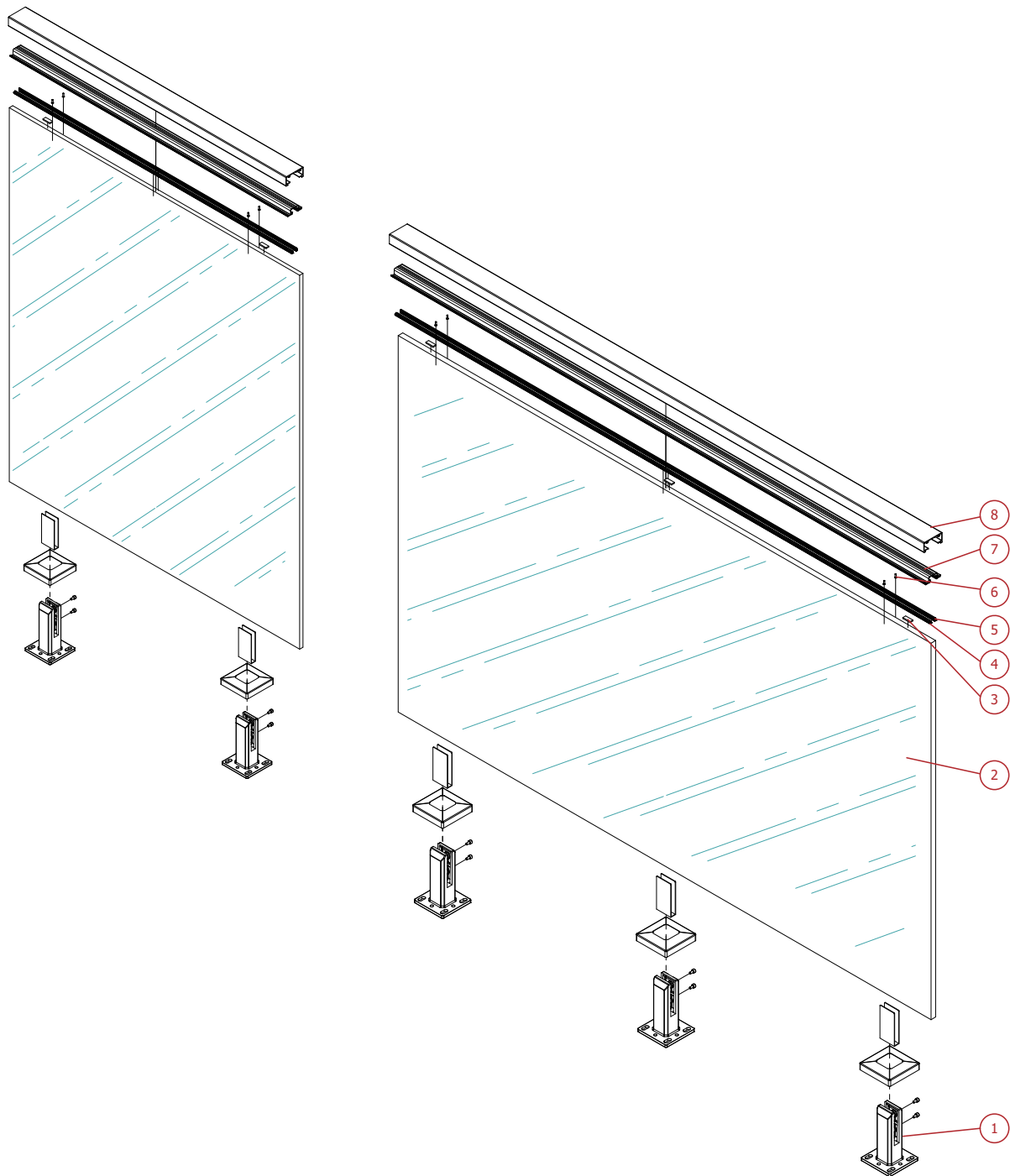

ITEM	Part Number	Description
1	AMQI-12TJ.XX	Stainless Steel GlasStrut Top Mount Mini Post Kit
2	[Glass Infill]	Glass Panel, Refer to the Style Specification for appropriate thickness. All exposed edges to be Flat Polished.
3	SBC	Setting blocks at 500mm centres to prevent over-compression of bonding silicone and protect glass during rail placement
4	SRG40	Retained gasket, SRG40(12mm) - SRG30 (13.5mm & 14.28mm)/SRG20 (15mm & 16.28mm)
5	SWE35	Wedge, SWE35(12mm) - SWE30 (13.5mm)/SWE25 (14.28mm & 15mm)/SWE20 (16.28mm)
6	FS4-4	Inner Rail rivets, 1 pair 150mm from ends and then 1000mm maximum centres between. Drill size = Ø3.3mm.
7	PZT	Inner Top Rail, Structural silicone bond to top edge of glass
8	VRR	Top Rail

ASSEMBLY SPECIFICATIONS

NZBAL-D14.0 | SPEC ID **AS.66.18T**

'GLASSTRUT - TOP FIXED' (Q25 STAINLESS STEEL TOP RAIL)

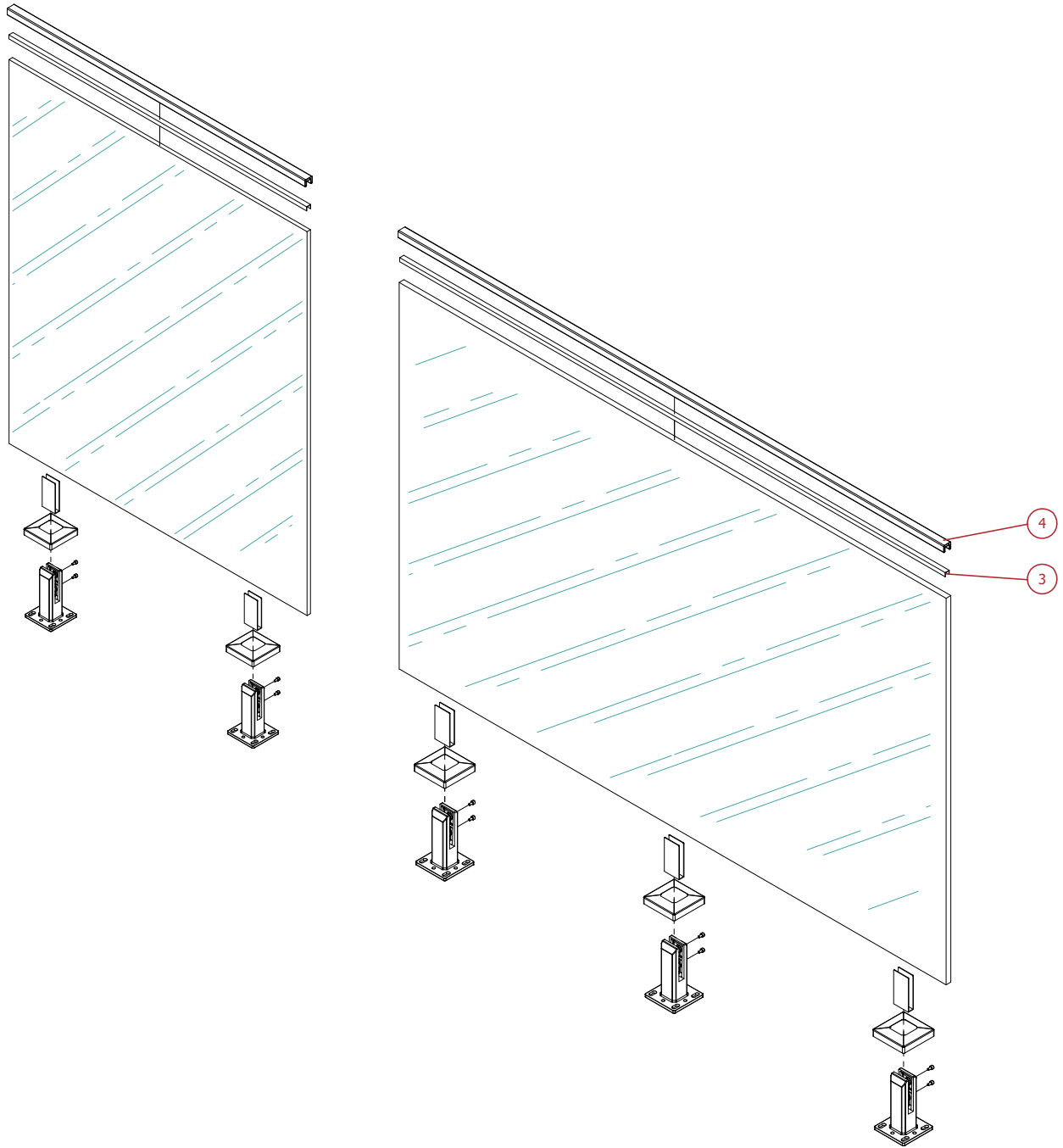

ITEM	Part Number	Description
1	AMQ1-12TJ.XX	Stainless Steel GlasStrut Top Mount Mini Post Kit
2	[Glass Infill]	Glass Panel, Refer to the Style Specification for appropriate thickness. All exposed edges to be Flat Polished.
3	ASG25-12	Polymer Gasket for Q25, suitable for 12mm glass
4	ARSQ25	Q25 Stainless Steel Top Rail 25 x 21mm

Specifications subject to change without notice

'GLASSTRUT - TOP FIXED' (Q40 STAINLESS STEEL TOP RAIL)

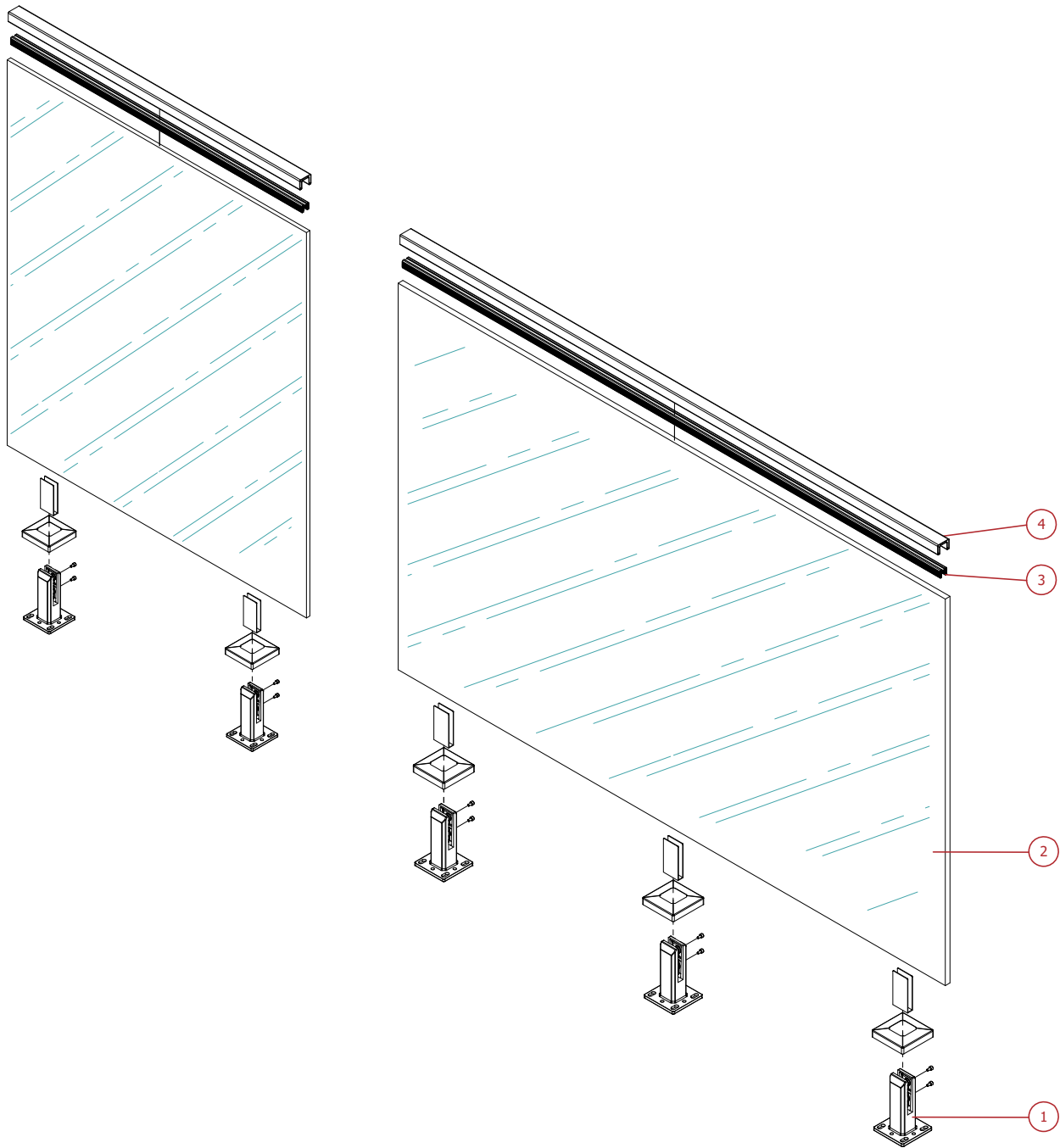

ITEM	Part Number	Description
1	AMQ1-12TJ.XX	Stainless Steel GlasStrut Top Mount Mini Post Kit
2	[Glass Infill]	Glass Panel, Refer to the Style Specification for appropriate thickness. All exposed edges to be Flat Polished.
3	ASG40-00-58	Rubber gasket for Q40.
4	ARSQ40	Q40 Stainless Steel Top Rail 40 x 30mm.

ASSEMBLY SPECIFICATIONS

NZBAL-D14.0 | SPEC ID **AS.67.00S**

'GLASSTRUT - SIDE FIXED' (NO RAIL)

*Only applicable if NOT preventing a fall of 1.0m or more

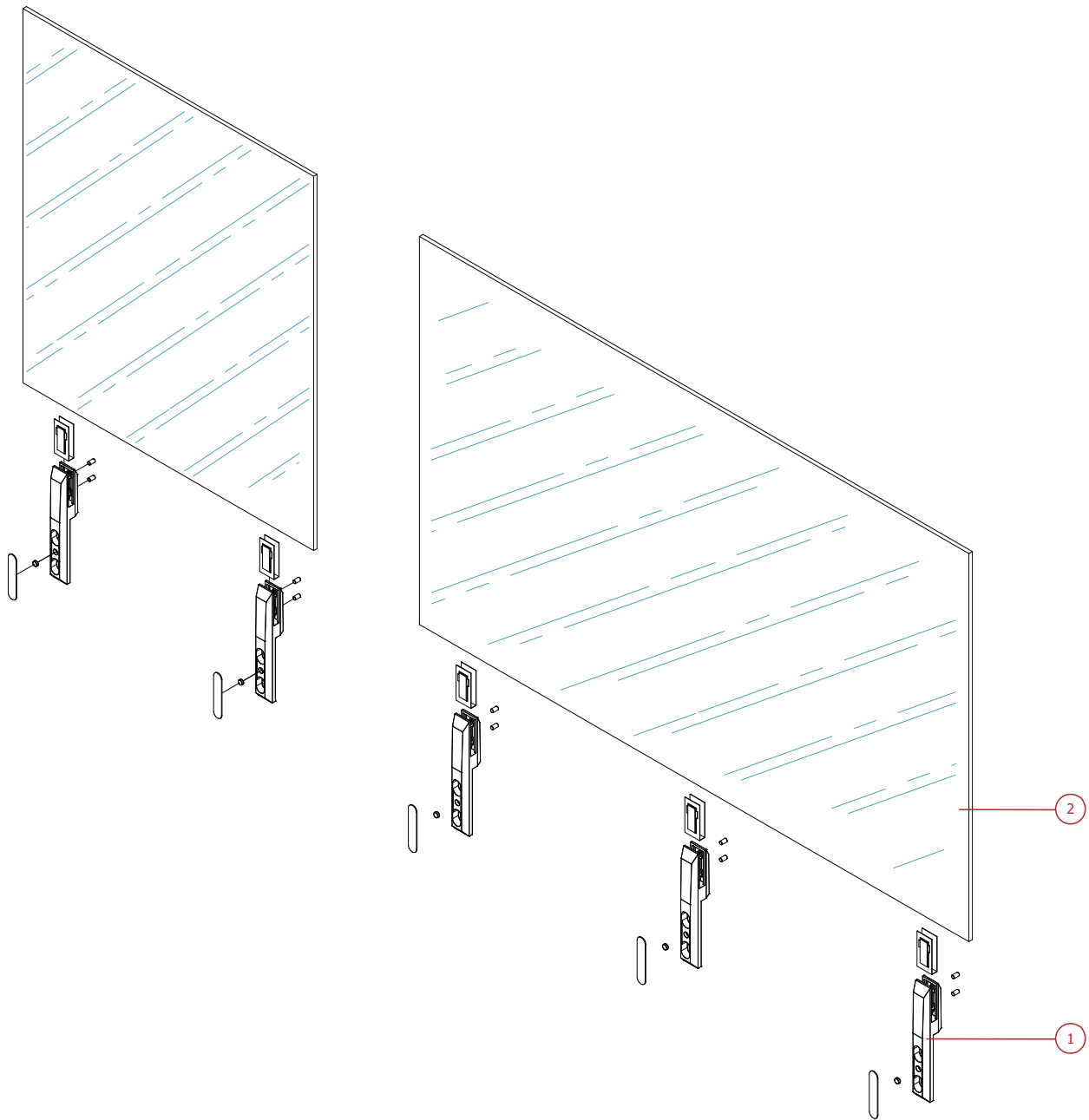

ITEM	Part Number	Description
1	AMQ1-12SF.XX	Stainless Steel GlasStrut Side Mount Mini Post
2	[Glass Infill]	Glass Panel, Refer to the Style Specification for appropriate thickness. All exposed edges to be Flat Polished.

Extrusions & Components

Style Specifications

Fixing Specifications

Assembly Specifications

Fabrication & Installation

'GLASSTRUT - SIDE FIXED' (VRR TOP RAIL)

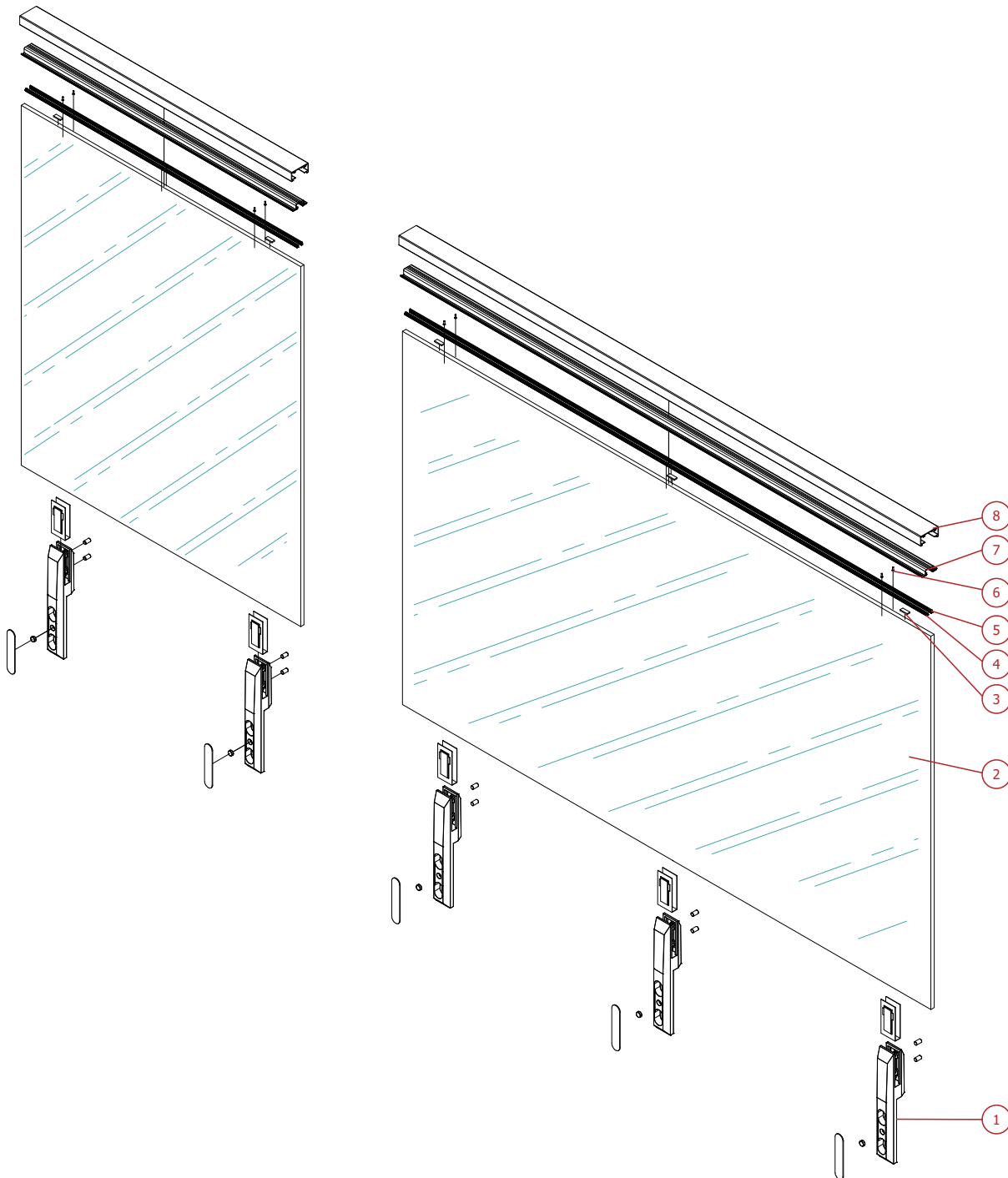

ITEM	Part Number	Description
1	AMQ1-12SF.XX	Stainless Steel GlasStrut Side Mount Mini Post
2	[Glass Infill]	Glass Panel, Refer to the Style Specification for appropriate thickness. All exposed edges to be Flat Polished.
3	SBC	Setting blocks at 500mm centres to prevent over-compression of bonding silicone and protect glass during rail placement
4	SRG40	Retained gasket, SRG40(12mm) - SRG30 (13.5mm & 14.28mm)/SRG20 (15mm & 16.28mm)
5	SWE35	Wedge, SWE35(12mm) - SWE30 (13.5mm)/SWE25 (14.28mm & 15mm)/SWE20 (16.28mm)
6	PZT	Inner Top Rail, Structural silicone bond to top edge of glass
7	FS4-4	Inner Rail rivets, 1 pair 150mm from ends and then 1000mm maximum centres between. Drill size = Ø3.3mm.
8	VRR	Top Rail

ASSEMBLY SPECIFICATIONS

NZBAL-D14.0 | SPEC ID **AS.67.18S**

'GLASSTRUT - SIDE FIXED' (Q25 STAINLESS STEEL TOP RAIL)

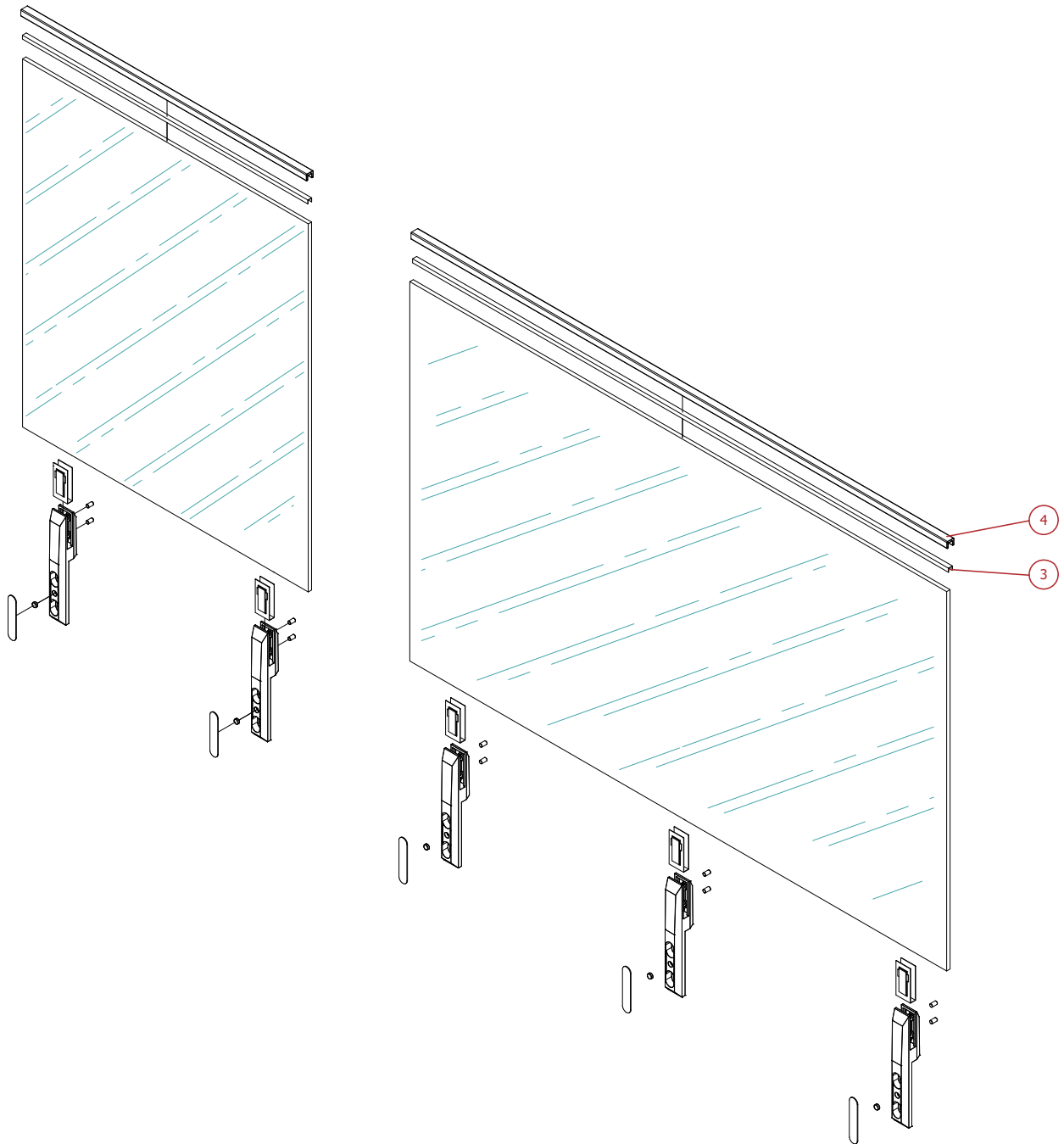

ITEM	Part Number	Description
1	AMQ1-12SF.XX	Stainless Steel GlasStrut Side Mount Mini Post
2	[Glass Infill]	Glass Panel, Refer to the Style Specification for appropriate thickness. All exposed edges to be Flat Polished.
3	ASG25-12	Polymer Gasket for Q25, suitable for 12mm glass
4	ARSQ25	Q25 Stainless Steel Top Rail 25 x 21mm

Specifications subject to change without notice

'GLASSTRUT - SIDE FIXED' (Q40 STAINLESS STEEL TOP RAIL)

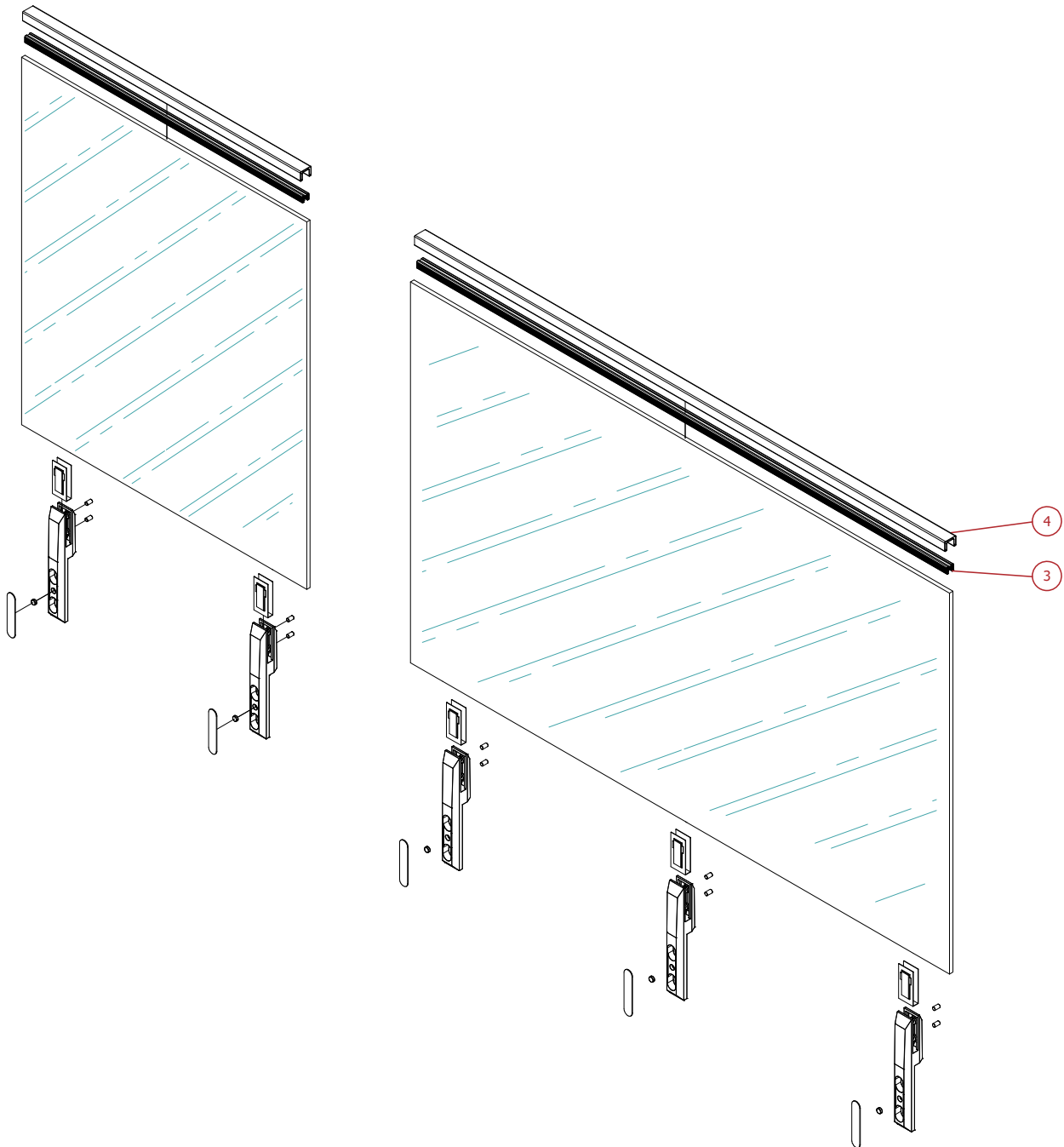

ITEM	Part Number	Description
1	AMQ1-12SF.XX	Stainless Steel GlasStrut Side Mount Mini Post
2	[Glass Infill]	Glass Panel, Refer to the Style Specification for appropriate thickness. All exposed edges to be Flat Polished.
3	ASG40-00-58	Rubber gasket for Q40.
4	ARSQ40	Q40 Stainless Steel Top Rail 40 x 30mm.

CHAPTER 5 - FRAMELESS GLASS FABRICATION & INSTALLATION

	Site measuring - General guide	129-130
Extrusions & Components	VD.60.00 'Metropolis' (NO Rail) - Vertical Dimensions	131
	VVD.60.12T 'Metropolis' (VRR Top Rail) - Vertical Dimensions	132
	VD.60.18T 'Metropolis' (Q25 Stainless Steel Top Rail) - Vertical Dimensions	133
	VD.60.19T 'Metropolis' (Q40 Stainless Steel Top Rail) - Vertical Dimensions	134
VD.60.14S 'Metropolis' (LRR Side Rail) - Vertical Dimensions	135	
Style Specifications	VD.61.00 'Panorama' (NO Rail) - Vertical Dimensions	136
	VD.61.12T 'Panorama' (VRR Top Rail) - Vertical Dimensions	137
	VD.61.18T 'Panorama' (Q25 Stainless Steel Top Rail) - Vertical Dimensions	138
	VD.61.19T 'Panorama' (Q40 Stainless Steel Top Rail) - Vertical Dimensions	139
	VD.61.14S 'Panorama' (LRR Side Rail) - Vertical Dimensions	140
	VD. 'Panorama' (Round Stainless Steel Side Rail) - Vertical Dimensions	141
	VD.65.00 'Arena-Points' (No Top Rail) - Vertical Dimensions	142
	VD.65.12T 'Arena-Points' (VRR Top Rail) - Vertical Dimensions	143
	VD.65.18T 'Arena-Points' (Q25 Stainless Steel Top Rail) - Vertical Dimensions	144
	VD.65.19T 'Arena-Points' (Q40 Stainless Steel Top Rail) - Vertical Dimensions	145
Fixing Specifications	VD.65.12S 'Arena-Points' (VRR Side Rail) - Vertical Dimensions	146
	VD.65.14S 'Arena-Points' (LRR Side Rail) - Vertical Dimensions	147
	VD.66.00T 'GlasStrut Top Fixed' (No Top Rail) - Vertical Dimensions	148
	VD.66.12T 'GlasStrut Top Fixed' (VRR Top Rail) - Vertical Dimensions	149
	VD.66.18T 'GlasStrut Top Fixed' (Q25 Stainless Steel Top Rail) - Vertical Dimensions	150
	VD.66.19T 'GlasStrut Top Fixed' (Q40 Stainless Steel Top Rail) - Vertical Dimensions	151
Assembly Specifications	VD.67.00S 'GlasStrut Side Fixed' (No Top Rail) - Vertical Dimensions	152
	VD.67.12S 'GlasStrut Top Fixed' (VRR Top Rail) - Vertical Dimensions	153
	VD.67.18S 'GlasStrut Top Fixed' (Q25 Stainless Steel Top Rail) - Vertical Dimensions	154
	VD.67.19S 'GlasStrut Top Fixed' (Q40 Stainless Steel Top Rail) - Vertical Dimensions	155
Durability	156-157	
Epoxy-set anchor studs - Installation specification	158	
Fabrication & Installation guide for 'Metropolis' style balustrades	159-162	
Fabrication & Installation guide for 'Panorama' style balustrades	163-167	
Fabrication & Installation guide for 'Arena-Points' style balustrades	168-170	
Fabrication & Installation guide for 'GlasStrut' style balustrades	171-174	
UNEX Loading Classification	175	

SITE MEASURING - GENERAL GUIDE

The following guide applies specifically to site measuring which should show the 4 types of information described below, plus any other relevant data.

1. PLAN DIMENSIONS

To manufacture a balustrade, the fabricator will need to accurately know the centreline length of the balustrade, and the angle between each run at all corners. Obtaining this centreline length can be achieved by two methods, i.e. "ON-SITE" METHOD, whereby the centreline length is obtained direct from measurements on site; and the "CALCULATION" METHOD, whereby the centreline length is calculated from the deck edge measurements and angles. Below are the procedures for each method. NOTE: the "CALCULATION" METHOD is recommended for all balustrades that are side fixed to the balcony.

(i) "ON-SITE" METHOD: It is essential when using this method that the fixing method and baseplate type etc have been finalised. The balustrade centreline can then be marked at an appropriate distance back from the deck edge, ensuring that the fixings will engage with structural joists and nogs on timber decks, or that the fixings will not be less than the minimum edge distance specified for concrete decks. A chalk-line can be useful for marking out the balustrade centreline on the deck. Once this is done, the balustrade centreline lengths can be measured and recorded on a layout plan, along with the angles at all intersection points.

The advantage of this method is that measurements are directly available for the balustrade manufacture, without the need of further calculations, and therefore reducing risk of error etc.

(ii) "CALCULATION" METHOD: Measure and record the length of all deck edges which require balustrades, along with Substrate Details as described on Page 164

Once the fixing method and baseplate type has been finalised, the balustrade centreline "setback" dimension can also be finalised (i.e. the distance the balustrade centreline is set back from the deck edge). Consequent to this, the balustrade centreline length can be calculated.

Where the deck angles are 90 degrees, this can be done by adding or subtracting the set-backs at each end of the run from the deck edge dimension. For other deck angles, a full size or scale drawing may be required to determine the amount to be added or subtracted to each end.

This method of site measuring will need to be used for side fixed balustrades.

At ends, carefully record all relevant details, such as: where measurements are to, the presence of doors or windows etc. Figure 1 shows a typical layout plan and dimensions.

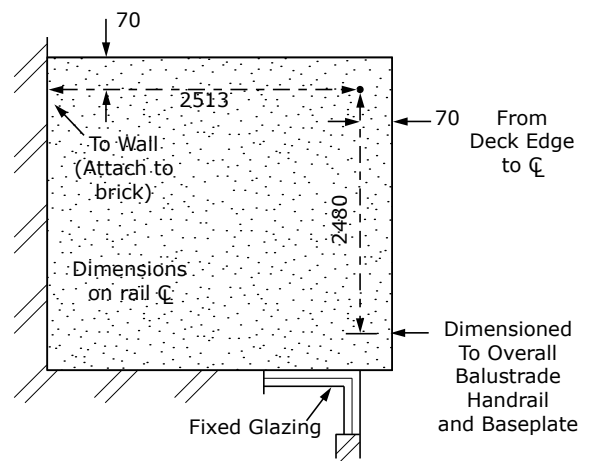

FIG. 1

(continued on following Page)

SITE MEASURING - GENERAL GUIDE - (CONT'D)

2. SUBSTRATE DETAILS

These describe the building structure at all points to which the balustrade attaches. Generally the best presentation of deck structure is given by dimensioned cross-sections of the deck edges; See Figure 2 for a typical cross-section.

Where attaching to walls or columns, ensure adequate solid fixing is available. Check these surfaces for plumb, and record any discrepancy.

3. CORNER ANGLES

On the layout plan, record the angles of all the corners. Measure these angles using an electronic protractor or similar.

If such an instrument is not available the angle can be determined by measuring a fixed amount (say 500mm) from the corner along both deck edges, marking these points and measuring the distance between them. By recording all three dimensions, the deck angle can then be accurately reproduced in the factory when fabricating the balustrade. Figure 3 shows various methods of recording the corner angle measurements.

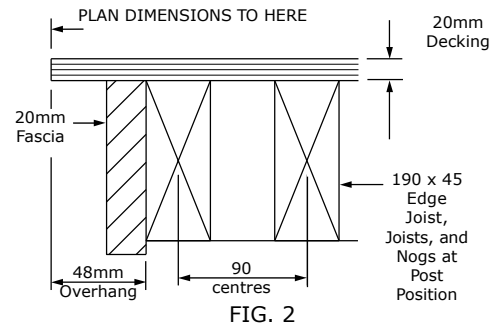

FIG. 2

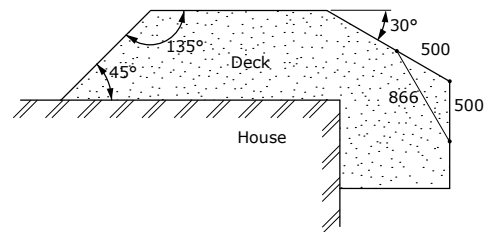

FIG. 3

4. CHANGES IN LEVEL

Note and record all changes in level.

- (i) MAJOR CHANGES, e.g.-Steps or ramps.
- (ii) MINOR CHANGES, e.g.-due to fall, sag in the deck or to general unevenness. These should be allowed for by varying each post length to obtain a straight and level top rail with the minimum specified rail height at the highest point in the deck. This generally necessitates a check on the deck level at every post position, as apparently flat decks can have significant variations in level.

The relative level of different post positions on the deck can be determined with a builders level and staff. Ensure that the zero end of the staff is on the deck. By reading on the staff the distance from the deck to the line of sight of the instrument, and recording at each position, the required length of each post can be determined.

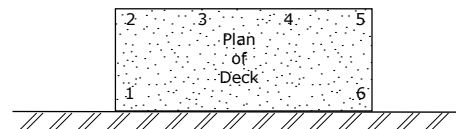

Point	Staff Reading
1	1500
2	1525
3	1520
4	1517
5	1522
6	1495

FIG. 4

The same procedure can be carried out using a laser level to provide the horizontal line of sight. It is convenient to identify each post position on the layout plan with a number, i.e. 1, 2, 3 etc, and show the staff readings in a table adjacent to each post reference. See Figure 4. In this example, Point 6 is the highest point on the deck, and Point 2 is the lowest, with a difference of 30mm.

'METROPOLIS' (NO RAIL) - VERTICAL DIMENSIONS

'METROPOLIS' (NO RAIL) - VERTICAL DIMENSIONS ⁽¹⁾					
DIMENSION	FORMULA	TYPICAL VALUES (mm)			
HEIGHT ⁽²⁾	(H)	As specified	1000	1100	1200
GLASS HEIGHT	(GH)	H-29	971	1071	1171

1. This table applies only with the use of the parts specified below.
 2. The typical heights used assume that the Glazing Channel is affixed to the top of the deck surface.
 3. Minor dimensions on the drawings have been rounded to the nearest millimetre.

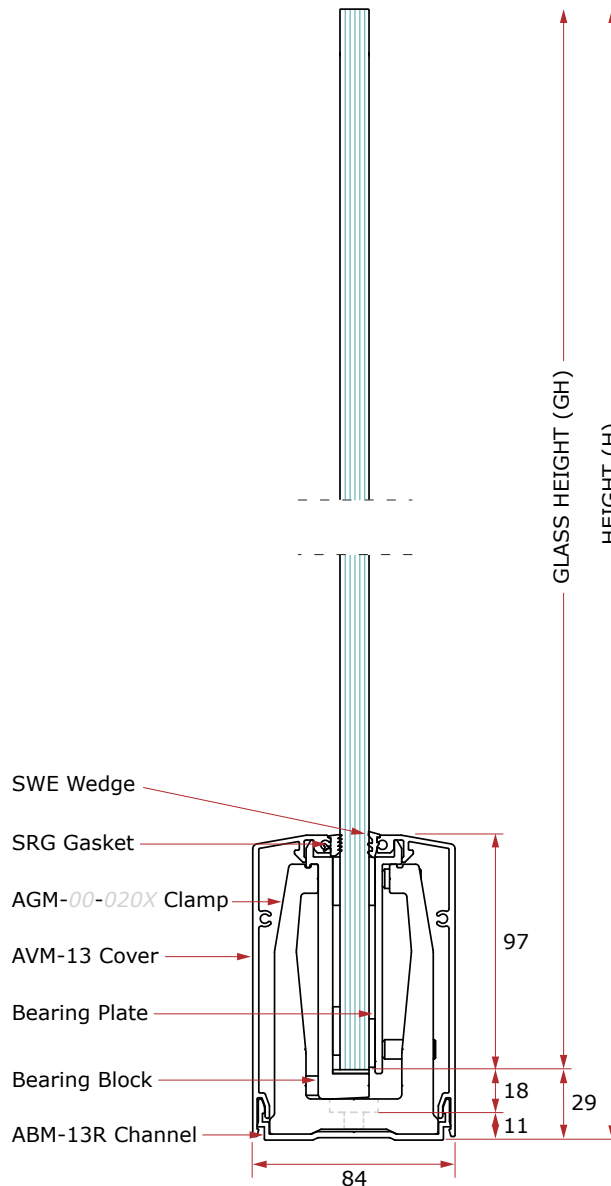
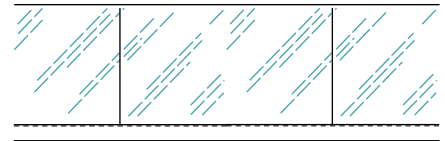

Extrusions & Components

Style Specifications

Fixing Specifications

Assembly Specifications

Fabrication & Installation

FABRICATION & INSTALLATION

SPEC ID **VD.60.12T** | **NZBAL-D13.1**

'METROPOLIS' (VRR TOP RAIL) VERTICAL DIMENSIONS

'METROPOLIS' (VRR TOP RAIL) - VERTICAL DIMENSIONS ⁽¹⁾					
DIMENSION	FORMULA	TYPICAL VALUES (mm)			
HEIGHT ⁽²⁾	(H)	As specified	1000	1100	1200
GLASS HEIGHT	(GH)	H-45	955	1055	1155

1. This table applies only with the use of the parts specified below.
2. The typical heights used assume that the Glazing Channel is affixed to the top of the deck surface.
3. Minor dimensions on the drawings have been rounded to the nearest millimetre.

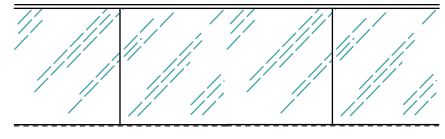

This is a guide for recommended cutting dimensions using the typical extrusions and components illustrated; use of others may require adjustments to the formulae and dimensions given here.

REFER TO THE Assembly Specification FOR FURTHER DETAILS

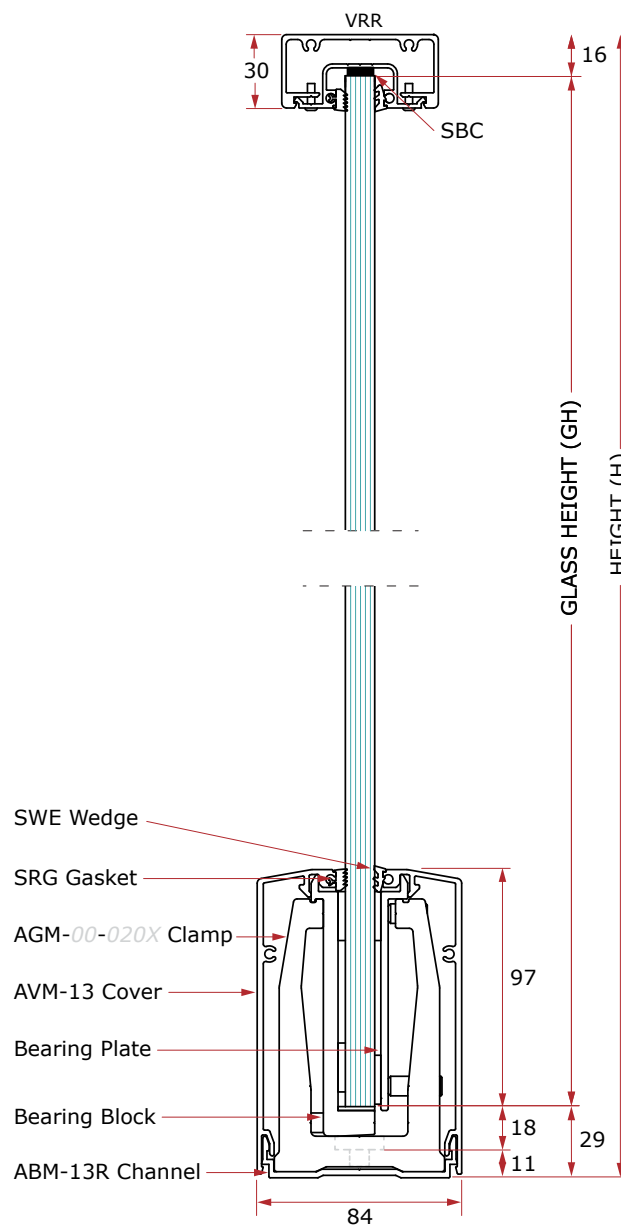

Extrusions & Components

Style Specifications

Fixing Specifications

Assembly Specifications

Fabrication & Installation

'METROPOLIS' (Q25 STAINLESS STEEL TOP RAIL) VERTICAL DIMENSIONS

'METROPOLIS' (Q25 TOP RAIL) - VERTICAL DIMENSIONS ⁽¹⁾					
DIMENSION	FORMULA	TYPICAL VALUES (mm)			
HEIGHT ⁽²⁾	(H)	As specified	1000	1100	1200
GLASS HEIGHT	(GH)	H-38	962	1062	1162

1. This table applies only with the use of the parts specified below.
 2. The typical heights used assume that the Glazing Channel is affixed to the top of the deck surface.
 3. Minor dimensions on the drawings have been rounded to the nearest millimetre.

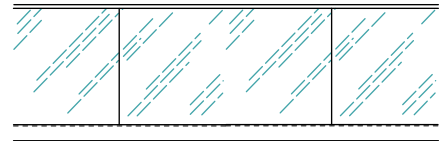

This is a guide for recommended cutting dimensions using the typical extrusions and components illustrated; use of others may require adjustments to the formulae and dimensions given here.

REFER TO THE Assembly Specification FOR FURTHER DETAILS

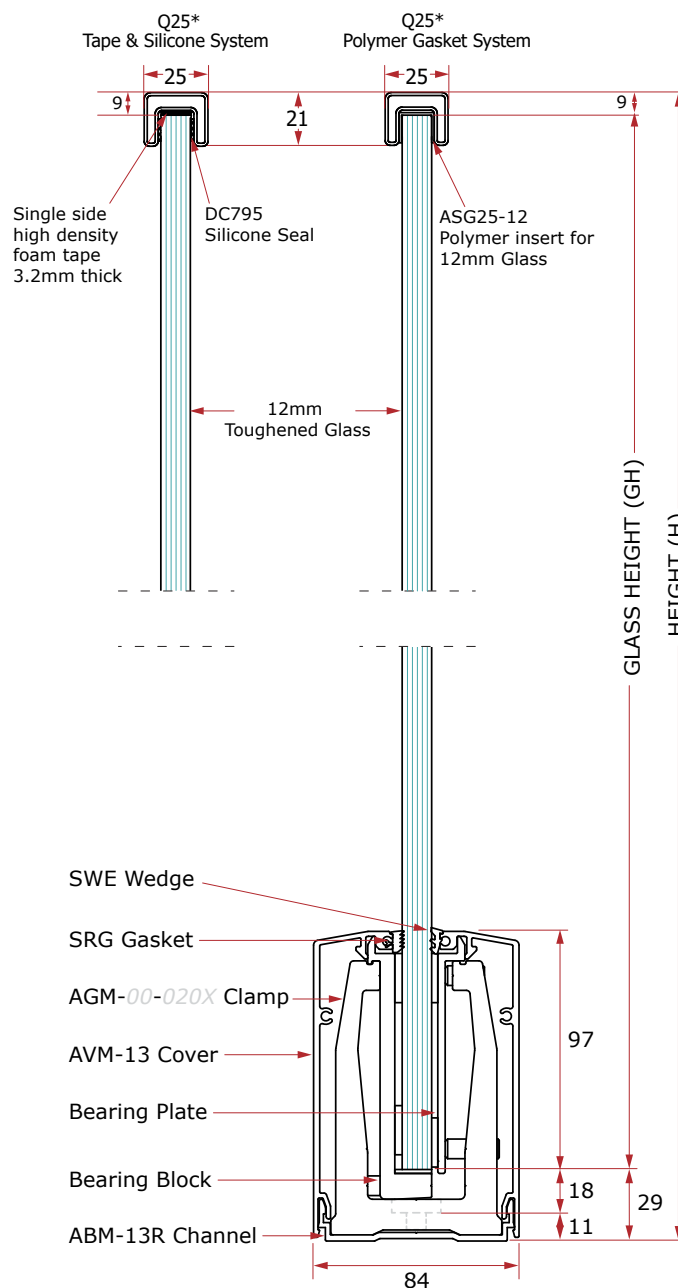

'METROPOLIS' (Q40 STAINLESS STEEL TOP RAIL) VERTICAL DIMENSIONS

'METROPOLIS' (Q40 TOP RAIL) - VERTICAL DIMENSIONS ⁽¹⁾					
DIMENSION	FORMULA	TYPICAL VALUES (mm)			
HEIGHT ⁽²⁾	(H)	As specified	1000	1100	1200
GLASS HEIGHT	(GH)	H-38	962	1062	1162

1. This table applies only with the use of the parts specified below.
 2. The typical heights used assume that the Glazing Channel is affixed to the top of the deck surface.
 3. Minor dimensions on the drawings have been rounded to the nearest millimetre.

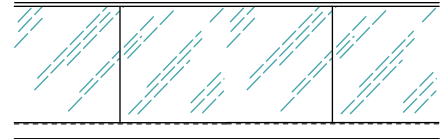

This is a guide for recommended cutting dimensions using the typical extrusions and components illustrated; use of others may require adjustments to the formulae and dimensions given here.

REFER TO THE Assembly Specification FOR FURTHER DETAILS

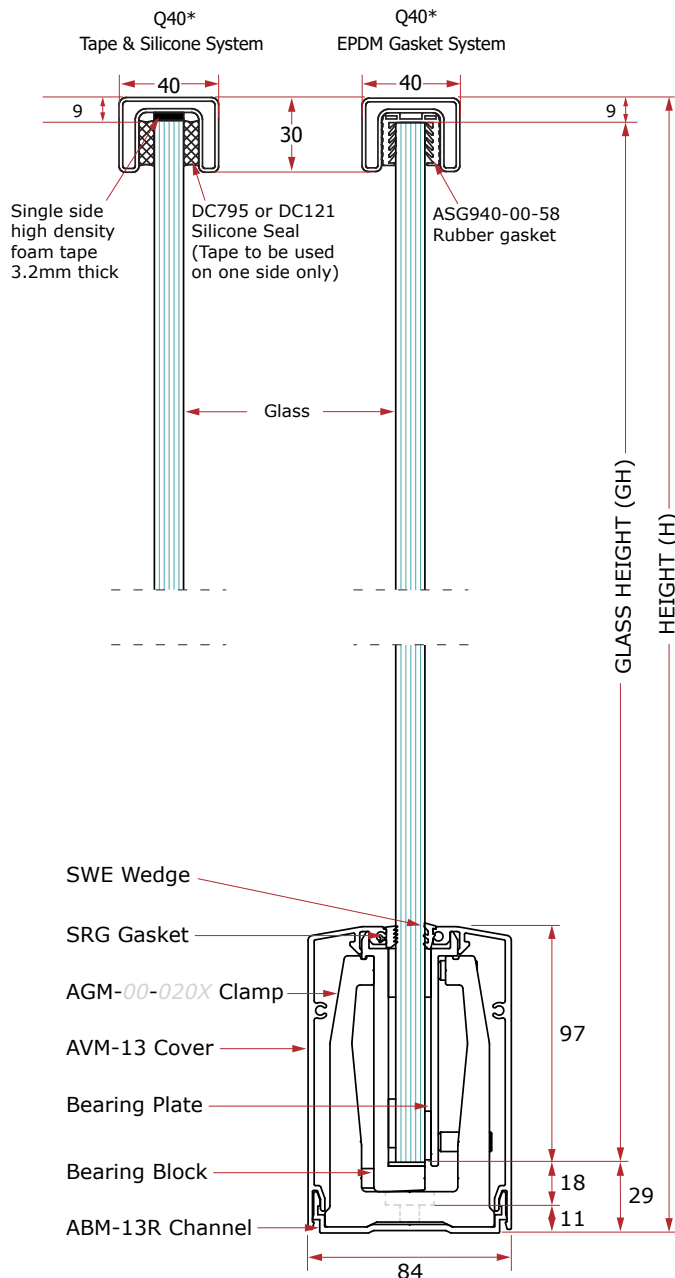

'METROPOLIS' (LRR SIDE RAIL) - VERTICAL DIMENSIONS

'METROPOLIS' (LRR SIDE RAIL) - VERTICAL DIMENSIONS ⁽¹⁾					
DIMENSION	FORMULA	TYPICAL VALUES (mm)			
HEIGHT ⁽²⁾	(H)	As specified	1000	1100	1200
GLASS HEIGHT	(GH)	H-29 ⁽⁴⁾	971	1071	1171

1. This table applies only with the use of the parts specified below.
2. The typical heights used assume that the Glazing Channel is affixed to the top of the deck surface.
3. Minor dimensions on the drawings have been rounded to the nearest millimetre.
4. These Vertical Dimensions are based on the top of the glass being 100mm above the top of the side rail which **MUST** be at the Minimum Barrier Height in accordance with NZBC F4/AS1.

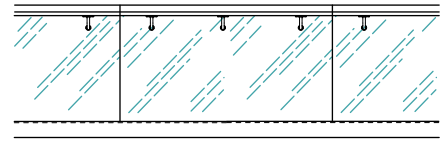

This is a guide for recommended cutting dimensions using the typical extrusions and components illustrated; use of others may require adjustments to the formulae and dimensions given here.

REFER TO THE Assembly Specification FOR FURTHER DETAILS

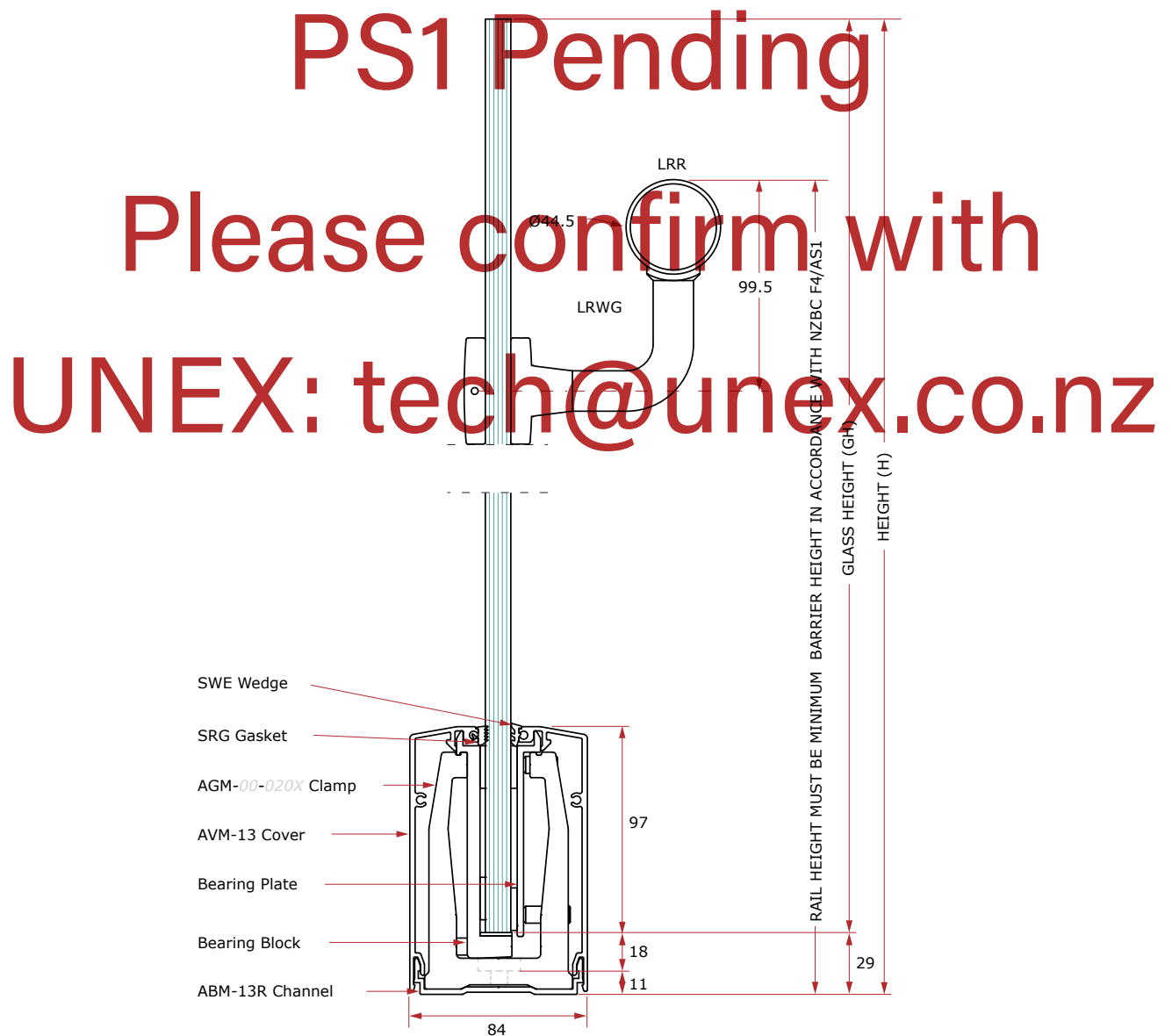

FABRICATION & INSTALLATION

NZBAL-D13.1 | SPEC ID **VD.61.00**

'PANORAMA' (NO RAIL) - VERTICAL DIMENSIONS

'PANORAMA' (NO RAIL) - VERTICAL DIMENSIONS ⁽¹⁾					
DIMENSION	FORMULA	TYPICAL VALUES (mm)			
HEIGHT ⁽²⁾	(H)	As specified	1000	1100	1200
GLASS HEIGHT	(GH)	H+98	1098	1198	1298

1. This table applies only with the use of the parts specified below.
 2. The typical heights used assume that the Glazing Channel is affixed to the deck front surface.
 3. Minor dimensions on the drawings have been rounded to the nearest millimetre.

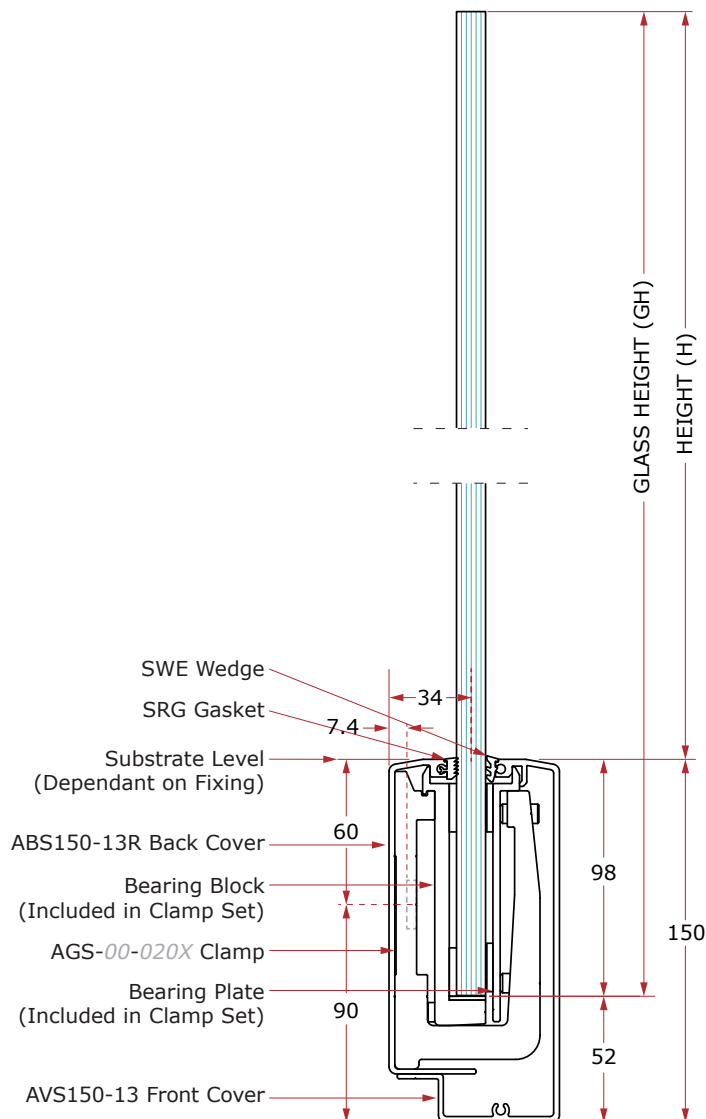
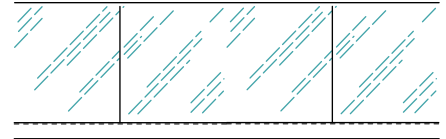

Specifications subject to change without notice

'PANORAMA' (VRR TOP RAIL) - VERTICAL DIMENSIONS

'PANORAMA' (VRR TOP RAIL) - VERTICAL DIMENSIONS ⁽¹⁾					
DIMENSION	FORMULA	TYPICAL VALUES (mm)			
HEIGHT ⁽²⁾	(H)	As specified	1000	1100	1200
GLASS HEIGHT	(GH)	H+98-16	1082	1182	1282

1. This table applies only with the use of the parts specified below.
2. The typical heights used assume that the Glazing Channel is affixed to the deck front surface.
3. Minor dimensions on the drawings have been rounded to the nearest millimetre.

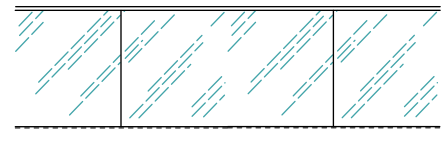

This is a guide for recommended cutting dimensions using the typical extrusions and components illustrated; use of others may require adjustments to the formulae and dimensions given here.

REFER TO THE Assembly Specification FOR FURTHER DETAILS

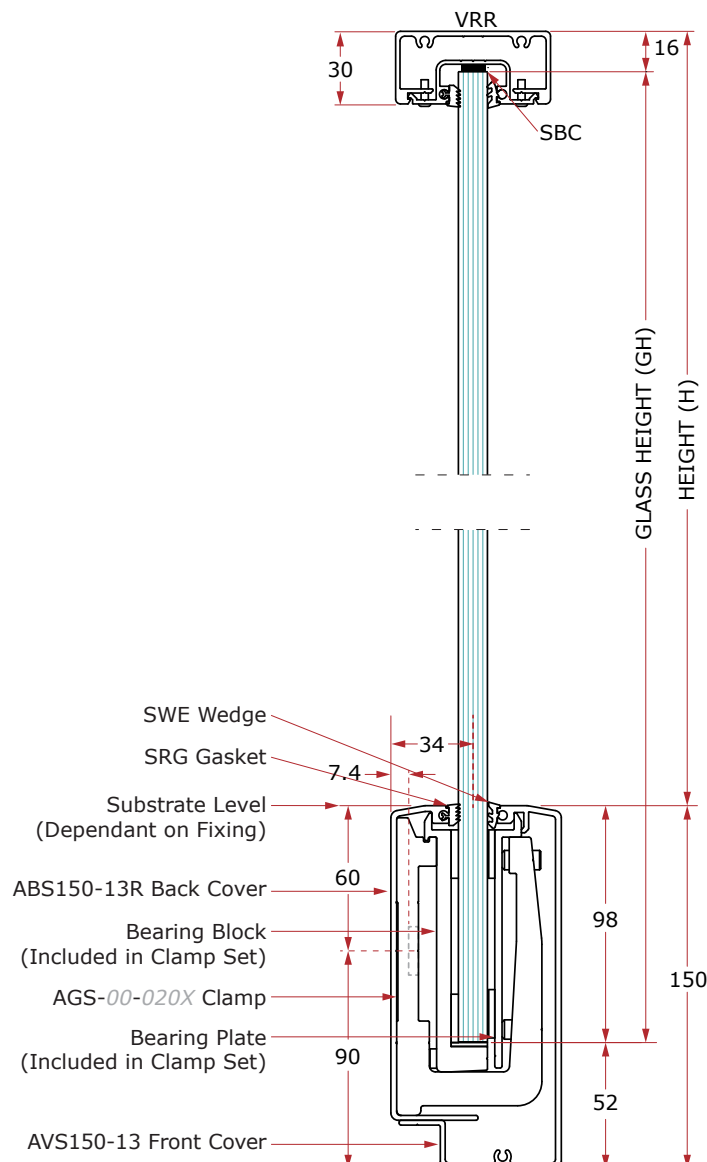

'PANORAMA' (Q25 STAINLESS STEEL TOP RAIL) - VERTICAL DIMENSIONS

DIMENSION	FORMULA	TYPICAL VALUES (mm)		
HEIGHT ⁽²⁾ (H)	As specified	1000	1100	1200
GLASS HEIGHT (GH)	H+98-9 ⁽⁴⁾	1089	1189	1289

1. This table applies only with the use of the parts specified below.
2. The typical heights used assume that the Glazing Channel is affixed to the deck front surface.
3. Minor dimensions on the drawings have been rounded to the nearest millimetre.
4. These Vertical Dimensions are based on the top of the glass being 100mm above the top of the side rail which MUST be at the Minimum Barrier Height in accordance with NZBC F4/AS1.

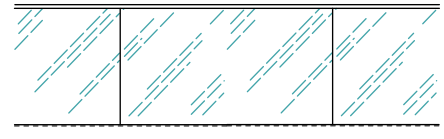

This is a guide for recommended cutting dimensions using the typical extrusions and components illustrated; use of others may require adjustments to the formulae and dimensions given here.

REFER TO THE Assembly Specification FOR FURTHER DETAILS

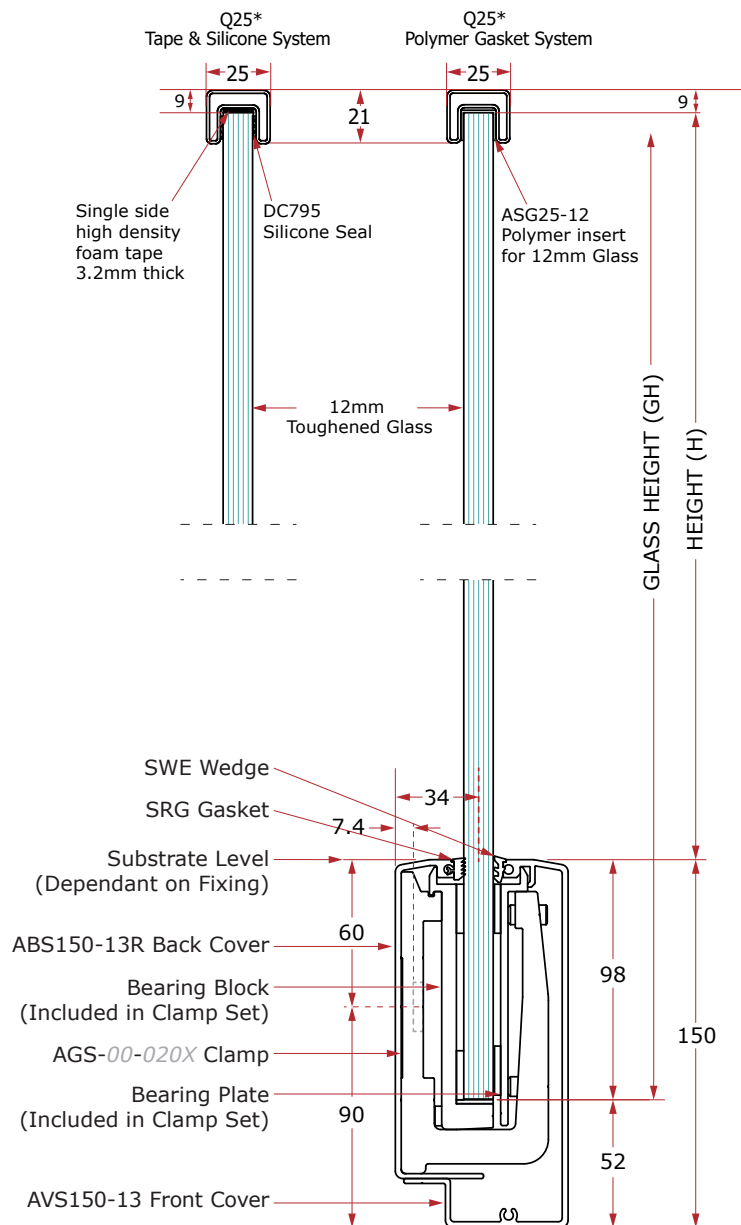

'PANORAMA' (Q40 STAINLESS STEEL TOP RAIL) - VERTICAL DIMENSIONS

DIMENSION	FORMULA	TYPICAL VALUES (mm)			
HEIGHT ⁽²⁾	(H)	As specified	1000	1100	1200
GLASS HEIGHT	(GH)	$H+98-9^{(4)}$	1089	1189	1289

1. This table applies only with the use of the parts specified below.
2. The typical heights used assume that the Glazing Channel is affixed to the deck front surface.
3. Minor dimensions on the drawings have been rounded to the nearest millimetre.

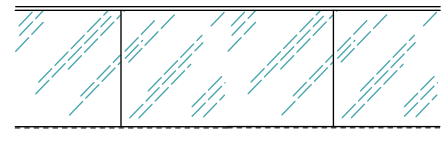

This is a guide for recommended cutting dimensions using the typical extrusions and components illustrated; use of others may require adjustments to the formulae and dimensions given here.

REFER TO THE Assembly Specification FOR FURTHER DETAILS

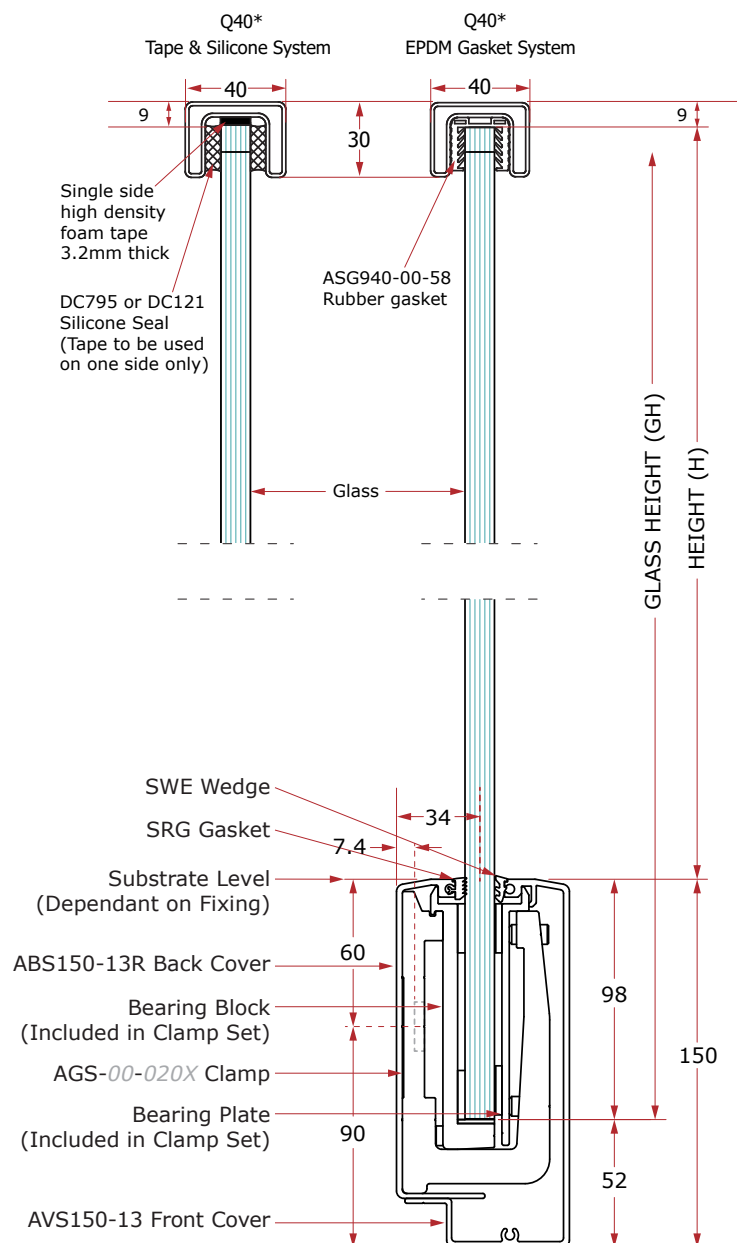

'PANORAMA' (LRR SIDE RAIL) - VERTICAL DIMENSIONS

DIMENSION	FORMULA	TYPICAL VALUES (mm)		
HEIGHT ⁽²⁾ (H)	As specified	1000	1100	1200
GLASS HEIGHT (GH)	H+98 ⁽⁴⁾	1098	1198	1298

1. This table applies only with the use of the parts specified below.
2. The typical heights used assume that the Glazing Channel is affixed to the deck front surface.
3. Minor dimensions on the drawings have been rounded to the nearest millimetre.
4. These Vertical Dimensions are based on the top of the glass being 100mm above the top of the side rail which MUST be at the Minimum Barrier Height in accordance with NZBC F4/AS1.

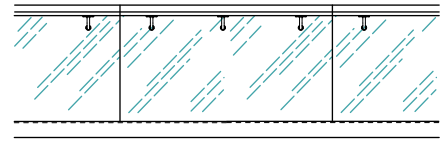

This is a guide for recommended cutting dimensions using the typical extrusions and components illustrated; use of others may require adjustments to the formulae and dimensions given here.

REFER TO THE Assembly Specification FOR FURTHER DETAILS

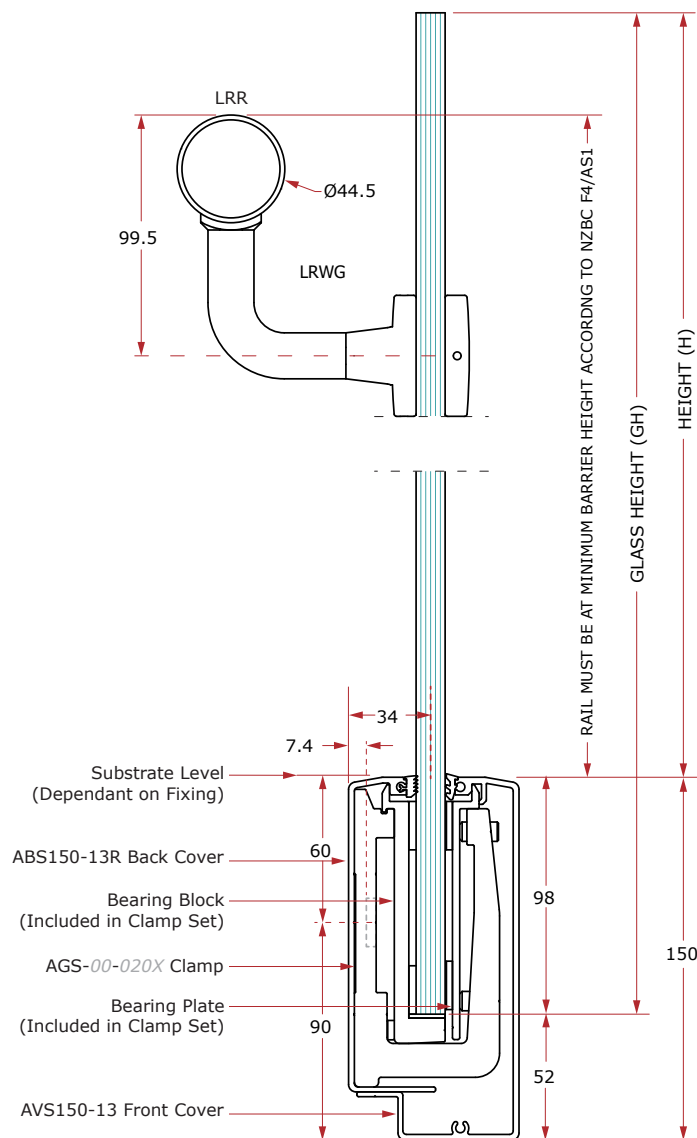

'PANORAMA' (STAINLESS STEEL SIDE RAIL*) - VERTICAL DIMENSIONS

*44.5mm Ø x 1.5mm Wall Thickness Stainless Steel Circular Tube (Grade 316)

'PANORAMA' (STAINLESS STEEL SIDE RAIL) - VERTICAL DIMENSIONS ⁽¹⁾					
DIMENSION	FORMULA	TYPICAL VALUES (mm)			
HEIGHT ⁽²⁾	(H)	As specified	1000	1100	1200
GLASS HEIGHT	(GH)	H+98 ⁽⁴⁾	1098	1198	1298

1. This table applies only with the use of the parts specified below.
2. The typical heights used assume that the Glazing Channel is affixed to the deck front surface.
3. Minor dimensions on the drawings have been rounded to the nearest millimetre.
4. These Vertical Dimensions are based on the top of the glass being 100mm above the top of the side rail which MUST be at the Minimum Barrier Height in accordance with NZBC F4/AS1.

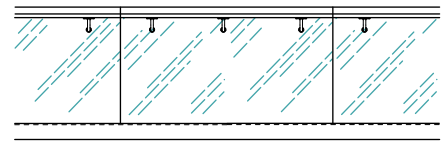

This is a guide for recommended cutting dimensions using the typical extrusions and components illustrated; use of others may require adjustments to the formulae and dimensions given here.

REFER TO THE Assembly Specification FOR FURTHER DETAILS

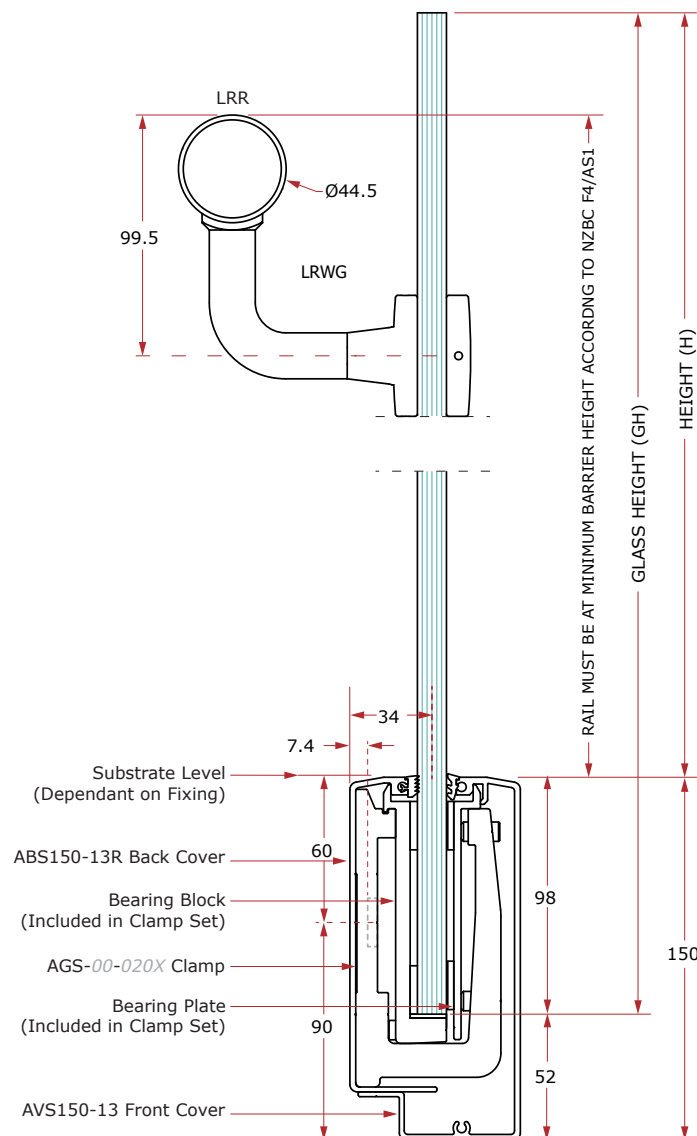

'ARENA-POINTS' (NO TOP RAIL)

'ARENA-POINTS' (NO TOP RAIL) - VERTICAL DIMENSIONS ⁽¹⁾				
DIMENSION	FORMULA	TYPICAL VALUES (mm)		
HEIGHT ⁽²⁾ (H)	As specified	1000	1100	1200
GLASS HEIGHT (GH)	$H+FS+VFS+45$	1184 MIN	1284 MIN	1384 MIN

1. This table applies only with the use of the parts specified below.
 2. The typical heights used assume that the Glazing Channel is affixed to the deck front surface.
 3. Minor dimensions on the drawings have been rounded to the nearest millimetre.

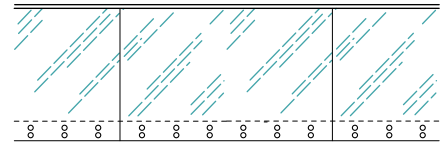

This is a guide for recommended cutting dimensions using the typical extrusions and components illustrated; use of others may require adjustments to the formulae and dimensions given here.

REFER TO THE Assembly Specification FOR FURTHER DETAILS

PS1 Pending

Please confirm with

UNEX: tech@unex.co.nz

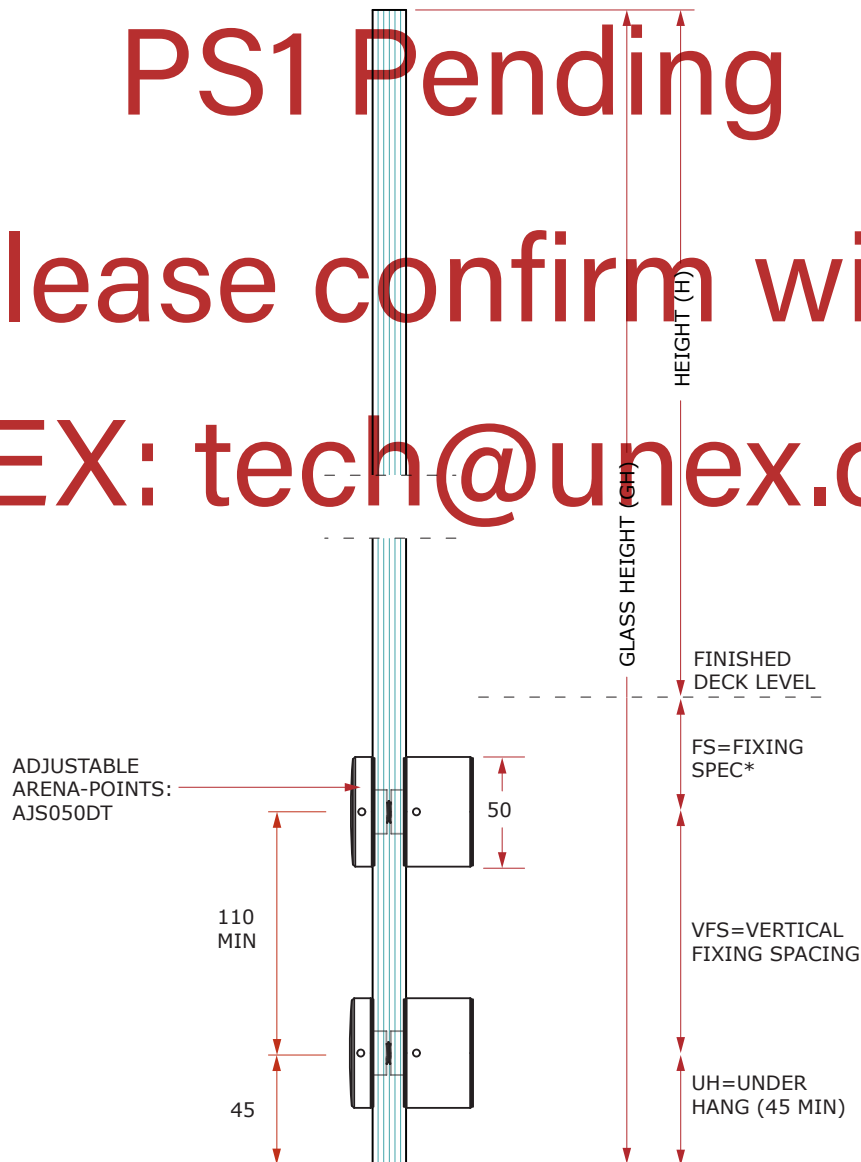

*Refer to fixing specifications

'ARENA-POINTS' (VRR TOP RAIL) - VERTICAL DIMENSIONS

'ARENA-POINTS' (VRR TOP RAIL) - VERTICAL DIMENSIONS ⁽¹⁾				
DIMENSION	FORMULA	TYPICAL VALUES (mm)		
HEIGHT ⁽²⁾ (H)	As specified	1000	1100	1200
GLASS HEIGHT (GH)	$H+FS+VFS+45$	1184 MIN	1284 MIN	1384 MIN

1. This table applies only with the use of the parts specified below.
 2. The typical heights used assume that the Glazing Channel is affixed to the deck front surface.
 3. Minor dimensions on the drawings have been rounded to the nearest millimetre.

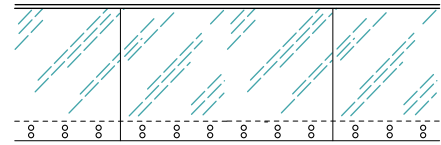

This is a guide for recommended cutting dimensions using the typical extrusions and components illustrated; use of others may require adjustments to the formulae and dimensions given here.

REFER TO THE Assembly Specification FOR FURTHER DETAILS

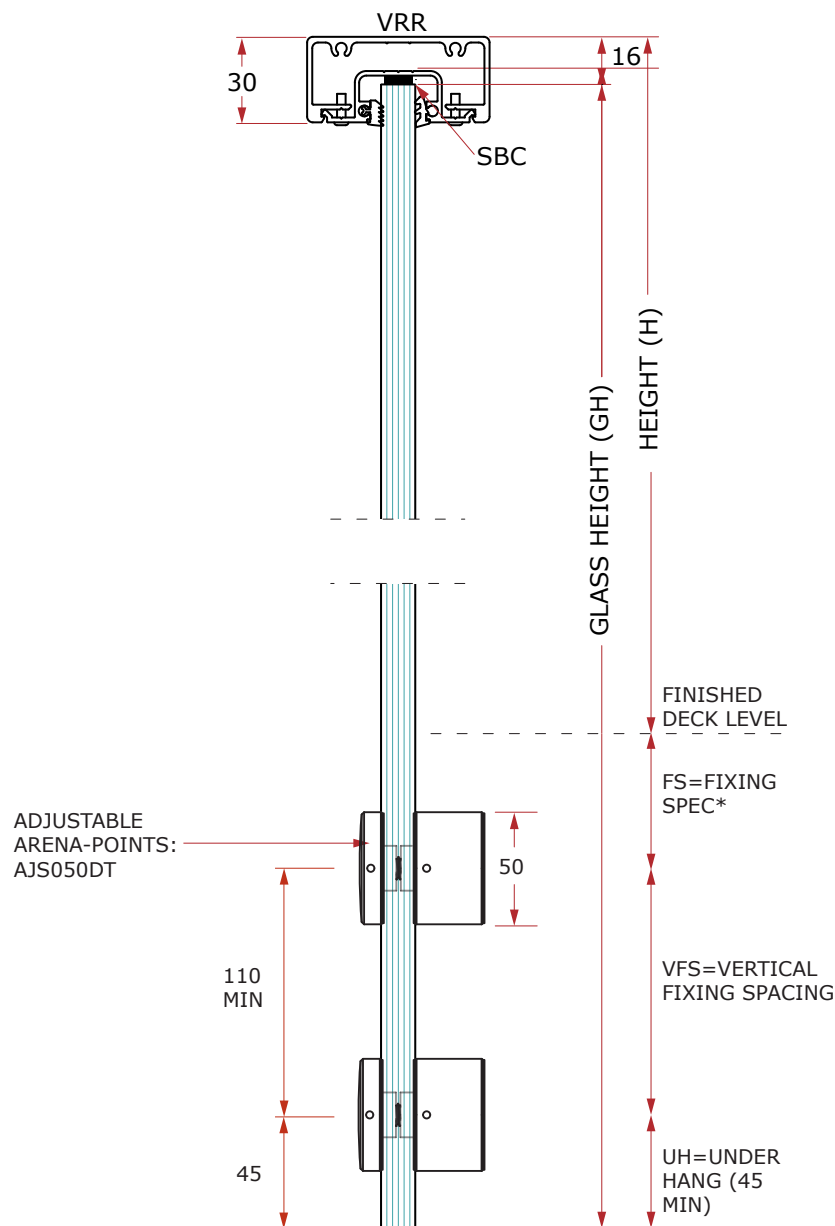

*Refer to fixing specifications

ARENA-POINTS' (Q25 STAINLESS STEEL TOP RAIL) - VERTICAL DIMENSIONS

'ARENA-POINTS' (Q25 TOP RAIL) - VERTICAL DIMENSIONS ⁽¹⁾				
DIMENSION	FORMULA	TYPICAL VALUES (mm)		
HEIGHT ⁽²⁾ (H)	As specified	1000	1100	1200
GLASS HEIGHT (GH)	H+FS+VFS+45-9	1191 MIN	1291 MIN	1391 MIN

1. This table applies only with the use of the parts specified below.
 2. The typical heights used assume that the Glazing Channel is affixed to the deck front surface.
 3. Minor dimensions on the drawings have been rounded to the nearest millimetre.

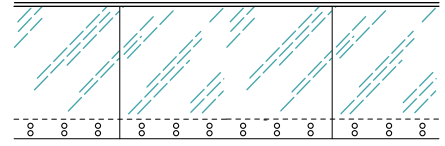

This is a guide for recommended cutting dimensions using the typical extrusions and components illustrated; use of others may require adjustments to the formulae and dimensions given here.

REFER TO THE Assembly Specification FOR FURTHER DETAILS

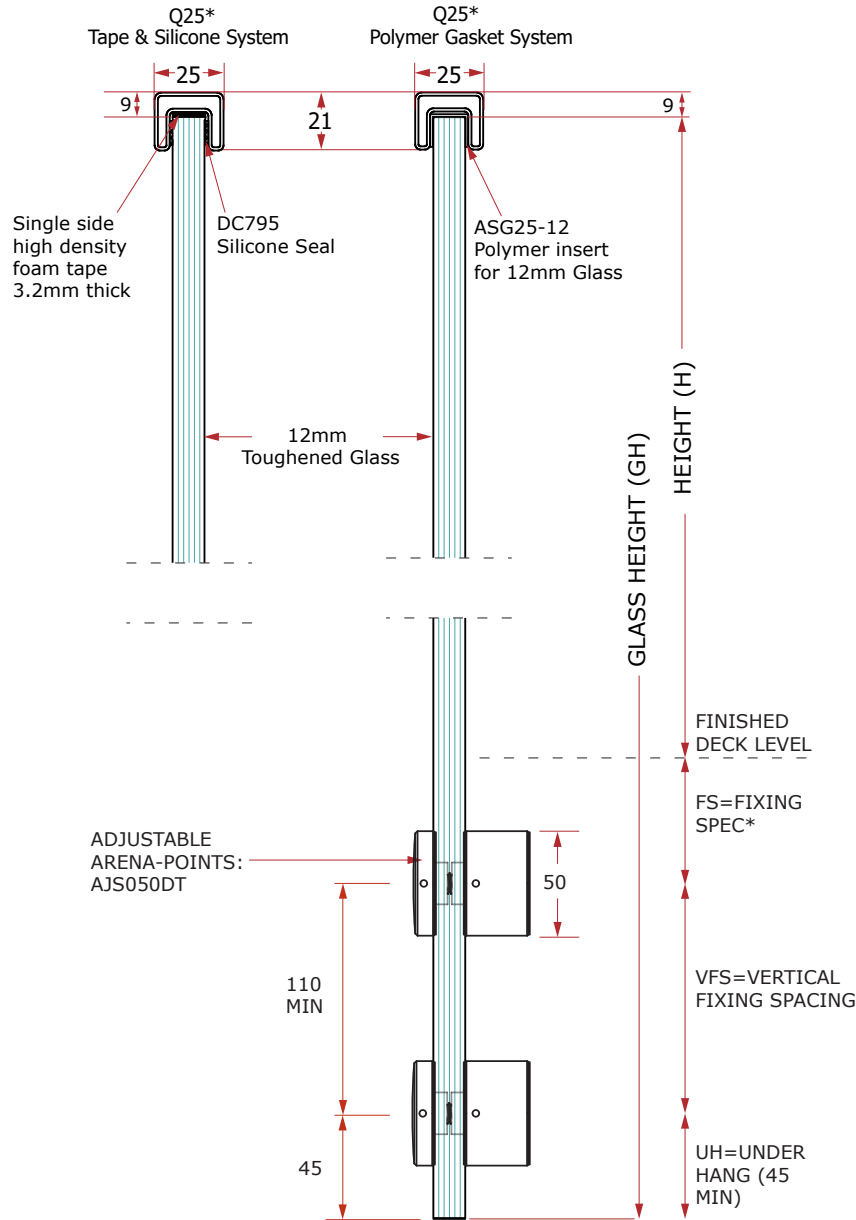

*Refer to fixing specifications

Specifications subject to change without notice

ARENA-POINTS' (Q40 STAINLESS STEEL TOP RAIL) - VERTICAL DIMENSIONS

'ARENA-POINTS' (Q40 TOP RAIL) - VERTICAL DIMENSIONS ⁽¹⁾				
DIMENSION	FORMULA	TYPICAL VALUES (mm)		
HEIGHT ⁽²⁾ (H)	As specified	1000	1100	1200
GLASS HEIGHT (GH)	$H + FS + VFS + 45 - 9$	1191 MIN	1291 MIN	1391 MIN

1. This table applies only with the use of the parts specified below.
2. The typical heights used assume that the Glazing Channel is affixed to the deck front surface.
3. Minor dimensions on the drawings have been rounded to the nearest millimetre.

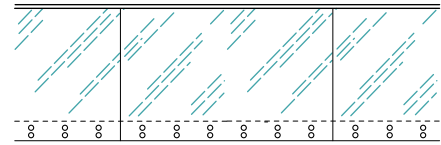

This is a guide for recommended cutting dimensions using the typical extrusions and components illustrated; use of others may require adjustments to the formulae and dimensions given here.

REFER TO THE Assembly Specification FOR FURTHER DETAILS

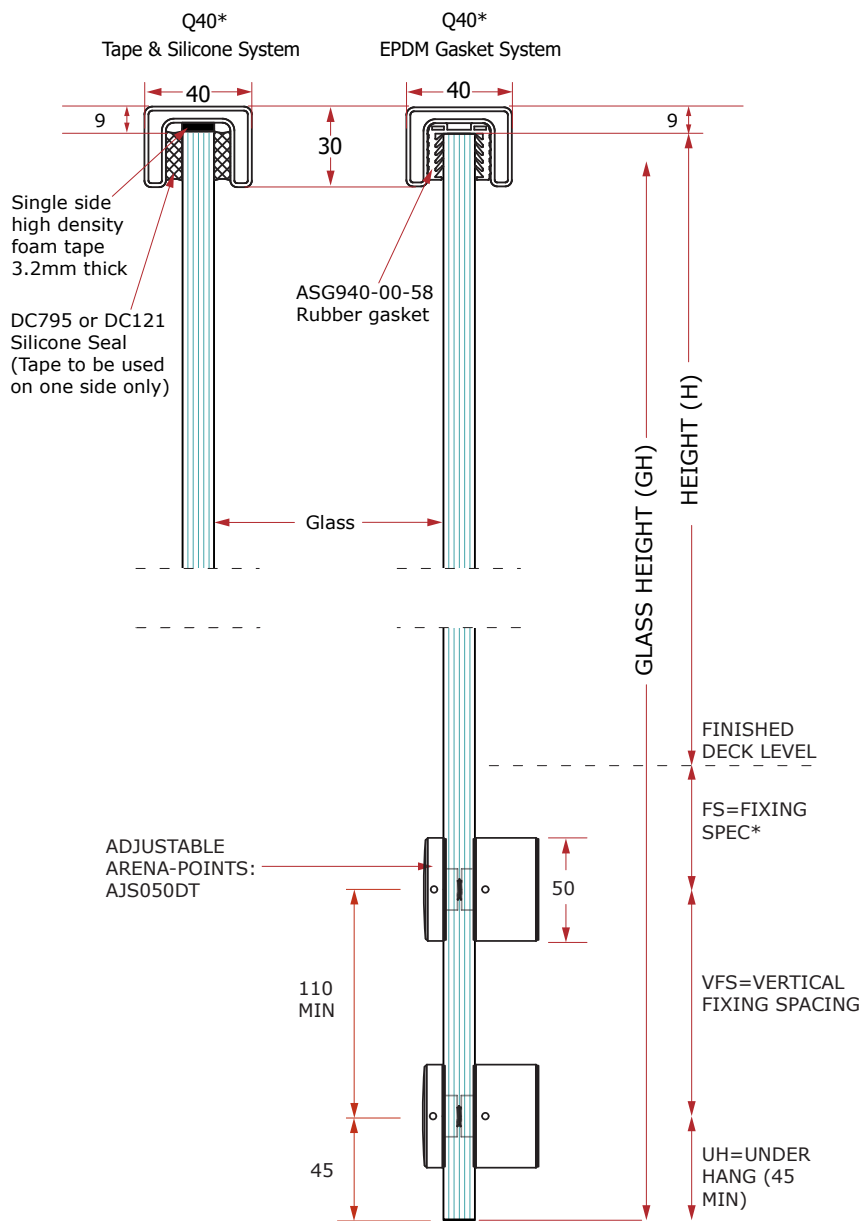

*Refer to fixing specifications

'ARENA-POINTS' (VRR SIDE RAIL) - VERTICAL DIMENSIONS

DIMENSION	FORMULA	TYPICAL VALUES (mm)		
HEIGHT ⁽²⁾ (H)	As specified	1000	1100	1200
GLASS HEIGHT (GH)	H+FS+VFS	1200 MIN	1300 MIN	1400 MIN

- This table applies only with the use of the parts specified below.
- The typical heights used assume that the Glazing Channel is affixed to the deck front surface.
- Minor dimensions on the drawings have been rounded to the nearest millimetre.
- These Vertical Dimensions are based on the top of the glass being 100mm above the top of the side rail which MUST be at the Minimum Barrier Height in accordance with NZBC F4/AS1.

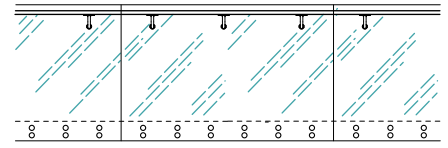

This is a guide for recommended cutting dimensions using the typical extrusions and components illustrated; use of others may require adjustments to the formulae and dimensions given here.

REFER TO THE Assembly Specification FOR FURTHER DETAILS

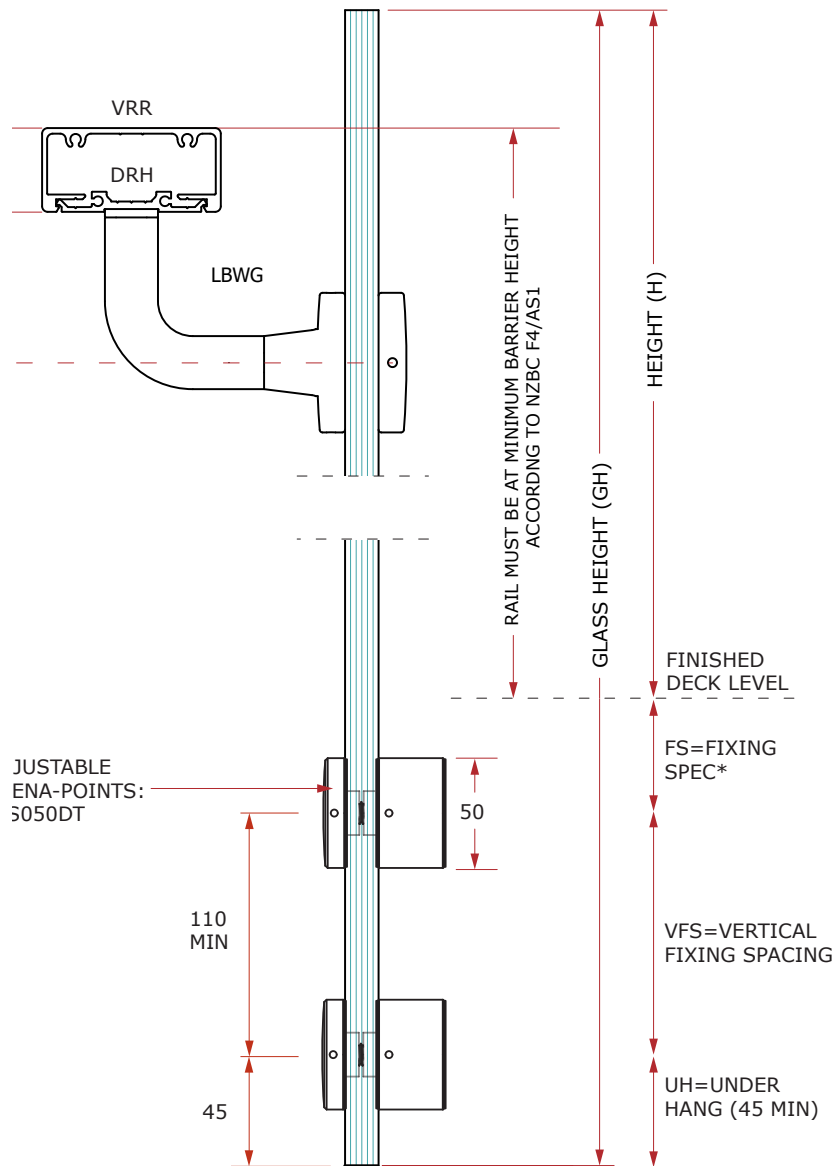

*Refer to fixing specifications

ARENA-POINTS' (LRR SIDE RAIL) - VERTICAL DIMENSIONS

'ARENA-POINTS' (LRR SIDE RAIL) - VERTICAL DIMENSIONS ⁽¹⁾					
DIMENSION		FORMULA	TYPICAL VALUES (mm)		
HEIGHT ⁽²⁾	(H)	As specified	1000	1100	1200
GLASS HEIGHT	(GH)	H+FS+VFS	1200 MIN	1300 MIN	1400 MIN

1. This table applies only with the use of the parts specified below.
2. The typical heights used assume that the Glazing Channel is affixed to the deck front surface.
3. Minor dimensions on the drawings have been rounded to the nearest millimetre.
4. These Vertical Dimensions are based on the top of the glass being 100mm above the top of the side rail which MUST be at the Minimum Barrier Height in accordance with NZBC F4/AS1.

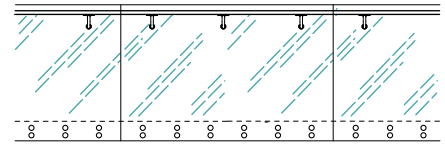

This is a guide for recommended cutting dimensions using the typical extrusions and components illustrated; use of others may require adjustments to the formulae and dimensions given here.

REFER TO THE Assembly Specification FOR FURTHER DETAILS

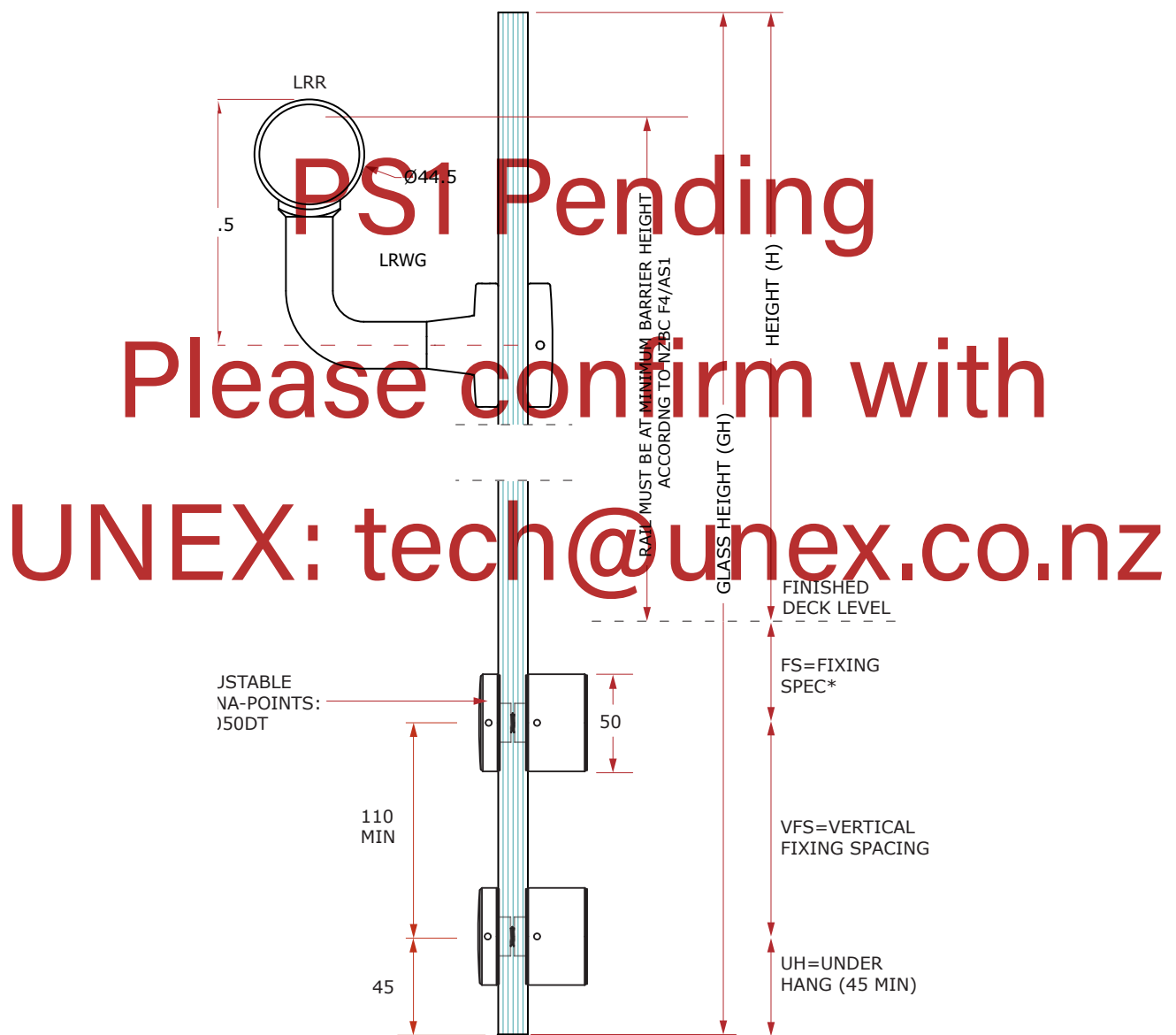

*Refer to fixing specifications

'GLASSTRUT' - TOP FIXED' (NO RAIL) - VERTICAL DIMENSIONS

'GLASSTRUT' TOP FIXED (NO TOP RAIL) - VERTICAL DIMENSIONS ⁽¹⁾					
DIMENSION	FORMULA	TYPICAL VALUES (mm)			
HEIGHT ⁽²⁾	(H)	As specified	1000	1100	1200
GLASS HEIGHT	(GH)	H-US	940	1040	1140

1. This table applies only with the use of the parts specified below.
 2. The typical heights used assume that the Glazing Channel is affixed to the deck front surface.
 3. Minor dimensions on the drawings have been rounded to the nearest millimetre.

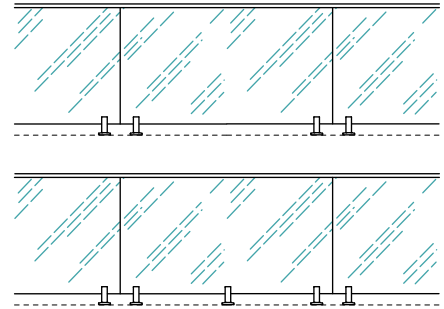

This is a guide for recommended cutting dimensions using the typical extrusions and components illustrated; use of others may require adjustments to the formulae and dimensions given here.

REFER TO THE Assembly Specification FOR FURTHER DETAILS

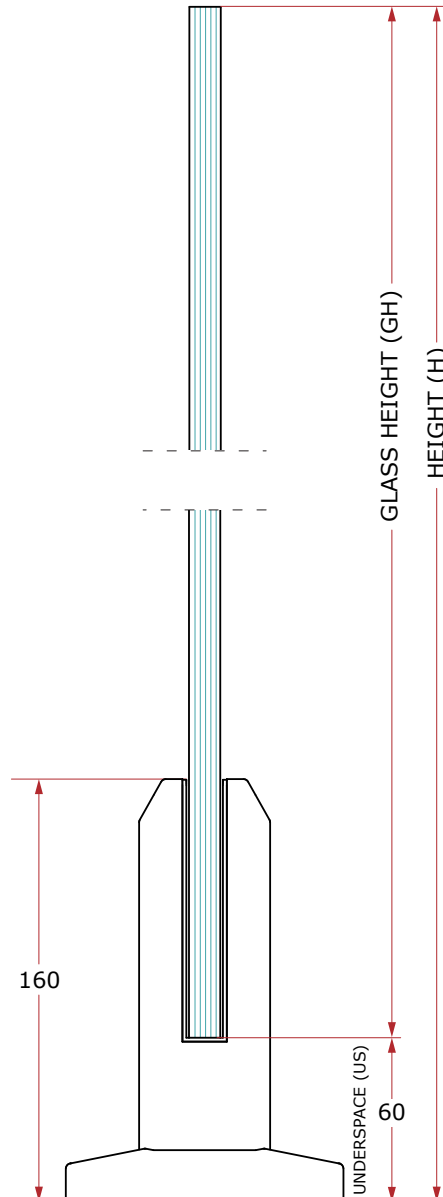

'GLASSTRUT' - TOP FIXED' (VRR TOP RAIL) - VERTICAL DIMENSIONS

'GLASSTRUT' TOP FIXED (VRR TOP RAIL) - VERTICAL DIMENSIONS ⁽¹⁾					
DIMENSION	FORMULA	TYPICAL VALUES (mm)			
HEIGHT ⁽²⁾	(H)	As specified	1000	1100	1200
GLASS HEIGHT	(GH)	H-US-16	924	1024	1124

1. This table applies only with the use of the parts specified below.
2. The typical heights used assume that the Glazing Channel is affixed to the deck front surface.
3. Minor dimensions on the drawings have been rounded to the nearest millimetre.

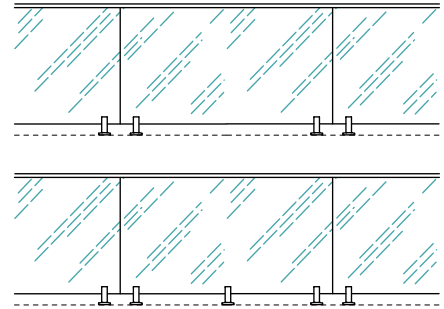

This is a guide for recommended cutting dimensions using the typical extrusions and components illustrated; use of others may require adjustments to the formulae and dimensions given here.

REFER TO THE Assembly Specification FOR FURTHER DETAILS

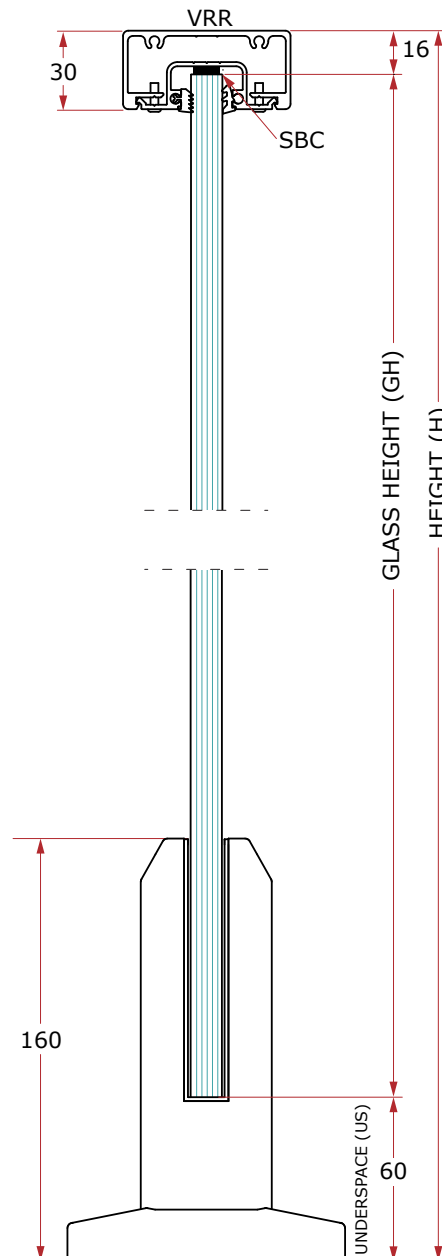

'GLASSTRUT - TOP FIXED' (Q25 STAINLESS STEEL TOP RAIL) - VERTICAL DIMENSIONS

DIMENSION	FORMULA	TYPICAL VALUES (mm)			
HEIGHT ⁽²⁾	(H)	As specified	1000	1100	1200
GLASS HEIGHT	(GH)	H-US-9	931	1031	1131

1. This table applies only with the use of the parts specified below.
2. The typical heights used assume that the Glazing Channel is affixed to the deck front surface.
3. Minor dimensions on the drawings have been rounded to the nearest millimetre.

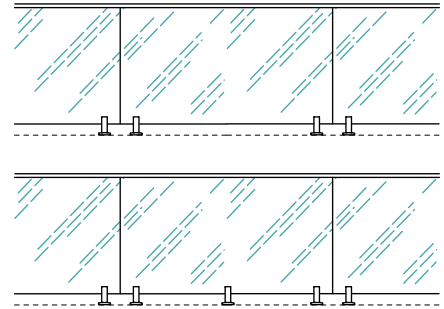

This is a guide for recommended cutting dimensions using the typical extrusions and components illustrated; use of others may require adjustments to the formulae and dimensions given here.

REFER TO THE Assembly Specification FOR FURTHER DETAILS

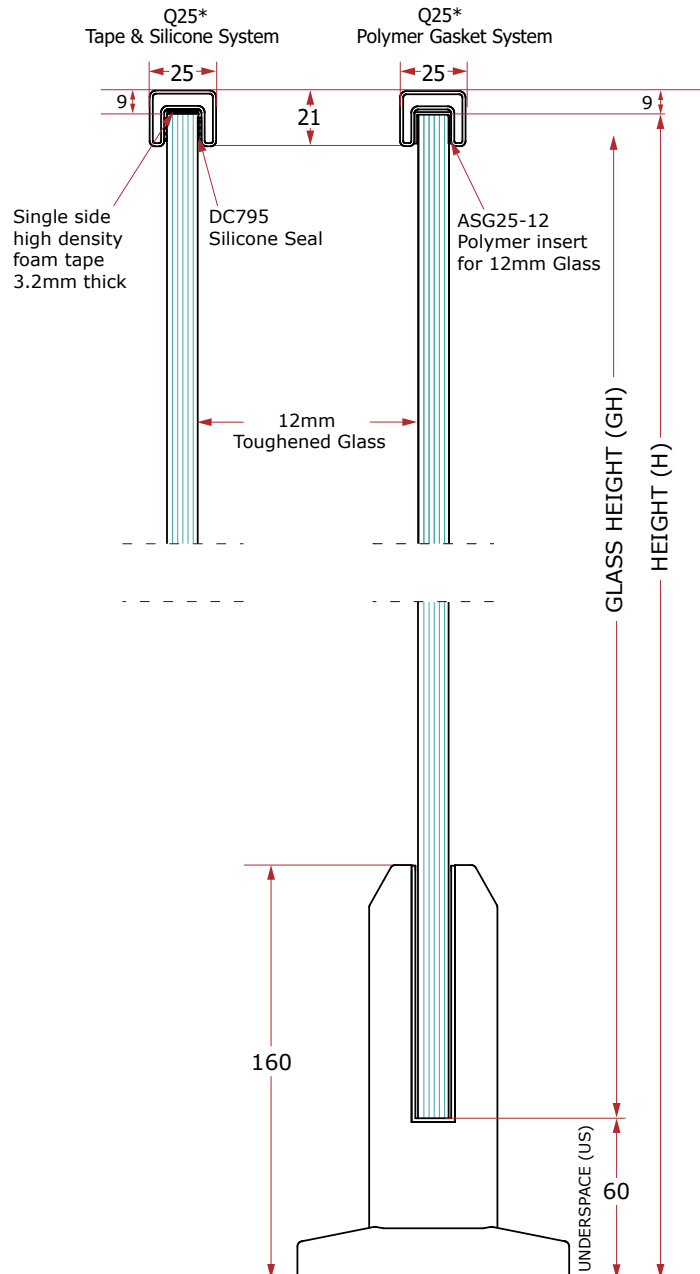

'GLASSTRUT' - TOP FIXED' (Q40 STAINLESS STEEL TOP RAIL) - VERTICAL DIMENSIONS

'GLASSTRUT' TOP FIXED (Q40 TOP RAIL) - VERTICAL DIMENSIONS ⁽¹⁾				
DIMENSION	FORMULA	TYPICAL VALUES (mm)		
HEIGHT ⁽²⁾ (H)	As specified	1000	1100	1200
GLASS HEIGHT (GH)	H-US-9	931	1031	1131

1. This table applies only with the use of the parts specified below.
2. The typical heights used assume that the Glazing Channel is affixed to the deck front surface.
3. Minor dimensions on the drawings have been rounded to the nearest millimetre.

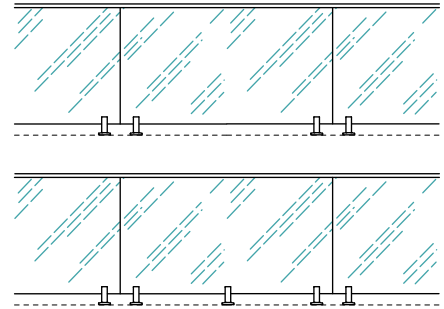

This is a guide for recommended cutting dimensions using the typical extrusions and components illustrated; use of others may require adjustments to the formulae and dimensions given here.

REFER TO THE Assembly Specification FOR FURTHER DETAILS

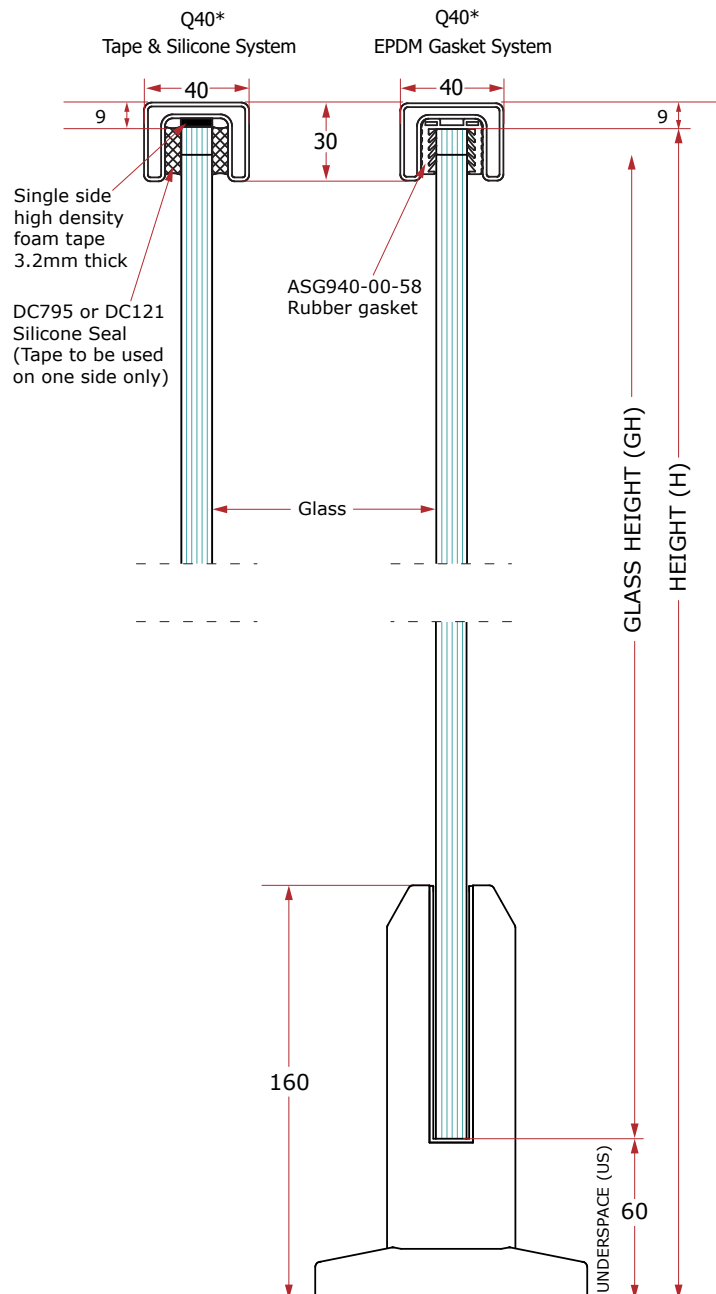

'GLASSTRUT - SIDE FIXED' (NO TOP RAIL) - VERTICAL DIMENSIONS

'GLASSTRUT' SIDE FIXED (NO TOP RAIL) - VERTICAL DIMENSIONS ⁽¹⁾					
DIMENSION	FORMULA	TYPICAL VALUES (mm)			
HEIGHT ⁽²⁾	(H)	As specified	1000	1100	1200
GLASS HEIGHT	(GH)	H-US	965	1065	1165

1. This table applies only with the use of the parts specified below.
 2. The typical heights used assume that the Glazing Channel is affixed to the deck front surface.
 3. Minor dimensions on the drawings have been rounded to the nearest millimetre.

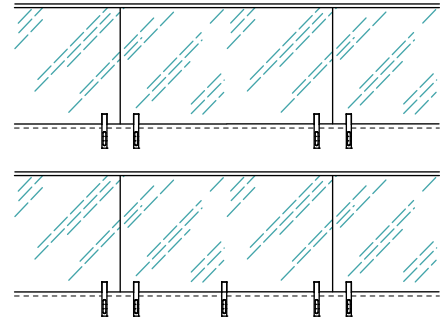

This is a guide for recommended cutting dimensions using the typical extrusions and components illustrated; use of others may require adjustments to the formulae and dimensions given here.

REFER TO THE Assembly Specification FOR FURTHER DETAILS

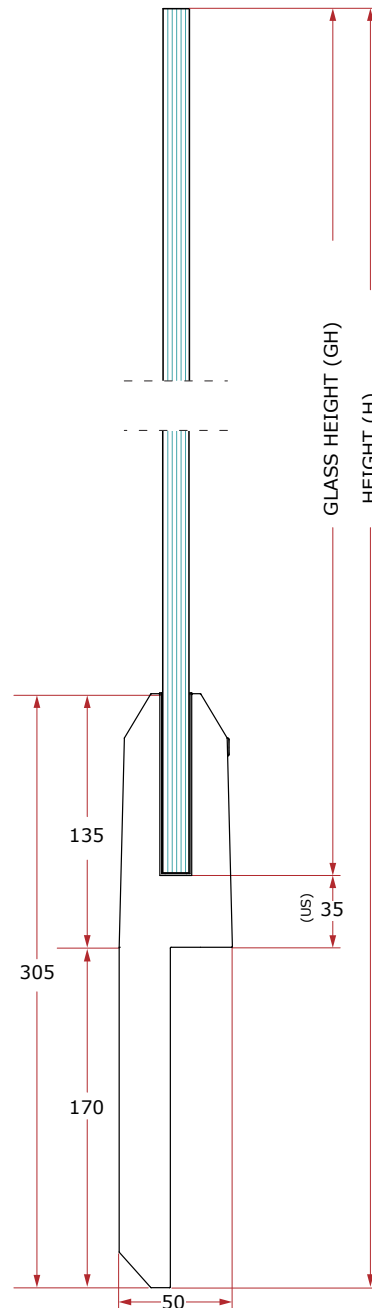

'GLASSTRUT' - SIDE FIXED' (VRR TOP RAIL) - VERTICAL DIMENSIONS

'GLASSTRUT' SIDE FIXED (VRR TOP RAIL) - VERTICAL DIMENSIONS ⁽¹⁾				
DIMENSION	FORMULA	TYPICAL VALUES (mm)		
HEIGHT ⁽²⁾ (H)	As specified	1000	1100	1200
GLASS HEIGHT (GH)	H-US-16	949	1049	1149

1. This table applies only with the use of the parts specified below.
2. The typical heights used assume that the Glazing Channel is affixed to the deck front surface.
3. Minor dimensions on the drawings have been rounded to the nearest millimetre.

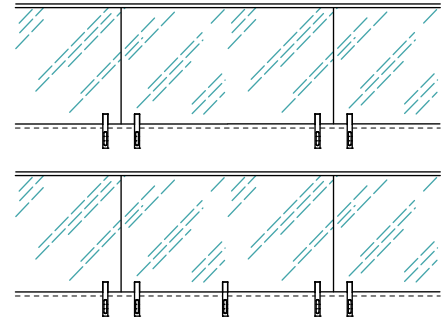

This is a guide for recommended cutting dimensions using the typical extrusions and components illustrated; use of others may require adjustments to the formulae and dimensions given here.

REFER TO THE Assembly Specification FOR FURTHER DETAILS

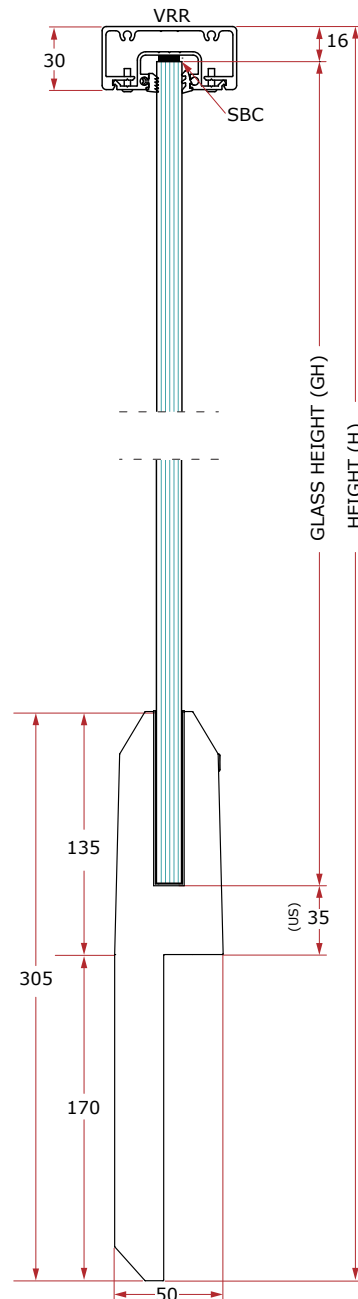

'GLASSTRUT - SIDE FIXED' (Q25 STAINLESS STEEL TOP RAIL) - VERTICAL DIMENSIONS

DIMENSION	FORMULA	TYPICAL VALUES (mm)			
HEIGHT ⁽²⁾	(H)	As specified	1000	1100	1200
GLASS HEIGHT	(GH)	H-US-9	956	1056	1156

1. This table applies only with the use of the parts specified below.
2. The typical heights used assume that the Glazing Channel is affixed to the deck front surface.
3. Minor dimensions on the drawings have been rounded to the nearest millimetre.

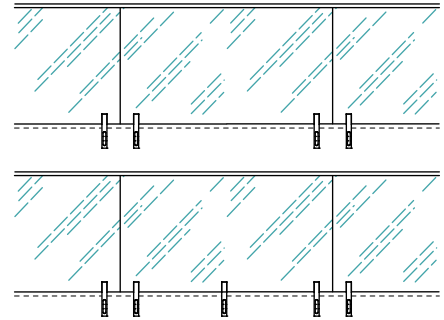

This is a guide for recommended cutting dimensions using the typical extrusions and components illustrated; use of others may require adjustments to the formulae and dimensions given here.

REFER TO THE Assembly Specification FOR FURTHER DETAILS

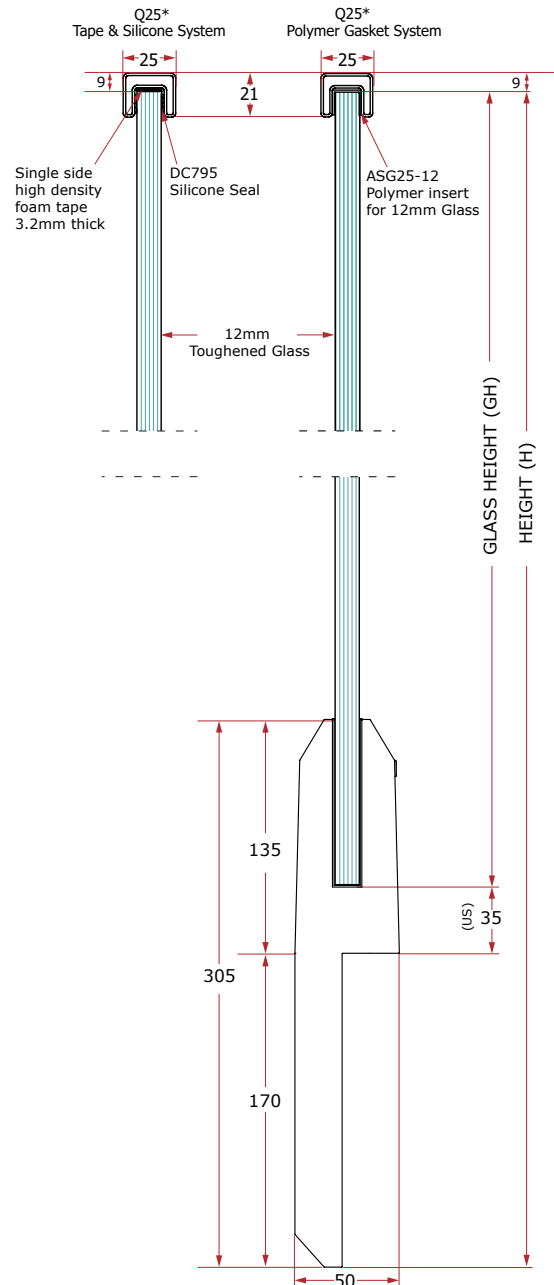

'GLASSTRUT' - SIDE FIXED' (Q40 STAINLESS STEEL TOP RAIL) - VERTICAL DIMENSIONS

'GLASSTRUT' SIDE FIXED (Q40 TOP RAIL) - VERTICAL DIMENSIONS ⁽¹⁾					
DIMENSION	FORMULA	TYPICAL VALUES (mm)			
HEIGHT ⁽²⁾	(H)	As specified	1000	1100	1200
GLASS HEIGHT	(GH)	H-US-9	956	1056	1156

1. This table applies only with the use of the parts specified below.
2. The typical heights used assume that the Glazing Channel is affixed to the deck front surface.
3. Minor dimensions on the drawings have been rounded to the nearest millimetre.

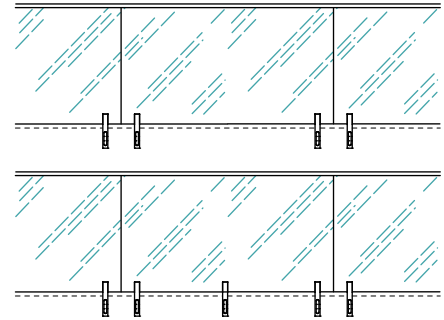

This is a guide for recommended cutting dimensions using the typical extrusions and components illustrated; use of others may require adjustments to the formulae and dimensions given here.

REFER TO THE Assembly Specification FOR FURTHER DETAILS

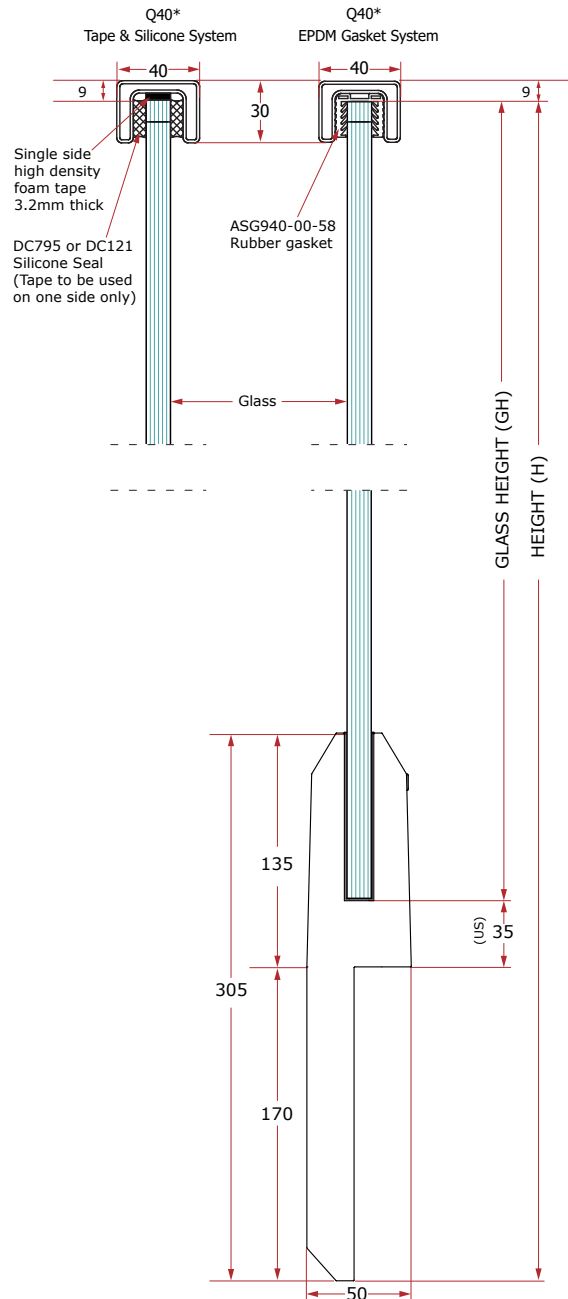

DURABILITY

The NZBC requires all balustrading to be sufficiently durable so as to remain functional for certain specified periods of time. These periods are given in the Acceptable Solution B2/AS1, which indicates a 'serviceable' durability requirement of 50 years for channels, points, and top rails, and 15 years for infill members.

Whilst specific details to achieve these requirements for the common situations are given throughout this manual, it is essential that they are applied to all exterior balustrade installations regardless. These issues may be placed under two general areas as follows;

1. DRAINAGE

Water entrapped in members can potentially be detrimental to the durability of a balustrade, and provision for moisture to drain must therefore be made. Common areas where such provision is necessary, and how it can be achieved is as follows;

1.1. TOP FIXED CHANNELS

Mill a Ø5mm slot 15mm long at 400mm centres or drill drainage Ø6mm holes along the sides at the base of the ABM-13 channel along the length of the extrusion at 400mm centres. The pre-drilled ABM-13R alignment channel has drainage holes provided.

1.2. SIDE FIXED CHANNELS

Drill a central Ø6mm drainage hole or cut a slot in the bottom of the AVS150-13 front cover as close as possible to the backside of the cover and substrate at every 600mm, to ensure all parts of the channel are drained.

1.3. INNER TOP RAILS

To minimise entrance of moisture, any Inner Top Rails (e.g. DRH, PZT etc) should be continuous wherever possible. Where joints are required, these shall have the smallest gap between rails.

2. SEPARATION OF MATERIALS

Dissimilar materials can react with each other in varying degrees if in contact with each other. This can potentially reduce the durability of a balustrade and measures must be taken to minimise this occurring. This means that aluminium members must be separated from other materials, including stainless steel fixings, as outlined below;

2.1. TOP FIXED CHANNELS

A separation washer shall be inserted between the channel and the underside of all stainless steel washers used for substrate fasteners. Note for FCP8-165 coach screws, the stainless steel and polymer washers will be adequate. Then for M12 studs or bolts an EPDM or neobonded washer (not polymer) shall be installed.

2.2. SIDE FIXED CHANNELS

- (a) A separation washer shall be placed between the stainless steel washer adjacent to the head of the fixing screw and the mounting holes of each AGS clamp.
- (b) When packers are used, a strip of neoprene gasket shall be placed between the back of the aluminium packers and the adjacent substrate at each fixing point. This may also assist with waterproofing issues if required. Product code SG120-12 neoprene gaskets available from UNEX, is 120mm wide by 1.2 metres long lengths which should be used with packers to separate it from the substrate.

Cut strips to the length equal to the size of the packers.

- (c) Where the stainless steel fixings pass through a clamp, the fixing shall be wrapped with approximately three turns of Teflon tape where it would otherwise be in contact with the aluminium clamp. UNEX product code is TTAM.

(continued on following Page)

DURABILITY (CONT.)

2.3. STAINLESS STEEL ASSEMBLY SCREWS

The following stainless steel assembly fasteners must be specially treated to minimise any reaction with the aluminium members. This process is carried out by UNEX, and these screws must therefore be purchased from them.

- All screws connecting posts to the post base-plates, or post blanks.
- All lower rail or mid rail spigot screws connecting the spigot to the post.
- All screws connecting the inner top rails or inner top glazing rails to the top of the posts.

2.4. GRADES OF STAINLESS STEEL

All stainless steel fixings and substrate fasteners must be grade 316 stainless steel for maximum durability.

2.5. OTHER

For situations not covered above; EPDM or Neoprene may be a useful product to provide separation between dissimilar materials, and Lanolin grease (available from UNEX – code TGL-05L) can be a useful product to place around areas of contact between aluminium and stainless steel fasteners.

EPOXY-SET ANCHOR STUDS - INSTALLATION SPECIFICATION

1. GENERAL

This is a specification for fixing Stainless Steel studs into structural concrete i.e.- FE10 and FE12 studs. The method used throughout this manual utilizes the Epcon C6 Plus system, and must not be substituted with other epoxies or chemset injection methods without an independent structural assessment of its adequacy to carry the design loads. Note that the Epcon C6 Plus system may be sold under other names in countries other than New Zealand.

2. MATERIALS

Studs shall be threaded 316 stainless steel studs having a minimum yield stress of 450MPa and a minimum tensile stress of 700 MPa (Grade 70). Typical designations are FE12-150 = an Ø12mm stainless steel threaded stud of 150mm overall length. Washers, nuts and dome nuts shall be stainless steel and separated from baseplate with either a neobonded or EPDM washer.

3. FIXING MATERIALS

- Cartridges: (TEC2) of Epoxy C6 Plus resin.
- Disposable Nozzles: (TEN2) Allow at least 2 nozzles per cartridge.
- Dispensing Handgun: (TEG2)
- Hole Brushes: (TEB)

4. EDGE DISTANCES

Studs must not be installed closer to the edge of the structural concrete, excluding any thickness of plaster or finishing, than shown on the Fixing Specifications in Chapter 3. Where no edge distance is stipulated use the following minimum distances:- FE10 = 40mm, FE12 = 50mm

5. PROCEDURE

- 5.1. For M10 studs, drill Ø12mm holes. For M12 studs, drill Ø14mm holes. Drill all holes with a carbide tipped drill. Check slab and topping thickness when choosing stud length. Drill holes approx 10mm deeper than stud depth.
- 5.2. Hole Cleaning: This procedure is very important for successful adhesion and must be carefully carried out.
 - (a) Blow dust and debris from hole using oil free compressed air with a tube "end fitting" or the TEW hand operated blower. In either case, insert tube to bottom of hole before blowing.
 - (b) Brush the hole sides thoroughly.
 - (c) Blow the hole clean a second time.
- 5.3. Place balustrade in its final position before injecting resin, ensuring the channel is vertical. Ensure studs are on-hand with nuts and washers pre-attached, as resin may set very quickly once dispensed. Studs should initially protrude 5-6mm for M10 studs, or 6-7mm for M12 studs, into nuts.
- 5.4. Remove cartridge cap, attach nozzle. (Retain the cap) Dispense resin to waste until it is evenly mixed to correct colour (see colour sample supplied with cartridge). Insert nozzle into hole and dispense resin. Due to possibility of air pockets, the only reliable indicator of sufficient resin in hole is to insert stud and watch for some surplus resin to be forced from the hole. Wipe surplus resin off immediately.
- 5.5. As each hole is resin injected, insert the stud with a slow twisting motion, before injecting the next hole. Do not pause more than 2 minutes during injection or a new nozzle may be required. Cap cartridge after use. Do not allow loads on balustrade, install glass, or tighten nuts, until fully cured. Refer to curing times on cartridge.
- 5.6. Do not install studs if temperature is less than 5°C. In all events carefully read and adhere to all instructions contained on the product packet etc.

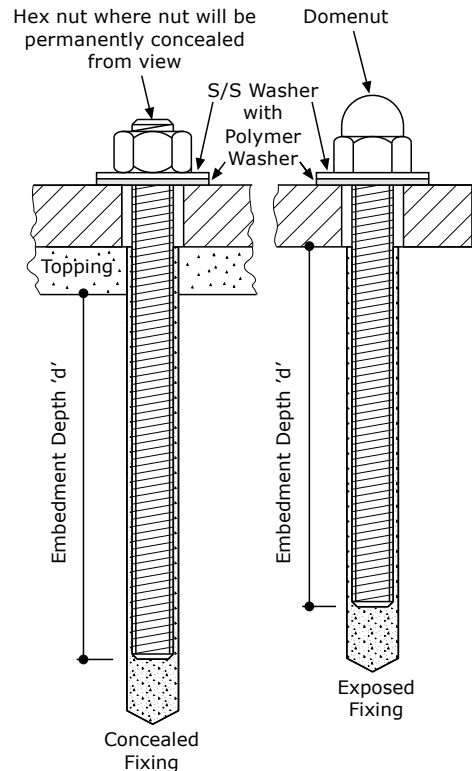

INSTALLATION GUIDE FOR METROPOLIS STYLE BALUSTRADES

APPLICATION

This Installation Guide covers the general fabrication of the 'Metropolis' AZM2® style Balustrade.

This Guide is intended only to cover details applicable to a common and straightforward deck configuration. For any other situation, or for details not covered below, contact UNEX.

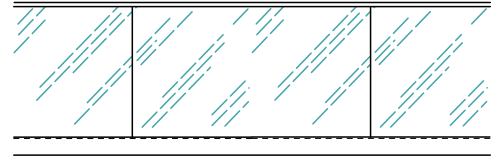

1. BALUSTRADE DESIGN

This section covers the measuring and design of the balustrade.

1.1 SITE MEASURE

Refer to "Site Measuring - General Guide" pages 129-130 for a guide of appropriate measurements that will need to be taken from the site.

1.2 BALUSTRADE SPECIFICATIONS

Ensure that adequate information and instructions have been received from customer to ensure the balustrade is designed to NZBC requirements. Such details could include; fixing methods, design wind speeds, building class designations, barrier heights, maximum opening widths, etc.

1.3 GLASS TYPE, GLASS THICKNESS, AND CLAMP ASSEMBLY CENTRES

From the relevant Style Specification, determine the appropriate glass type, thickness, and the maximum clamp assembly centres.

From the relevant Fixing Specification determine the fixing centres type and quantity of substrate fasteners. The fixing positions are determined by the Style Specification. Any variation in the balustrade height caused by deck falls must be considered for this step. Interpolate between values on the specification tables where necessary.

NB: Styles with top rails need to be securely attached to walls or a post at free ends.

1.4 OVERALL CENTRELINE DIMENSIONS

The Overall Centreline (OCL) is the measurement of all balustrade runs in a continuous line, measured along the glass centreline (CL) to each mitre, and to the end of each run (see Fig. 1).

From the site measurements, determine the OCL of the balustrade, the balustrade centre-line position and any length adjustments necessary due to corners in the deck (see Fig. 1). Also take into account any clearances needed where the balustrade meets a wall face, and top rail ends that require secure attachments to wall or posts.

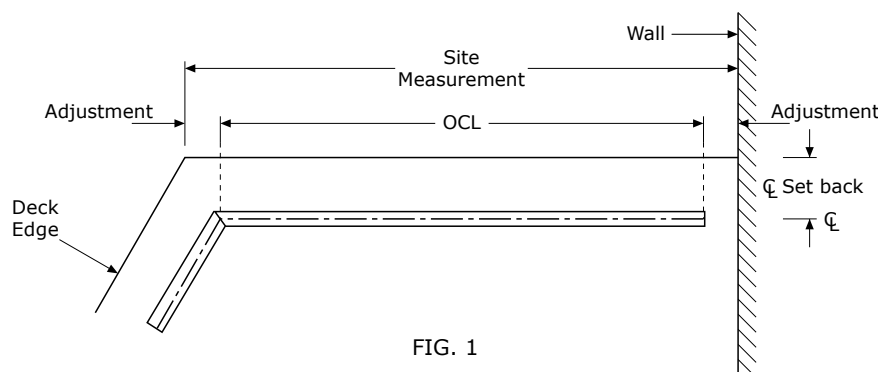

FIG. 1

1.5 VERTICAL DIMENSIONS

Calculate the balustrade heights and channel lengths to ensure the balustrade will meet all NZBC requirements, taking into account any deck falls and changes in deck levels.

The relevant Vertical Dimensions page will provide some useful formulae to calculate this data.

(continued on following Page)

INSTALLATION GUIDE FOR METROPOLIS STYLE BALUSTRADES - (CONT'D)

1.6 MATERIAL REQUIREMENTS

Optimise the various member types into available purchasing lengths, taking into account the additional lengths needed for mitre points, saw cuts and saw clamps etc. Any joins in the Top Outer Rail should not coincide with a join in the Top Inner Rail (if applicable).

Generate a summary of materials required and order from UNEX Systems.

The aluminum channel covers should be fully powdercoated or anodised.

2. FABRICATION

This section covers the cutting of the members to the required length, and the drilling of holes required. Ensure staff are provided with tools and machinery required, and have full instructions on how to use them. To prevent corrosion, ensure all tools/drivers/screwdriver tips are suitable for stainless steel and only used on stainless steel.

2.1 CUTTING TO LENGTH

Cut all members to their required length, as calculated in sections 1.4-1.6. Ensure all mitres are cut at the correct angle and orientation. Careful positioning of the cuts are required on the base alignment channel (ABM-13R) to coincide with the pre-drilled hole positions.

Remove all burrs of aluminium with a light file.

2.2 DRAINAGE HOLES

Ensure drainage holes are provided, which are pre-drilled on ABM-13R (Refer to Durability on page 193)

2.3 RETAINING GASKETS

Install the correct sized retaining gasket as per table on page 30, according to glass thickness, to the outer cover AVM-13 on the far side of the balustrade, prior to installation. The gasket are colour coded for identification.

3. INSTALLATION

This section covers the Installation of the balustrade extrusions and components. Prior to commencing, ensure the Builder has completed all work necessary to support the balustrade. For timber decks, satisfactory performance of the balustrade will only be obtained if the decking is adequately seasoned and stable.

3.1 PREPARATIONS

For all substrate types, ensure the deck where the balustrade is being mounted is straight and level. Installing the aluminium channels over tiles is not recommended as it may cause cracking of the tiles.

3.2 ABM-13R ALIGNMENT CHANNEL PLACEMENT

Position the base alignment channel ABM-13R on deck so that fixings will be in their correct position.

Attach the ABM-13R extrusion to the FFL of the deck at the correct location. Attachment at this stage can be done using either a temporary fastener, or by fixing of an AGM-00-020X clamp set in position. Take particular care to ensure precise alignment of the base alignment channel at all in-line joints.

3.3 AGM CLAMP POSITIONS

Position the AGM-00-020X clamps in accordance with the maximum centres determined in section 1.3. If this does not match the pre-drilled holes on the base alignment channel extrusion (ABM-13R) then mark and drill the base alignment channel at the desired position of each AGM-00-020X clamp set, according to the specified maximum centre. The clamping centre should be positioned 200mm off the end of glass panel, and intermediate sets spaced between without exceeding the specified centres. It is recommended that glass joints do not occur within a clamp, and is mandatory for SentryGlas infill panels.

3.4 FIXING HOLES

As per step 1.3, refer to the appropriate Fixing Specification for the fixing type & quantity of fasteners.

(continued on following Page)

INSTALLATION GUIDE FOR METROPOLIS STYLE BALUSTRADES - (CONT'D)

Fixings shall be within the provided counterbored holes of the AGM-00-020X clamps. Care should be taken to ensure that the heads of the substrate fixings do not interfere with the glass.

3.5 SUBSTRATE FASTENERS

It is essential that the channel is fastened in accordance with the Fixing Specification selected. All fixings should be Stainless Steel 316 Class 70 or greater.

For concrete decks, install fixing studs using Epcon C6 Plus epoxy anchoring systems as per Page 167 of the Fabricator's Manual and insert a EPDM or neobonded washer between the aluminium channel and the stainless-steel washer of the substrate fastener.

For timber decks, fixings within the channel must be either coach screws, or threaded studs right through the joists with stainless steel nyloc nuts and washers beneath. Fixings shall be central on the supporting joists which shall not be less than 45mm thick. Fit 50mm square washers under all bolt heads or nuts bearing on timber, unless otherwise specified by UNEX.

3.6 FINAL FIXING & AVM-13 OUTER COVER

Seal fastener holes, as necessary. Tighten all fasteners firmly, but not over-tightened.

Install the outside cover AVM-13 to far side of the clamp by lowering it down vertically, and clipping the lower end onto the ABM-13R base alignment channel, and the top to the bearing block/plate within the clamps.

3.7 PLUMB CHECK

Install a 'temporary panel' to the first and last clamps on each run and use a level to ensure the clamps are exactly plumbed. Run a string line between the top edges of the 'temporary panels' at each end.

Using a third 'temporary panel' work along the run through each of the clamps, plumbing each one to align the top edge of the third 'temporary panel' to the string line. Recheck for plumb, then remove the 'temporary panels'.

4. GLAZING

This section covers the measuring and installation of the glass panes. Ensure the correct thickness of toughened glass is used. All glass must be toughened in accordance with AS/NZ 2208. Visible edges shall be flat polished

4.1 GLASS SIZING AND ORDERING

Calculate and order the glass to the correct sizing, and consider position of safety stamp as default location may not be visible. For styles with no Top rail SentryGlas panes are the ONLY panes tested to support no top rail and are not to be shorter than 1.2m wide. Consideration should be given as to the size and weight of the panes and how they will be lifted into place on site.

4.2 GLASS JOINTS

Joints between adjacent glass panes may either have a 6mm gap and be silicone filled or have a clear gap between the panes of 10mm minimum to 95mm maximum (Note: A minimum of 12mm is preferred to prevent the risk of injury to children's fingers).

On corners, the glass may be either 'square cut and overlapped', or 'mitred' with a small 6mm gap and silicone filled.

It is essential with the 'Metropolis AZM2' style that joints are silicone filled on corners, so as to prevent the top edges of the glass coming in contact with each other when loads are placed upon them.

4.3 INSTALLING THE GLASS

Starting at one end, install the glass by placing it carefully into the AGM-00-020X clamps resting on the bearing block and against the bearing plate. Tighten the lower clamping grub screws only to hold the glass, then adjust the leveling screw so the glass is truly vertical above this clamp. Then tighten the top clamping grub screws taking care not to over tighten.

Recheck to see that the glass is vertical, aligned at all joints and that all clamping sets for each pane are perfectly in line. If further adjustment is required, loosen the top grub screws to adjust the leveling grub screw and retighten. Continue process along the balustrade, working along from one end.

(continued on following Page)

INSTALLATION GUIDE FOR METROPOLIS STYLE BALUSTRADES - (CONT'D)

5. FINISHING

This section covers the finishing touches of the aluminium balustrade.

5.1 INSTALLING THE INSIDE AVM-13 FRONT COVER

Install the inside AVM-13 covers by lowering it down vertically, and clipping the lower end onto the ABM-13R base alignment channel, and the top to the bearing block/plate within the clamps.

5.2 RAIL ATTACHMENT

Top rails protect monolithic glass against damage. Attach an SBC (SBG when using an ARN or VRT Top Rail) setting block to the top of the rail glazing cavity at 500 mm centres. Run an even bead of silicone continuously between them. One side of the rail should then be retained and the other side wedged, refer to Chapter 1 page 30 for gaskets and wedges. Special care shall be taken with wide top rails such as ART to obtain maximum firmness. Where the top rail comprises an inner and outer member, rivet the rails together with (FS4-4) rivets at 1000 mm centres.

Side rails are attached using LBWG (LRWG when using LRR rail) to provide a loading bearing, and continuous rail interlinking panes of glass. These brackets need to be inset 150mm from the glass pane edge on both ends for each pane and the top are required to be at the minimum barrier height according to NZBC F4/AS1.

For ARN Top Rails, jointers and gussets should use the MANG extrusion, refer to page 28 for standard jointers. Also, at jointers and gussets, glass must be protected with some thin adhesive tape over the top edge and down 10mm on each side. Use adhesive to secure in place. All other Top Rail mitres and joints should be securely held together using a DNS gusset or jointer.

5.3 INSTALLING THE WEDGE

Install the correct inside wedge between top of cover plate and glass as follows:

- 12mm glass SWE35 (Wedge installed deck side)
- 13.5mm glass SWE30 (Wedge installed deck side)
- 14.28mm glass SWE25 (Wedge installed deck side)
- 15mm glass SWE25 (Wedge installed deck side)

Cut the SWE^{XX} glazing wedge, leaving slightly over length. Ensure the fins of glazing gaskets are inserted towards the face of the glass. Compress gaskets lengthwise during insertion. Use a glazier's roller to ensure a neat finish.

5.4 ATTACHING END PLATES

Fit end plates to all free ends, using 2x FV8-19 countersunk screws per endcap.

5.5 CLEANING

Remove any glazing stickers and clean the glass with a suitable cleaner.

Clean the balustrade members with a soft sponge and a mild household detergent mixed in warm fresh water. Remove any debris from the deck, paying attention to any iron filing swarf or rivet shanks that may cause rust spots.

IMPORTANT NOTES

- A. All assembly fasteners must be supplied by UNEX as they are specially treated & engineered to enhance their durability to meet the NZBC requirements.
- B. A balustrade should not be attached to a substrate that is not adequately designed or constructed for the service loads that will be placed upon it by the balustrade. Any issue, problem, or defect etc. must be remedied prior to balustrade installation.
- C. Any waterproofing issues are outside the scope of this guide. Advice should be sought from waterproofing specialists in such circumstances.
- D. Ensure the homeowner or purchaser is given a copy of the Care & Maintenance instructions.

INSTALLATION GUIDE FOR PANORAMA STYLE BALUSTRADES

APPLICATION

This Installation Guide covers the general fabrication of the 'Panorama AZS3®' style Balustrade.

This Guide is intended only to cover details applicable to a common and straightforward deck configuration. For any other situation, or for details not covered below, contact UNEX.

1. BALUSTRADE DESIGN

This section covers the measuring and design of the balustrade.

1.1 SITE MEASURE

Refer to "Site Measuring - General Guide" pages 129-130 for a guide of appropriate measurements that will need to be taken from the site.

1.2 BALUSTRADE SPECIFICATIONS

Ensure that adequate information and instructions have been received from customer to ensure the balustrade is designed to NZBC requirements. Such details could include: fixing methods, design wind speeds, building class designations, barrier heights, maximum opening widths, etc.

1.3. GLASS TYPE, GLASS THICKNESS, AND CLAMP ASSEMBLY CENTRES

From the relevant Style Specification, determine the appropriate glass type and thickness and the maximum clamp assembly centres.

From the relevant Fixing Specification determine the fixing type and quantity of substrate fasteners. The fixing positions are determined by the Style Specification. Any variation in the balustrade height caused by deck falls must be considered for this step. Interpolate between values on the specification tables where necessary.

NB: Styles with top rails need to be securely attached to walls or a post at free ends.

1.4 OVERALL CENTRELINE DIMENSIONS

The Overall Centreline (OCL) is the measurement of all balustrade runs in a continuous line, measured along the glass centreline (ζ) to each mitre, and to the end of each run. (See Fig. 2)

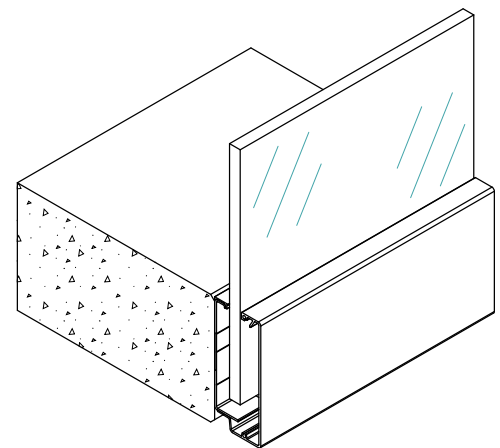
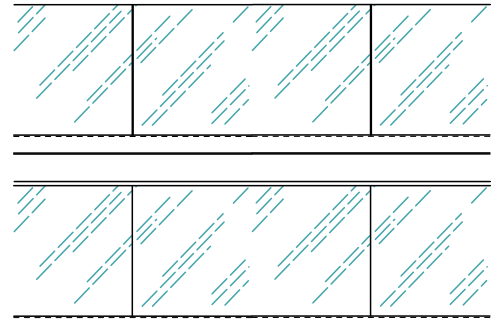

FIG. 1

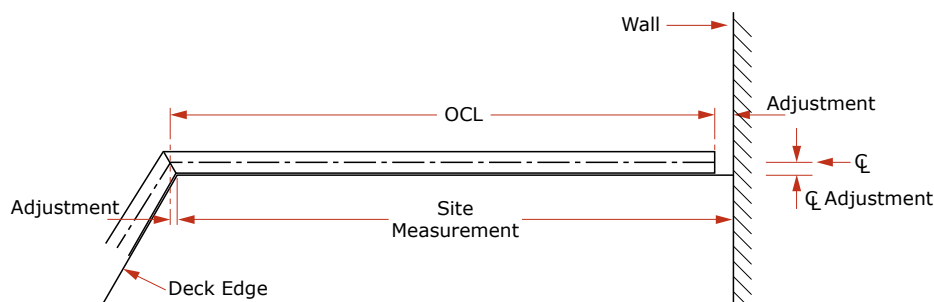

FIG. 2

(continued on following Page)

INSTALLATION GUIDE FOR PANORAMA STYLE BALUSTRADES (CONT'D)

From the site measurements, determine the OCL of the balustrade, the balustrade centreline position and any length adjustments necessary due to corners in the deck. (See Fig. 1)
Also take into account any clearances needed where the balustrade meets a wall face, and top rail ends that require secure attachment to wall or posts.

NB – the distance from the backside of the ABS150-13R alignment channel to the centreline of the glass is 34mm as shown on the Vertical Dimensions tables, excluding any additional packing.

1.5 VERTICAL DIMENSIONS

Calculate the balustrade heights and channel lengths to ensure the balustrade will meet all NZBC requirements, taking into account any deck falls and changes in deck levels.

The relevant Vertical Dimensions page will provide some useful formulae to calculate this data.

1.6 MATERIAL REQUIREMENTS

Optimise the various member types into available purchasing lengths, taking into account the additional lengths needed for mitre points, saw cuts and saw clamps etc. Any joins in the Top Outer Rail should not coincide with a join in the Top Inner Rail (if applicable).

Produce a Summary of materials required and order from UNEX.

2. FABRICATION

This section covers the cutting of the members to the required length, and the drilling of holes required. Ensure staff is provided with tools and machinery that are safe, and that they are given full instructions in how to use them. To prevent corrosion, ensure all tools/drivers/screwdriver tips are suitable for stainless steel and only used on stainless steel.

2.1 CUTTING TO LENGTH

Cut all members to their required length, as calculated in sections 1.4-1.6. Ensure all mitres are cut at the correct angle and orientation. Careful positioning of cuts is required on the ABS150-13R back alignment channel to coincide with pre-drilled hole positions.

Remove all burrs of aluminium with a light file.

2.2 DRAINAGE HOLES

Ensure drainage holes are provided, which are pre-drilled on ABM-13R (Refer to Durability on page 193)

2.3 RETAINING GASKETS

Install the correct sized retaining gasket as per the table on page 30, according to glass thickness, to the alignment channel ABS150-13R prior to installation. The gasket are colour coded for identification.

3. INSTALLATION

This section covers the Installation of the balustrade extrusions and components. Prior to commencing, ensure the Builder has completed all work necessary to support the balustrade. For timber decks, satisfactory performance of the balustrade will only be obtained if the decking is adequately seasoned and stable.

3.1 PREPARATION

For all substrate types, ensure the deck face where the balustrade is being mounted is straight and vertical. Note, installing the balustrade over tiles is not recommended as it may cause cracking of the tiles.

3.2 ABS150-13R ALIGNMENT CHANNEL PLACEMENT

Using a string line, ensure the ABS150-13R is aligned perfectly straight and plumb, both the vertical and horizontal planes. If this is not the case, pack it straight behind the ABS with solid and durable packers.

Position the base alignment channel ABS150-13R on deck so that fixings will be in their correct position in relation to the substrate.

(continued on following Page)

INSTALLATION GUIDE FOR PANORAMA STYLE BALUSTRADES (CONT'D)

Attach the ABS150-13R extrusion to the face of the deck in the correct height and location, taking care with regards to deck levels, the balustrade height and fixing locations. Attachment at this stage can be done using either a temporary fastener, or by fixing of an AGS-00-020X clamp assembly in position.

3.3 AGS CLAMP POSITIONS

Position the AGS-00-020X clamps in accordance with the maximum centres determined in step 1.3. If this does not match the pre-drilled holes on the ABS150-13R back alignment channel extrusion then mark and drill the extrusion at the exact position of each AGS-00-020X glazing clamp set, in accordance with the specified maximum centres. The clamping assembly centre should be positioned 200mm off the end of each glass pane and intermediate sets spaced between without exceeding the specified centres. It is recommended that glass joints do not occur within a clamp, and is mandatory for SentryGlas infill panels.

3.4 SUBSTRATE FASTENERS

It is essential that the channel is fastened in accordance with the Fixing Specification selected. All fixings should be Stainless Steel 316 Class 70 or greater.

For concrete decks, install the fixing studs using Epcon C6 Plus epoxy anchoring systems as per Page 167 of the Fabricator's Manual and insert an EPDM or neobonded washer between the aluminium channel and the stainless-steel washer of the substrate fastener.

For timber decks, fixings within the channel must be either coach screws or threaded studs right through the joists with stainless steel nyloc nuts and washers beneath. Fixings shall be central on the supporting joists which shall not be less than 45mm thick. Fit 50mm square washers under all bolt heads or nuts bearing on timber, unless otherwise specified by UNEX.

3.7 FINAL FIXING

Seal fastener holes, as necessary. Tighten all fasteners firmly, but not over-tightened.

3.8 PLUMB CHECK

Install a 'temporary panel' to the first and last clamps on each run and use a level to ensure the clamps are exactly plumb. Run a string line between the top edges of the 'temporary panels' at each end. Using a third 'temporary panel' work along the run through each of the clamps, plumbing each one to align the top edge of the third 'temporary panel' to the string line. Recheck for plumb, then remove the 'temporary panels'.

4. GLAZING

This section covers the measuring and installation of the glass panes. Ensure the correct thickness of toughened glass is used with the clamps. All glass must be toughened in accordance with AS/NZ 2208. Visible edges shall be Flat Polished.

4.1 GLASS SIZING AND ORDERING

Calculate and order the glass to the correct sizing and consider position of the safety stamp as default location may not be visible. For styles with no Top rail SentryGlas panes are the ONLY panes tested to support no top rail and are not to be shorter than 1.2m wide. Consideration should be given as to the size and weight of the panes and how they will be lifted into place.

4.2 GLASS JOINTS

Joints between adjacent glass panes may either have a 6mm gap and be silicone filled or have a clear gap between the panes of 12mm minimum to 95mm maximum.

On corners, the glass may be either 'square cut and overlapped', or 'mitred' with a small 6mm gap and silicone filled.

It is essential with the 'Panorama' (AZS3) style that joints are silicone filled on corners, so as to prevent the top edges of the glass coming in contact with each other when loads are placed upon them.

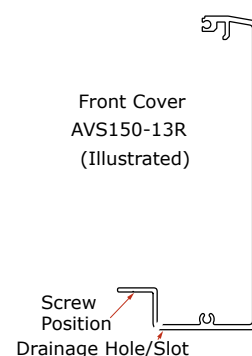

(continued on following Page)

INSTALLATION GUIDE FOR PANORAMA STYLE BALUSTRADES (CONT'D)

4.3 INSTALLING THE GLASS

Starting from one end of the balustrade, install the glass by placing it carefully down into the AGS-00-020X clamps resting on the bearing block and against the bearing plate. Tighten the lower clamping grub screws only to hold the glass, then adjust the leveling screw so the glass is truly vertical above this clamp. Then tighten the top clamping grub screws taking care not to over tighten.

Recheck to see that the glass is vertical, aligned at all joints and that all clamping sets for each pane are perfectly in line. If further adjustment is required, loosen the top grub screws, adjust leveling screw and retighten. Continue process along the balustrade, working along from one end.

5. FINISHING

This section covers the finishing touches of the aluminium balustrade.

5.1 INSTALLING THE AVS150-13 FRONT COVER

Install the AVS150-13 front cover by lowering it down vertically, hooking the top edge over the bearing plate at the front top of the AGS-00-020X clamps, then swing it into position underneath the ABS150-13R backing alignment channel so as the front face is vertical. Use the AVIS-02 jointer at joints in the cover. Attach cover in position with FTH10-19 self-drilling screws at 1.0m centres (See Fig. 2). Position screws between clamp units.

5.2 RAIL ATTACHMENT

Top rails protect monolithic glass against damage. Attach an SBC (SBG when using an ARN or VRT Top Rail) setting block to the top of the rail glazing cavity at 500 mm centres. Run an even bead of silicone continuously between them. One side of the rail should then be retained and the other side wedged, refer to Chapter 1 page 30 for gaskets and wedges. Special care shall be taken with wide top rails such as ART to obtain maximum firmness. Where the top rail comprises an inner and outer member, rivet the rails together with (FS4-4) rivets at 1000 mm centres.

Side rails are attached using LBWG (LRWG when using LRR rail) to provide a loading bearing, and continuous rail interlinking panes of glass. These brackets need to be inset 150mm from the glass pane edge on both ends for each pane and the top are required to be at the minimum barrier height according to NZBC F4/AS1.

When using ARN Top Rail, jointers and gussets should be made from the MANG extrusion, refer to page 28 for standard jointers. Also, at jointers and gussets, glass must be protected with some thin adhesive tape over the top edge and down 10mm on each side. Use adhesive to secure in place. All other Top Rail mitres and joints should be securely held together using a DNS gusset or jointer.

5.3 INSTALLING THE WEDGE

Install the correct inside wedge between top of cover plate and glass as follows:

- 12mm glass SWE35 (Wedge installed deck side)
- 13.5mm glass SWE30 (Wedge installed deck side)
- 14.28mm glass SWE25 (Wedge installed deck side)
- 15mm glass SWE25 (Wedge installed deck side)
- 16.28mm glass SWE20 (Wedge installed deck side)

Cut the SWE^{XX} glazing wedge, leaving slightly over length. Ensure the fins of glazing gaskets are inserted towards the face of the glass. Compress gaskets lengthwise during insertion. Use a glazier's roller to ensure a neat finish.

5.4 ATTACHING END PLATES

Fit end plates to all free ends, using 2x FV8-19 countersunk screws per endcap.

(continued on following Page)

Specifications subject to change without notice

INSTALLATION GUIDE FOR PANORAMA STYLE BALUSTRADES (CONT'D)

5.5 CLEANING

Remove any glazing stickers and clean the glass with a suitable cleaner.

Clean the balustrade members with a soft sponge and a mild household detergent mixed in warm fresh water. Remove any debris from the deck, paying particular attention to any iron filing swarf or rivet shanks that may cause rust spots.

IMPORTANT NOTES

- A. All assembly fasteners must be supplied by UNEX as they are specially treated to enhance their durability to meet the NZBC requirements.
- B. A balustrade should not be attached to a substrate that is not adequately designed or constructed for the service loads that will be placed upon it by the balustrade. Any issue, problem, or defect etc must be remedied prior to balustrade installation.
- C. Any waterproofing issues are outside the scope of this guide. Advice should be sought from waterproofing specialists in such circumstances.
- D. Ensure the homeowner or purchaser is given a copy of the Care & Maintenance instructions.

ARENA-POINTS INSTALLATION GUIDE

This guide is intended only to cover details applicable to a common and straightforward deck configuration. For any other situation, or for details not covered below, contact UNEX.

1. MEASUREMENTS

Accurately site measure and record the outside edge of the structure to which the Arena-Points balustrade is being attached, the distance down to the fixing points (in accordance with the Style and Fixing Specifications), and any deck slopes.

2. GLASS SIZING AND ORDERING

Calculate the glass sizes and hole positions in accordance with the measurements and the Style and Fixing Specifications. For deck configurations with corners, an adjustment will need to be made to allow for the space and gasket thickness (Arena-Points AOA050D... and AOS050D... series this is approx 32mm). See FIG. 1.

Ensure the finished height of the balustrade meets the minimum height requirement of the NZ Building Code.

Glass thickness shall be as specified in the Style Specification, and with a minimum of Flat Polished edge preparation on all visible edges. Consideration should be given as to the size and the weight of the panes and how they will be lifted into place on site.

Joints in the glass may have a 6mm gap and be silicone filled, or have a clear gap between the panes of 20mm minimum to 95mm maximum.

On corners, the glass may be either 'square cut and overlapped', or 'mitred' with a small 6mm gap and silicone filled.

It is important that the joints are silicone filled on corners, so as to prevent the top edges of the glass coming in contact with each other when loads are placed upon them.

The recommended hole size for the Arena-Points is 26mm. See FIG. 2.

NB: Styles with top rails need to be securely attached to walls or a post at free ends.

3. INSTALL SPACERS

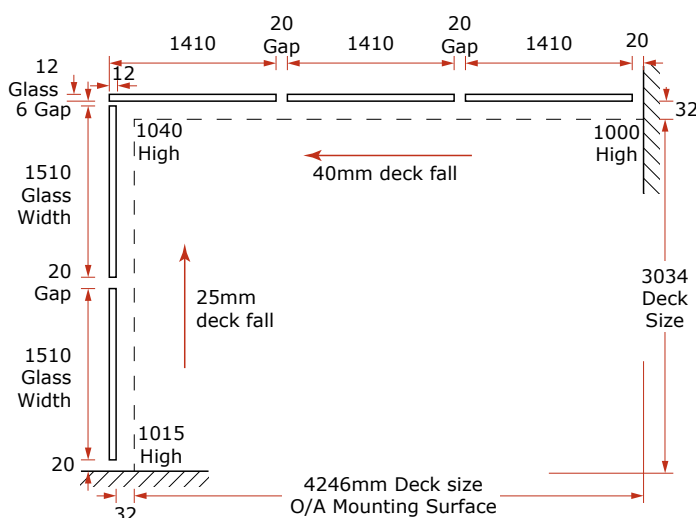
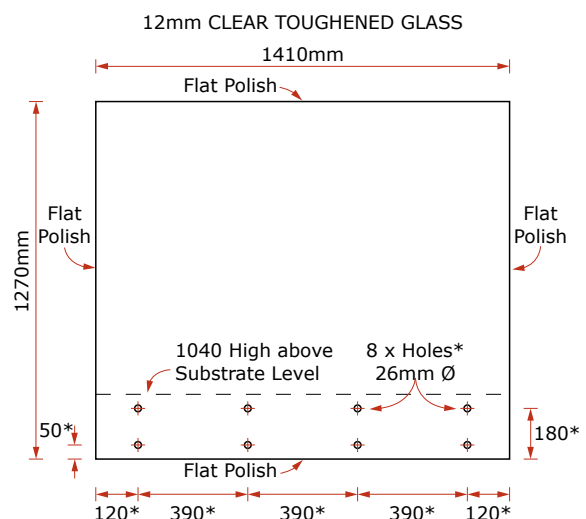

FIG. 1 DECK DIMENSIONS & GLASS PANE WIDTHS



* Example only.
All dimensions to be in accordance with specifications.

FIG. 2 EXAMPLE OF GLASS SPECIFICATION

(continued on following Page)

ARENA-POINTS INSTALLATION GUIDE - (CONT'D)

UNEX recommends using templates on material such as 3mm MDF board, core flute sheets, or similar. Using the actual glass panes, mark on the template the hole positions, centre points, substrate level, and any other relevant positions. On site, install the fasteners to manufacturer's instructions using the templates (additional information available from UNEX on some substrate fastener installations.) Install the spacers and gaskets, covering the threads with Lanolin Grease (UNEX Code TGL-05L) IMPORTANT; ensure the threaded end of the fastener will engage with the cap by a minimum of 10mm and a maximum of 12mm. Refer FIG 3.

NOTE; With some installations such as stairs and other more complex configurations, it is advisable to effectively swap the ordering of steps 2 and 3 above, i.e. installing the fasteners and using templates to manufacture the glass to suit

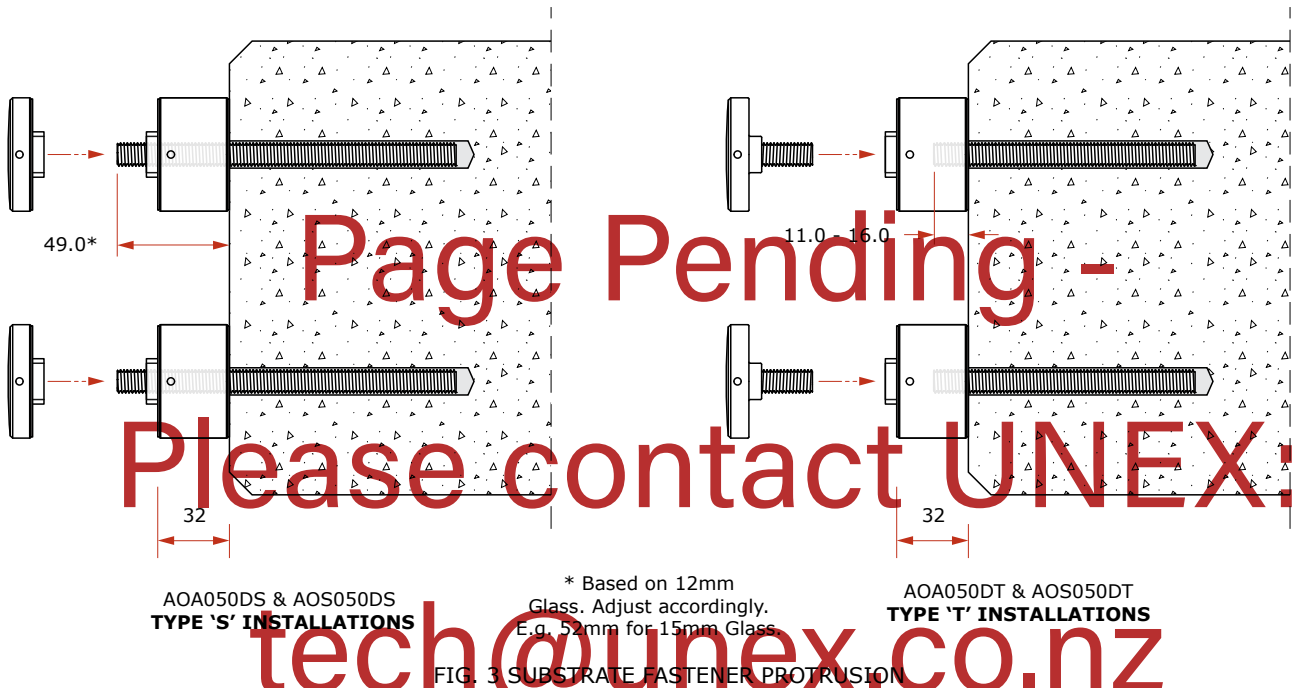

Extrusions & Components

Style Specifications

Fixing Specifications

Assembly Specifications

Fabrication & Installation

3.1 SPACER ALIGNMENT

It is important that the front surfaces of the spacers are aligned so they lie in the same vertical plane, and the glass is not stressed when no load is placed upon it. This can be achieved with the use of a straight edge, string line, and a spirit level. With fastener installations that can withstand both tensile and compression loads, it may be possible to achieve a small adjustment to the alignment with the glass in place, using a TOA adjuster tool. For all other situations, use solid and durable spacers with a Ø50mm to achieve this result.

4. INSTALL GLASS AND CAPS

Position glass in place, and attach the caps and gaskets and lock in position using the appropriate tools. With Aluminium Arena-Points ensure threads are coated with Lanolin Grease (UNEX Code TGL-05L series).

Recheck to ensure all balustrade height criteria are fulfilled, and that the glass is vertical.

Clean the glass, remove stickers, and silicone any joints (if applicable)

(continued on following Page)

ARENA-POINTS INSTALLATION GUIDE - (CONT'D)

5. INSTALL TOP RAILS

5.1 RAIL ATTACHMENT

Top rails protect monolithic glass against damage. Attach an SBC (SBG when using an ARN or VRT Top Rail) setting block to the top of the rail glazing cavity at 500 mm centres. Run an even bead of silicone continuously between them. One side of the rail should then be retained and the other side wedged, refer to Chapter 1 page 30 for gaskets and wedges. Special care shall be taken with wide top rails such as ART to obtain maximum firmness. Where the top rail comprises an inner and outer member, rivet the rails together with (FS4-4) rivets at 1000 mm centres.

Side rails are attached using LBWG (LRWG when using LRR rail) to provide a loading bearing, and continuous rail interlinking panes of glass. These brackets need to be inset 150mm from the glass pane edge on both ends for each pane and the top are required to be at the minimum barrier height according to NZBC F4/AS1.

When using ARN Top Rail, jointers and gussets should be made from the MANG extrusion, refer to page 28 for standard jointers. Also, at jointers and gussets, glass must be protected with some thin adhesive tape over the top edge and down 10mm on each side. Use adhesive to secure in place. All other Top Rail mitres and joints should be securely held together using a DNS gusset or jointer.

5.2 CLEANING

Remove any glazing stickers and clean the glass with a suitable cleaner.

Clean the balustrade members with a soft sponge and a mild household detergent mixed in warm fresh water. Remove any debris from the deck, paying particular attention to any iron filing swarf or rivet shanks that may cause rust spots.

IMPORTANT NOTES

- A. A balustrade should not be attached to a substrate that is not adequately designed or constructed for the service loads that will be placed upon it by the balustrade. Any issue, problem or defect etc must be remedied prior to balustrade installation.
- B. Any waterproofing issues are outside the scope of this guide. Advice should be sought from waterproofing specialists in such circumstances.
- C. Ensure the homeowner or purchaser is given a copy of the Care & Maintenance instructions.

INSTALLATION GUIDE FOR GLASSTRUT STYLE BALUSTRADES

APPLICATION

This guide is intended only to cover details applicable to a common and straightforward deck configuration. For any other situation, or for details not covered below, contact UNEX.

1. BALUSTRADE DESIGN

This section covers the measuring and design of the balustrade.

1.1 SITE MEASURE

Refer to "Site Measuring - General Guide" pages 129-130 for a guide of appropriate measurements that will need to be taken from the site.

1.2 BALUSTRADE SPECIFICATIONS

Ensure that adequate information and instructions have been received from customer to ensure the balustrade is designed to NZBC requirements. Such details could include; fixing methods, design wind speeds, building class designations, barrier heights, maximum opening widths, etc.

1.3 GLASS TYPE, GLASS THICKNESS, AND CLAMP ASSEMBLY CENTRES

From the relevant Style Specification, determine the appropriate glass type, thickness, and the maximum clamp assembly centres.

From the relevant Fixing Specification determine the fixing centres type and quantity of substrate fasteners. The fixing positions are determined by the Fixing Specification. Any variation in the balustrade height caused by deck falls must be considered for this step. Interpolate between values on the specification tables where necessary.

NB: Styles with top rails need to be securely attached to walls or a post at free ends.

1.4 OVERALL CENTRELINE DIMENSIONS

The Overall Centreline (OCL) is the measurement of all balustrade runs in a continuous line, measured along the glass centreline (ζ) to each mitre, and to the end of each run (see Fig. 1) for top fix and (see Fig. 2) for side fix.

From the site measurements, determine the OCL of the balustrade, the balustrade centre-line position and any length adjustments necessary due to corners in the deck. Also take into account any clearances needed where the balustrade meets a wall face, and top rail ends that require secure attachments to wall or posts.

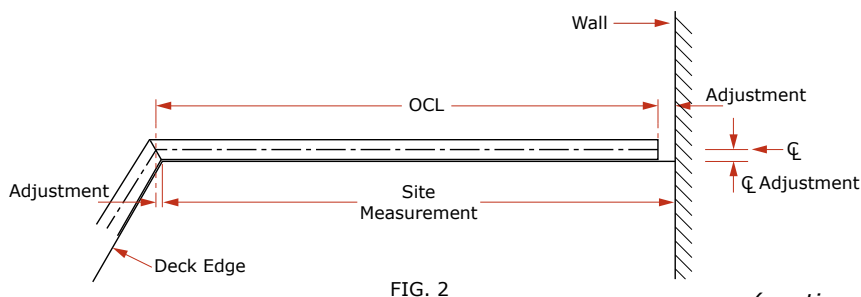
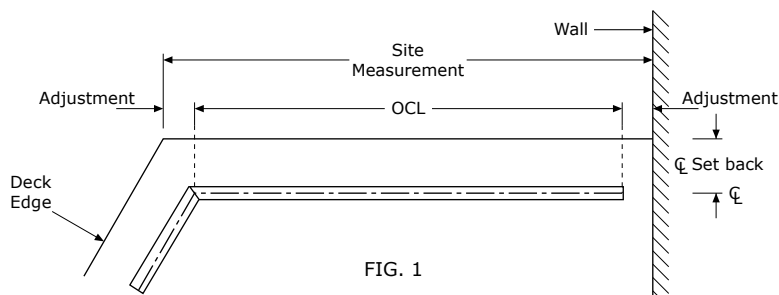

(continued on following Page)

INSTALLATION GUIDE FOR GLASSTRUT STYLE BALUSTRADES - (CONT'D)

1.5 VERTICAL DIMENSIONS

Calculate the balustrade heights and channel lengths to ensure the balustrade will meet all NZBC requirements, taking into account any deck falls and changes in deck levels.

The relevant Vertical Dimensions page will provide some useful formulae to calculate this data.

1.6 MATERIAL REQUIREMENTS

Optimise the various top rails types into available purchasing lengths, taking into account the additional lengths needed for mitre points, saw cuts and saw clamps etc. Any joins in the Top Outer Rail should not coincide with a join in the Top Inner Rail (if applicable). Determine number of mini posts required.

Generate a summary of materials required and order from UNEX Systems.

2. FABRICATION

This section covers the cutting of the members to the required length, and the drilling of holes required. Ensure staff are provided with tools and machinery required, and have full instructions on how to use them. To prevent corrosion, ensure all tools/drivers/screwdriver tips are suitable for stainless steel and only used on stainless steel.

2.1 CUTTING TO LENGTH

Cut all top rails to their required length, as calculated in sections 1.4-1.6. Ensure all mitres are cut at the correct angle and orientation. Remove all burrs with a light file.

3. INSTALLATION

This section covers the Installation of the balustrade extrusions and components. Prior to commencing, ensure the Builder has completed all work necessary to support the balustrade. For timber decks, satisfactory performance of the balustrade will only be obtained if the decking is adequately seasoned and stable.

3.1 PREPARATIONS

For all substrate types, ensure the deck where the balustrade is being mounted is straight and level. Installing the aluminium channels over tiles is not recommended as it may cause cracking of the tiles.

3.2 MINI POST PLACEMENT

Top Fixed: Position the mini posts on deck so that fixings will be in their correct position.

Attach the mini posts to the FFL of the deck at the correct location. Attachment at this stage can be done using a temporary fastener. Take particular care to ensure precise alignment of the mini posts at all in-line joints.

Side Fixed: Using a string line, ensure the mini post is aligned perfectly straight and plumb, both the vertical and horizontal planes. If this is not the case, pack it straight with solid and durable packers.

Position the mini post on deck so that fixings will be in their correct position in relation to the substrate.

Attach the mini post to the face of the deck in the correct height and location, taking care with regards to deck levels, the balustrade height and fixing locations. Attachment at this stage can be done using a temporary fastener.

3.3 MINI POST POSITIONS

Position the mini posts in accordance with the maximum centres determined in chapter 2 according to the specified maximum centres. The clamping centres should be positioned 150mm MIN – 300mm MAX off the end of glass panel, and intermediate sets spaced between without exceeding the specified centres.

3.4 FIXING HOLES

As per step 1.3, refer to the appropriate Fixing Specification for the fixing type & quantity of fasteners. Care should be taken to ensure that the heads of the substrate fixings do not interfere with clamp covers.

(continued on following Page)

INSTALLATION GUIDE FOR GLASSTRUT STYLE BALUSTRADES - (CONT'D)

3.5 SUBSTRATE FASTENERS

It is essential that the mini post is fastened in accordance with the Fixing Specification selected. All fixings should be Stainless Steel 316 Class 70 or greater.

For concrete decks, install fixing studs using Hilti Hit-HY 200- RV3 Epoxy anchoring systems as per fixing specification of the Fabricator's Manual.

For side fixing to timber decks, fixings must be coachscrews, or bolts right through the joists with stainless steel nyloc nuts and washers beneath. Fit 50mm square washers under all bolt heads or nuts bearing on timber, unless otherwise specified by UNEX.

3.6 FINAL FIXING

Seal fastener holes, as necessary. Tighten all fasteners firmly, but not over-tightened.

3.7 PLUMB CHECK

Install a 'temporary panel' to the first and last clamps on each run and use a level to ensure the clamps are exactly plumbed. Run a string line between the top edges of the 'temporary panels' at each end. Using a third 'temporary panel' work along the run through each of the clamps, plumbing each one to align the top edge of the third 'temporary panel' to the string line. Recheck for plumb, then remove the 'temporary panels'.

4. GLAZING

This section covers the measuring and installation of the glass panes. Ensure the correct thickness of toughened glass is used. All glass must be toughened in accordance with AS/NZ 2208. Visible edges shall be flat polished.

4.1 GLASS SIZING AND ORDERING

Calculate and order the glass to the correct sizing, and consider position of safety stamp as default location may not be visible. For styles with no Top rail SentryGlas panes are the ONLY panes tested to support no top rail and are not to be shorter than 1.2m wide. Consideration should be given as to the size and weight of the panes and how they will be lifted into place on site.

4.2 GLASS JOINTS

Joints between adjacent glass panes may either have a 6mm gap and be silicone filled or have a clear gap between the panes of 10mm minimum to 95mm maximum (Note: A minimum of 12mm is preferred to prevent the risk of injury to children's fingers).

On corners, the glass may be either 'square cut and overlapped', with a small 6mm gap and silicone filled.

4.3 INSTALLING THE GLASS

Starting at one end, install the glass by placing it carefully into the mini post clamps resting on the polymer clamp. Tighten the lower clamping grub screws only to hold the glass. Then tighten the top clamping grub screws taking care not to over tighten.

Recheck to see that the glass is vertical, aligned at all joints and that all mini posts for each pane are perfectly in line. Continue process along the balustrade, working along from one end.

5. FINISHING

This section covers the finishing touches of the aluminium balustrade.

5.1 RAIL ATTACHMENT

Install the inside AVM-13 covers by lowering it down vertically, and clipping the lower end onto the ABM-13R base alignment channel, and the top to the bearing block/plate within the clamps.

(continued on following Page)

INSTALLATION GUIDE FOR GLASSTRUT STYLE BALUSTRADES - (CONT'D)

5.2 RAIL ATTACHMENT

Top rails provide protection to monolithic glass against damage. Attach a setting block or gasket (refer to Vertical Dimensions or Assembly Specifications) to the top of the rail glazing cavity at 500 mm centres for setting blocks. Where setting blocks are used but without glazing gaskets, structural silicone shall be generously applied inside the top rail on both sides of the glass, ensure silicone has a neat bead by finishing with finishing tool to remove all excess silicone

For VRR top rails, one side of the rail should be retained and the other side wedged (refer to Chapter 1 for gaskets and wedges).

Where the top rail consists of an inner and outer member, rivet the two together using FS4-4 rivets at 1000 mm centres.

For rails with a single internal gasket, apply structural silicone between the rail and gasket. When installing the rail, also apply structural silicone to the top edge of the glass.

5.3 INSTALLING THE WEDGE

Use 12 mm glass wedge, consistent with other frameless glass specifications.

5.5 CLEANING

Remove any glazing stickers and clean the glass with a suitable cleaner.

Clean the balustrade members with a soft sponge and a mild household detergent mixed in warm fresh water. Remove any debris from the deck, paying attention to any iron filing swarf or rivet shanks that may cause rust spots.

IMPORTANT NOTES

- A. All assembly fasteners must be supplied by UNEX as they are specially treated & engineered to enhance their durability to meet the NZBC requirements.
- B. A balustrade should not be attached to a substrate that is not adequately designed or constructed for the service loads that will be placed upon it by the balustrade. Any issue, problem, or defect etc. must be remedied prior to balustrade installation.
- C. Any waterproofing issues are outside the scope of this guide. Advice should be sought from waterproofing specialists in such circumstances.
- D. Ensure the homeowner or purchaser is given a copy of the Care & Maintenance instructions.

UNEX LOADING CLASSIFICATION

Below is an extract from AS/NZS 1170:2011.1:2002, a standard which is cited in the NZBC. This table gives the minimum imposed actions on barriers for various occupancy types. To the right hand side of this table are the applicable UNEX Loading Classifications (ULC) which are stated in the specifications contained in this catalogue.

AS/NZS 1170.1:2002 TABLE 3.3 MINIMUM IMPOSED ACTIONS FOR BARRIERS							ULC (UNEX Loading Classifi- cations)
Type of occupancy for part of the building or structure	Specific Uses	Top Edge			Infill		
		Horizontal kN/m	Vertical kN/m	Inwards, Outwards, Downwards kN	Horizontal kPa	Any Direction kN	
A Domestic and residential activities	All areas within or serving exclusively one dwelling including stairs, landings, etc., but excluding external balconies and edges of roofs (see C3)	0.35	0.35	0.6	0.5	0.25	→ N03R
	Other residential (see C3)	0.75	0.75	0.6	1.0	0.5	→ N07R
B, E Offices and work areas not included elsewhere including storage areas	Light access stairs and gangways not more than 600mm wide	0.22	0.22	0.6	N/A	N/A	→ N02
	Fixed platforms, walkways, stairways and ladders for access	0.35	0.35	0.6	N/A	N/A	→ N03C
	Areas not susceptible to overcrowding in office and institutional buildings also industrial and storage buildings	0.75	0.75	0.6	1.0	0.5	→ N07C
AREAS WHERE PEOPLE MAY CONGREGATE							
C1/C2 Areas with tables or fixed seating	Areas with fixed seating adjacent to a balustrade, restaurants, bars, etc.	1.5	0.75	0.6	1.5	1.5	→ N15
C3 Areas without obstacles for moving people and not susceptible to over-crowding	Stairs, landings, external balconies, edges of roofs, etc.	0.75	0.75	0.6	1.0	0.5	→ N07C
C5 Areas susceptible to over-crowding	Theatres, cinemas, grandstands, discotheques, bars, clubs, auditoriums, shopping malls (see also D), assembly areas, studios, etc	3.0*	0.75	0.6	1.5	1.5	→ N30 → N20⁽¹⁾
D Retail areas	All retail areas including public areas of banks/building societies (see C5 for areas where over-crowding may occur)	1.5	0.75	0.6	1.5	1.5	→ N15
F/G Vehicular	Pedestrian areas in car parks including stairs, landings, ramps, edges of internal floors, footways, edge of roofs	1.5	0.75	0.6	1.5	1.5	→ N15
	Horizontal loads imposed by vehicles	Requires site specific UNEX design					

⁽¹⁾ N20 is only applicable where 2.0kN/m horizontal top edge load is acceptable by the Building Consent Authorities.

This page is copyright to UNEX Systems (NZ) Ltd with the exception that the copyright for Table 3.3 of AS/NZS 1170.1:2002 is held by Standards New Zealand. Permission for UNEX Systems to use it has been obtained under Copyright License 000913



association of
consulting and
engineering

Building Code Clause(s) B1/VM1,F2,F4

PRODUCER STATEMENT – PS1 – DESIGN

ISSUED BY: EQSTRUC Limited
(Design Firm)

TO: Unex Architectural Barriers
(Owner/Developer)

TO BE SUPPLIED TO: All Building consent authorities within New Zealand
(Building Consent Authority)

IN RESPECT OF: This is an sample PS1,
(Description of Building Work)

AT: Any location within New Zealand within the limits of this PS1 document.
(Address)

Town/City: LOT DP SO
(Address)

We have been engaged by the owner/developer referred to above to provide:
Provide structural design and level of the Unex Panorama-style balustrade system (NZBA-D 311). Design of the supporting structure beyond the balustrade fixings is excluded and shall be by others
(Extent of Engagement)

services in respect of the requirements of Clause(s) B1 of the Building Code for:
 All or Part only (as specified in the attachment to this statement), of the proposed building work.
The design carried out by us has been prepared in accordance with:

Compliance Documents issued by the Ministry of Business, Innovation & Employment B1/VM1,F2,F4 or
(verification method/acceptable solution)

Alternative solutions as set out in the schedule
The proposed building work covered by this producer statement is described on the drawings titled:

Unex Panorama Specification stamped by EQSTRUC and numbered SK1 to SK6
together with the specification, and other documents set out in the schedule attached to this statement.

On behalf of the Design Firm and subject to Testing by supplier:
(i) Site verification of the following design assumptions
(ii) All proprietary products meeting their performance specification requirements;

I believe on reasonable grounds that a) the building, if constructed in accordance with the drawings, specifications, and other documents provided or listed in the attached schedule, will comply with the relevant provisions of the Building Code and that b), the persons who have undertaken the design have the necessary competency to do so. I also recommend the following level of construction monitoring/observation:
 CM1 CM2 CM3 CM4 CM5 (Engineering Categories)

I, Khaled Eid am: CPEng # 1006329
(Name of Design Professional)

I am a member of: Engineering New Zealand and hold the following qualifications: B.E.(Structural), MEngSt(Hons)

The Design Firm issuing this statement holds a current policy of Professional Indemnity Insurance no less than \$200,000*.
The Design Firm is a member of ACE New Zealand:

SIGNED BY: Khaled Eid (Signature) Khaled Eid
(Name of Design Professional)

ON BEHALF OF EQSTRUC Limited Date 27.03.2025
(Design Firm)

Note: This statement shall only be relied upon by the Building Consent Authority named above. Liability under this statement accrues to the Design Firm only. The total maximum amount of damages payable arising from this statement and all other statements provided to the Building Consent Authority in relation to this building work, whether in contract, tort or otherwise (including negligence), is limited to the sum of \$200,000*.
This form is to accompany Form 2 of the Building (Forms) Regulations 2004 for the application of a Building Consent.
THIS FORM AND ITS CONDITIONS ARE COPYRIGHT TO ACE NEW ZEALAND AND ENGINEERING NEW ZEALAND

BUILDING CONSENT APPLICATION DOCUMENTS

Following are the 5 recommended pages for submitting a Building Consent Application.

1. Fill out a PS1 Producer Statement page



2. The relevant Style Specification page

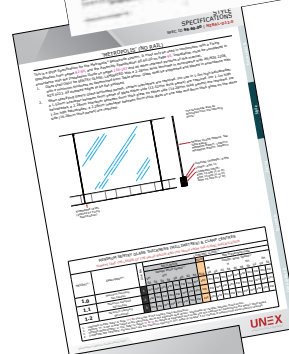

3. The relevant Fixing Specification page

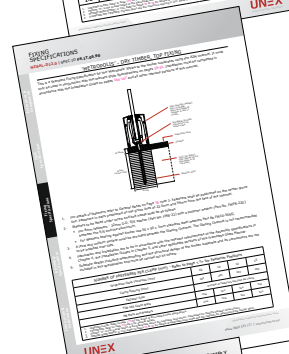

4. The relevant Assembly Specification page

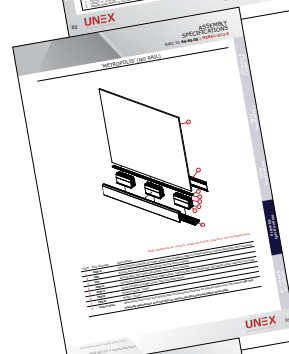

5. The Unex Loading Classifications page

